

Free from Poverty

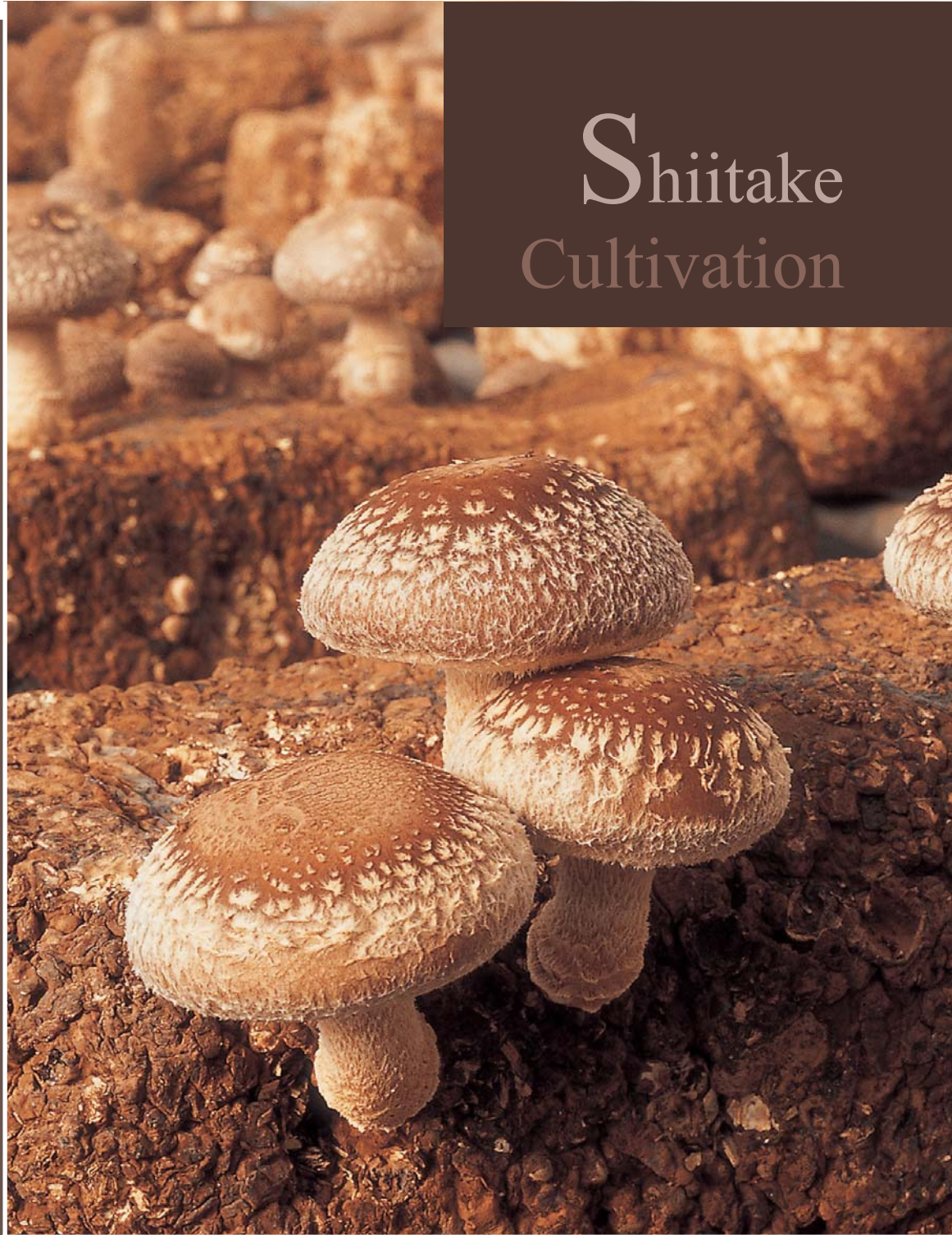
**Mushroom  
Growers'  
Handbook** **2**

**Shiitake  
Cultivation**

Free from Poverty

# Mushroom Growers' Handbook **2**

## Shiitake Cultivation



---

Copyright © 2005 by MushWorld

All rights reserved. No part of this book may be reproduced, in any form or by any means, without prior permission in writing from the publisher.

ISSN 1739-1377

Published by **MushWorld**

Haeng-oon Bldg. 150-5 Pyungchang-dong, Jongno-gu, SEOUL 110-846, KOREA

Tel. +82-2-396-1507

Fax. +82-2-396-1547

<http://www.MushWorld.com>

[info@MushWorld.com](mailto:info@MushWorld.com)

---

Distributed mainly to developing countries for free

Printed in Republic of Korea

## PREFACE

As a non-profit organization, MushWorld has devoted itself to distributing abundant, valuable information on mushroom science and cultivation via its website, [www.MushWorld.com](http://www.MushWorld.com), for free since established in 1998. Though the access to MushWorld is free and unlimited, Internet is not readily available for people in developing countries, who sincerely need information sources for mushroom growing.

The **Mushroom Growers' Handbook** series published and distributed for free by MushWorld is aimed at providing those people with greater access to information on mushroom cultivation. The first handbook was published in March, 2004, on the subject of oyster mushroom cultivation and has been distributed to developing countries free of charge through their embassies and NGOs. All the papers included in the first handbook are also being provided on the MushWorld website. This handbook joined in disseminating the effectiveness of mushroom growing as a means of poverty alleviation and in providing practical guides to oyster mushroom cultivation in less developed countries. Since distribution of the handbook, many letters of appreciation and encouragement have been received from those interested in poverty alleviation by mushroom farming or mushroom growing project.

Following the successful publication of the 1st handbook, MushWorld worked on its second handbook, which is about shiitake cultivation, by reviewing various publications on shiitake, contacting mushroom growers and scientists in every corner of the world, and visiting exemplary shiitake growing bases in developing countries.

**Mushroom Growers' Handbook 2: Shiitake Cultivation** covers various aspects of shiitake cultivation with emphasis on applicable technology, especially in developing countries. It consists of two parts and ten chapters.

### **Part I deals with all the aspects of shiitake cultivation.**

**Chapter 1** is an introduction to shiitake and its cultivation. It presents interesting aspects of shiitake cultivation including its cultivation history, various kinds of growing practices, world production & consumption, nutritional & medicinal values, and illustrated guides to shiitake cultivation.

**Chapter 2** is about spawn and strain, one of the most important factors affecting mushroom growing. In this chapter, shiitake spawn preparation is provided with vivid images, shiitake spawn improvement for alternative substrates is discussed, and finally, cryogenic preservation method of shiitake spawn stocks is described.

**Chapter 3** reviews shiitake cultivation on log, a traditional method. Every detail of log cultivation is elaborated with solid scientific data and 2 examples in Brazil and Nepal.

**Chapter 4** is about shiitake bag cultivation, which is widely practiced. This chapter begins with a technical investigation on principles of shiitake cultivation on sawdust. Following are several examples of shiitake growing on different alternative substrates. The subsequent examples of shiitake growing in Thailand and China illustrate various practices of bag cultivation adapted to each region. Finally, farm diary of shiitake bag cultivation encourages growers to do various trials to find cultivation methods best fit for their environmental and market conditions.

**Chapter 5** contains how to manage pest and disease of shiitake. Pathogens, symptoms and control measures of different pests and diseases are well summarized for log and bag cultivation respectively. Abnormal growth is also described with informative supporting images.

**Chapter 6** illustrates shiitake growing houses in Thailand and how to regulate environmental parameters. It is followed by a detailed description of Korean shiitake growing houses, which makes full use of environmental conditions.

**Chapter 7** the last chapter of the Part I, covers post-harvest management. Various ways of recycling of spent shiitake substrate and processing harvested shiitake are illustrated. Suggestions are provided for farm management and marketing.

### **Part II illustrates mushroom growing for better life in the world.**

**Chapter 8** is about cultivation of various mushrooms for a living. It includes *Coprinus* mushroom in Thailand, *Agaricus blazei* in Brazil, and oyster mushroom in Egypt.

**Chapter 9** illustrates how mushroom growing projects for poverty alleviation were planned and implemented in Nepal and Colombia, to provide possible project planners and managers with a guide to mushroom growing project.

**Chapter 10** provides in-depth researches on the potential of mushroom industry in two Asian countries: Lao PDR and Vietnam.

**Appendix** provides invaluable information sources not to be missed.

**Resource directory** offers contact information of spawn providers and mushroom consultants and lists of books, periodicals, papers, and online publications regarding shiitake.

**MushWorld's Profile** presents MushWorld's mission, activities and milestones in detail, along with its network throughout the world.

**Index** will allow you to locate the pages that address a given topic throughout this handbook.

### Acknowledgement

As it was for the first handbook, the second handbook came into being thanks to those devoted scientists and growers from various countries as well as MushWorld staff members. Mr. Rick Gush again volunteered to devote his valuable time to copy-editing 370 pages of manuscripts. We are always impressed by his enthusiasm and hard work. MushWorld takes this opportunity to express our special thanks to Mr. Rick Gush for his great job.

MushWorld also wants to acknowledge that Prof. Kwon-Sang Yoon and Dr. Won-Chull Bak read all the papers with much care and provided elaborate scientific supervision for the entire handbook. As accomplished scholars in mycology and mushroom science, they contributed a lot to the completion of the handbook. Sally Feistels reviewed every manuscript and provided suggestions and feedbacks from the view point as a non-professional in this field. Her suggestion made this handbook more understandable to the readers with relatively little background knowledge on shiitake and its cultivation.

Also, we appreciate MushWorld members from Egypt, Dr. Amira Ali El-Fallal who generously contributed images of mushroom growing in Egypt. Tawat Tapingkae provided detailed review for the manuscripts on Thailand. Photo credits are also given to Furugawa and Nobuchi, and Renato May. A special thanks is made to Mi Jung Kang for her creative and devoted design work.

Primary acknowledgement must go to the many contributed authors listed below from nearly a score of countries. Being MushWorld members, they gave us valuable contributions devoted to poverty alleviation through mushroom farming, and substantial encouragement as well.

Badr, Ahmed (Egypt)	Matute, R. Gonzalez (Argentina)
Bak, Won-Chull (Korea)	Mendonça, Margarida (Brazil)
Cadorin, Anselmo (Brazil)	Moon, Seung Wan (Korea)
Chen, Alice W. (The U.S.)	Murray, Clare (The U.K.)
Cho, Song Baek (James) (Korea)	Osathaphant, Praphant (Thailand)
Choi, Chan-Kyu (Korea)	Pale, Wanchai (Thailand)
Choi, Kyung Wha (Ivy) (Korea)	Pan, Huijuan (China)
Curvetto, N.R. (Argentina)	Pejaranonda, Bavornsak (Thailand)
Delmastro, S. (Argentina)	Phan, Huy Duk (Vietnam)
Fan, Leifa (China)	Rinker, Danny L. (Canada)
Figlas, D. (Argentina)	Royse, Daniel J. (The U.S.)
Hobbs, Christopher (The U.S.)	Salmones, Dulce (Mexico)
Jaramillo, Carmenza Lopez (Colombia)	Santana, Cristiane de Castro (Brazil)
Kang, Seungwoo (Richard) (Korea)	Savoie, Jean-Michel (France)
Kasuya, Maria Catarina (Brazil)	Shen, Qing (The U.S.)
Kim, Byung Sik (Steve) (Korea)	Soccol, Carlos R. (Brazil)
Kwon, Hyunjong (Miji) (Korea)	Tapingkae, Tawat (Thailand)
Lin, Dongmei (China)	Thevasingh, Mungkorn (Thailand)
Lin, Zhanxi (China)	Tokimoto, Keisuke (Japan)
Manabe, Akihiko (Brazil)	Vanetti, Maria Cristina (Brazil)
Manandhar, Keshari L. (Nepal)	Vieira, Ademir João (Brazil)
Mata, Gerardo (Mexico)	Wu, Yingmei (China)



# TABLE OF CONTENTS

Preface

Table of Contents

Photo Gallery

## Part I. Shiitake

### Chapter 1 What is Shiitake

What is Shiitake? .....	1
Nutritional and Medicinal Values of Shiitake .....	12
Illustrated Guide to Shiitake Cultivation .....	22

### Chapter 2 Shiitake Spawn and Strain

Shiitake Spawn Preparation Chiefly with Sawdust .....	27
Improvement of Spawn for Cultivation in Alternative Substrates .....	36
Preservation of Shiitake Spawn Stocks by Cryogenic Storage .....	42

### Chapter 3 Shiitake Log Cultivation

Shiitake Log Cultivation .....	46
Shiitake Log Cultivation in Brazil .....	61
Shiitake Log Cultivation in Nepal .....	67

### Chapter 4 Shiitake Bag Cultivation

Shiitake Bag Cultivation .....	73
Shiitake Bag Cultivation in the U.S. ....	88
Alternative Substrate for Shiitake .....	91
Coffee Residues .....	92
Grass .....	96
Sunflower Seed Hulls .....	100
Wheat Straw .....	105
Shiitake Bag Cultivation in Thailand .....	110
Shiitake Bag Cultivation in China .....	121
Farm Diary for Shiitake Bag Cultivation .....	132

<b>Chapter 5</b>	<b>Pest and Disease Management of Shiitake</b>	
	Biology and Control of Pests and Diseases in Shiitake Log Cultivation .....	152
	Pest and Disease Management in Shiitake Bag Cultivation .....	162
<b>Chapter 6</b>	<b>Shiitake Growing House</b>	
	Shiitake Growing Houses in Thailand and Their Management .....	169
	Shiitake Growing Houses-Korean Cases .....	178
<b>Chapter 7</b>	<b>Shiitake Post Harvest</b>	
	Recycling Spent Shiitake Substrate .....	186
	Processing of Shiitake .....	190
	Considerations Related to Farm Management and Marketing .....	195
<b>Part II. Mushrooms for Better Life</b>		
<b>Chapter 8</b>	<b>Mushroom for a Living</b>	
	<i>Coprinus</i> Mushroom Cultivation in Thailand .....	199
	<i>Agaricus blazei</i> Cultivation for a Living in Brazil .....	208
	Small Scale Oyster Mushroom Cultivation in Egypt .....	219
<b>Chapter 9</b>	<b>Mushroom Growing Project</b>	
	Pilot Mushroom Cultivation Project in Nepal .....	223
	Mushroom Growing Project in Colombia .....	234
<b>Chapter 10</b>	<b>Regional Studies</b>	
	Mushroom Growing in Lao PDR .....	244
	Mushrooms and Cultivation of Mushrooms in Vietnam .....	260
<b>Appendix</b>		
	<b>Resource Directory</b> .....	270
	<b>MushWorld's Profile</b> .....	280

## Fruitbodies

# MUSHROOM PHOTO GALLERY



1	2
3	4
5	6

1. Young fruitbody that comes out opening the styrofoam sealing
2. Mature shiitake fruitbody grown on log
3. Fruitbodies heading for sky (showing negative geotropism)
4. Fruitbodies grown on sawdust block
5. Fruitbodies from white synthetic log on the ground
6. Shiitake gills (still inrolled) and stipe

## Shiitake Growing Facilities



MUSHROOM PHOTO GALLERY

1. Outdoor shiitake growing on log under trees and shading net
2. High cost shiitake growing house made of steel pipes, plastic sheet, shading net, watering hose & nozzles
3. Low-cost model made of bamboo, plastic sheet, rope and poles; covered with wood branches
4. High-cost model made of steel pipes, plastic sheet, shading net, bracket, etc.
5. Improved recycled heating system: used boiler, fan and ducts are assembled.
6. Improved recycled cooling system: radiator from a retired car, fan from wasted air condenser

1	2
3	4
5	6

## Substrate Preparation

# MUSHROOM PHOTO GALLERY



1	2
3	4
5	6

1. Tree felling and cutting in winter season, the tree's dormant season
2. Workers drilling inoculation holes on logs wear goggles for safety
3. Bag filling machine, shovel, gloves, plastic bags
4. Complicated filling machine (semi-automatic bagging machine)
5. Traditional steam sterilization kiln made of bricks and tarpaulin
6. Double door sterilizer made from steel panel

## Spawning (Inoculation)



1. Low-cost clean bench made of wood and transparent panel
2. Improved modern clean booth; made from sandwich panel rest after building incubation room, air filter from a retired truck, plastic sheet, tape
3. Inside a spawning booth; HEPA filter installed on the ceiling, dust-proof suit, protective mask
4. Spawning sawdust plug spawn into substrate bag (punching a hole and putting thimble spawn)
5. Spawning sawdust plug spawn into log
6. Inject the sawdust spawn into inoculation hole using spawning gun

1	2
3	4
5	6

## Cultivation

# MUSHROOM PHOTO GALLERY



1	2
3	4
5	6

1. Incubation of logs
2. Column method
3. Water injection through nozzle after removing plastic bags from browned sawdust synthetic logs
4. Synthetic logs with plastic bags removed and water retaining membrane applied
5. Carriers, can be hung on a shoulder like a seesaw, on carts for moving the bags
6. Steel frame for soaking the sawdust block after each flush; operated by hoist



1. Manual trimming and grading harvested shiitake on wooden net
2. Grading belt
3. Sun drying of harvested shiitake on wooden net
4. Modern thermal drying machine
5. Boiling pot for parboiling harvested shiitake
6. Shiitake mushrooms brined in containers

1	2
3	4
5	6

## Part I Shiitake

## Chapter 1

What is Shiitake

## WHAT IS SHIITAKE?

Alice W. Chen

Specialty Mushrooms, 1730 Penfield Rd. #41, Penfield, NY 14526, The U.S. (alicewchen@msn.com)

## Introduction to Shiitake

What are shiitake? Shiitake (*Lentinula edodes*) are the mushrooms that the Chinese affectionately named “Xiang-gu” (or “Shiang-gu”), “the fragrant mushrooms”. They are a treasured and traditional delicacy at dinner tables in China, Japan, and Korea. These favorite mushrooms from the Orient are not only delicious and nutritious food with great flavor and an enticing aroma, but they also contain a material well-known for its medicinal benefits. Lentinan ( $\beta$ -1,3 glucan with  $\beta$ -1,6 and  $\beta$ -1,3 glucopyranoside branchings), a water-soluble polysaccharide produced and extracted from shiitake, is an approved anti-cancer drug in Japan.

Native to the Far East, shiitake have been found in the wild only in such places as China, Japan and Korea until recently. Two recent findings of shiitake in natural habitats in the United States could have originated from disposed fibrous stems of fresh shiitake. Mushrooms that grow primarily in temperate climates, shiitake grow singly or in clusters in declining or dead hardwoods, in particular, Shii (*Pasania* spp.), oaks (*Quercus* spp.), and other Asian oaks and beeches (Stamets, 2000). In nature, shiitake are saprophytic<sup>1</sup> white-rot fungi that degrade woody substrates containing recalcitrant, hard to decompose, lignin components. It is due to this capacity that wood logs and sawdust are now used as substrates to cultivate shiitake.



Figure 1. Shiitake culture  
(Photo courtesy of Dr. Noel Arnold)

Fleshy gilled mushrooms, shiitake produce white spores and white mycelia (Fig. 1). How the four basidiospores<sup>2</sup> in shiitake are formed on a basidium<sup>3</sup> was described vividly through electron-scanning microscopy by Wu (2000). Shiitake usually have central stalks attached to circular-shaped mushroom caps that are light tan to dark brown and 5-25cm across. Some strains produce light-colored mushrooms, while others produce dark ones. Some shiitake have a nice flecking with velvety white hairy material on the caps. Growers are aware what kind of shiitake consumers want in their targeted markets. Consumers in upstate New York in the U.S. are familiar with the tasty light-colored shiitake produced by one of the leading specialty mushroom farms; Phillips Mushroom farms in Pennsylvania ([www.phillipsmushroomfarms.com](http://www.phillipsmushroomfarms.com)), while consumers in China, Japan, and Korea cherish flower shiitake (Figs. 2). There may be a reasonable question arises as to whether consumer preferences are actually dictated by the growers according to product availability.

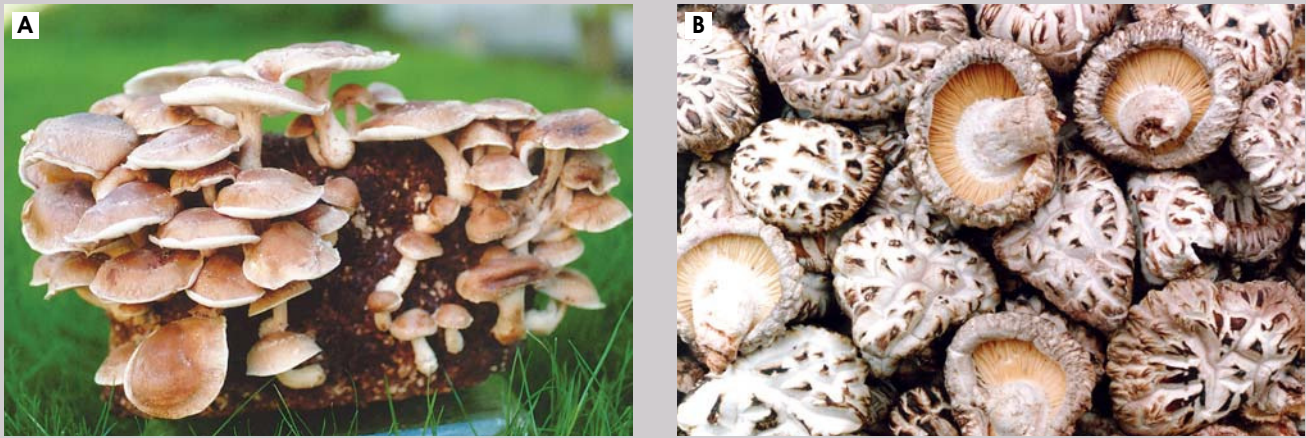
## Taxonomy

In different parts of the world, shiitake is known by different names. The name shiitake (shii-mushroom) is derived from Japanese words: “shii” meaning the hardwood of *Pasania* spp. and “take” meaning mushroom. The name shiitake is now the most popular name for this mushroom that is the most popular specialty mushroom worldwide. In the U.S. it is also known

<sup>1</sup> saprophytic: growing on dead or decaying organic matter

<sup>2</sup> basidiospore: a sexually produced spore borne on a basidium

<sup>3</sup> basidium: a small, specialized club-shaped structure bearing basidiospores

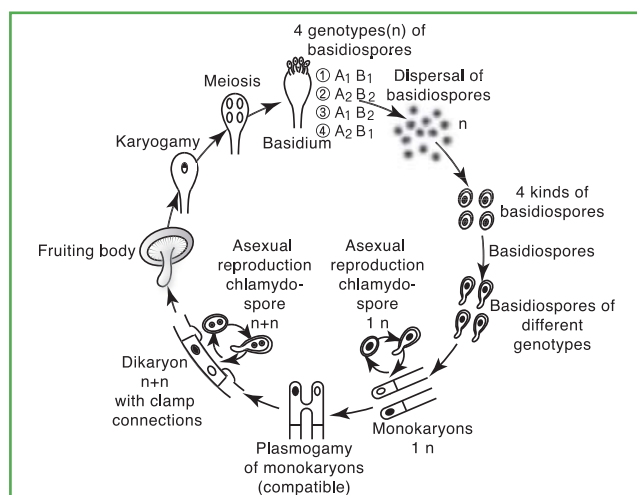


**Figure 2.** Consumer preference **A:** Light-colored shiitake **B:** Dried flower shiitake with white cracks on the cap (Jang-heung, Korea)

as the black forest mushroom. In France, it is known as lectin. In China, different forms of shiitake are known by various names such as xiang-gu, the fragrant mushroom, dong-gu, the winter mushroom, and hua-gu, the flower mushroom or variegated mushroom (Chen, 2001). This abundance of different local common names for the same species illustrates the importance of having a universal name that everyone understands. The scientific name for shiitake is *Lentinula edodes* (Berkeley) Pegler. Based on macro- and micro- morphological characteristics as well as other features including DNA analysis, *L. edodes* is classified in the genus of *Lentinula*, the family of *Tricholomataceae*, the order of *Agaricales*, and the subphylum of *Basidiomycotina*.

For a long time shiitake was known as *Lentinus edodes* (Berk.) Singer, especially among mushroom growers. In 1975, Pegler proposed this species be transferred to *Lentinula*. The rationale of the transfer was based on microscopic studies. The genus *Lentinula* is monomitic (one kind of mycelium), so the species in this genus do not contain dimittic (two kinds of) hyphae in the mushroom flesh seen in the genus of *Lentinus*. The cells are arranged in the mushroom gill trama in a parallel and descending fashion instead of having highly irregular or interwoven cells in the gill trama as in the genus of *Lentinus*. Recent DNA studies also support placement in the *Lentinula* genus. Mushroom growers, however, continued to use the old name *Lentinus edodes* until the 1980's and beyond. The name *Letinus edodes* was still used in 1989 and 1992 in two important books. It is helpful to keep in mind this historical name, *Lentinus edodes* (Berk.) Singer, when conducting literature searches or other explorations.

### Life cycle



**Figure 3.** Shiitake life cycle

The accompanying illustration of the shiitake life cycle clearly indicates how shiitake grows from dispersed basidiospores produced in the fertile gills in the underside of the mushroom cap (Fig. 3). In a favorable environment, these basidiospores, produced by sexual reproduction through meiosis, germinate into monokaryotic hyphae<sup>4</sup>. Genetically compatible mononucleate hyphae fuse through plasmogamy (hyphal fusion) to produce dikaryotic hyphae<sup>5</sup>. With genetic material from both nuclei, it is the dikaryotic hypha (hyphae: plural in number) which is capable of giving rise to the spore-bearing fruiting body known as the mushroom, the target in shiitake cultivation. The production of basidiospores by the matured mushroom completes the life cycle.

It is wise to understand the life cycle of a mushroom before attempting to grow it. A good example of effective strain development is the development in Japan by cross-breeding of the

<sup>4</sup> monokaryotic hyphae: with one nucleus in each hyphal compartment

<sup>5</sup> dikaryotic hyphae: with two genetically different nuclei in each hyphal compartment



**Figure 4.** Hokken 600, a related strain

highly desirable shiitake strain, Hogan 101 in 1990 (Fig. 4). This fast-growing strain of shiitake has a firmer flesh and produces a higher yield than other available shiitake strains.

### Three major milestones in shiitake cultivation

First discovered in China, shiitake have a fascinating history. Professors S. T. Chang and Philip G. Miles (2004), two pioneers in specialty mushrooms, described the first milestone in the history of shiitake as the first cultivator. Many centuries ago, a legendary figure known as Wu San Kang hunted and collected mushrooms for food in the wild forest of the mountainous Lung-Skyr village, in Longquan County in southwest Zhejiang Province bordering Fujian. He was an ingenious observer who figured out how to grow wild shiitake in 1100 A.D. during the Sung Dynasty (Luo, 2004). Wu San

Kang noticed that shiitake were found on fallen logs in the woods. When he cut the logs, the mushrooms grown on the logs were larger and better. However, at times to his disappointment, there were not any mushrooms despite his cuttings. One day, in a rage he beat the logs furiously. To his surprise, mushrooms sprang up profusely like flowers all over the logs after several days. This is said to be the origin of the “shocking method,” the cutting and beating practice in shiitake log cultivation. Today, 95% of the farmers in the three-county region where Wu was born (Longquan, Qingyuan and Jingning) continue the tradition of growing mainly shiitake, although today 80% use sawdust bags, while only 20% still use wood logs.

This historical place is in a region with 98% mountainous terrain. The three counties are located between 118°43' and 120°15' East longitude, and 27°00' and 28°21' North latitude. The climate is warm and humid with four distinct seasons. The average rainfall is 1,200mm and the average temperature is 17°C with an average of 300 frost-free days per year. Such information may be useful to those who are encouraging the growing of shiitake in the uncharted frontiers of poverty-stricken



**Figure 5.** Various methods of shiitake cultivation **A:** Log cultivation **B:** Cylindrical synthetic log **C:** Sawdust substrate block **D:** Sawdust slate

regions world-wide in order to alleviate hunger.

The second milestone in the history of shiitake cultivation was the application of pure-culture spawn<sup>6</sup> in growing shiitake logs by K. Kitajima in Japan in 1936 (Chang and Miles, 2004). Kitajima was an important grower who took advantage of the discovery of the pure culture technique<sup>7</sup> by using it in shiitake log production. He demonstrated how spawn can be made from a pure culture without the contamination of other microbes, and how this could be used to inoculate logs deliberately at the growers' will. The discovery of the pure culture technique was credited to Shozaburo Mimura, a Japanese mycologist, who had published earlier his findings in 1904 and 1915 (Stamets, 2000). The pure culture approach put the control of shiitake production in the hands of the growers.

The third historical milestone in shiitake cultivation was the invention of sawdust substrate cultivation. The "Mushroom Cylinder Method" was evolved and improved by Z. W. Peng in Gutien, Fujian, China in 1983 (Ting, 1994) (Fig. 5B). This most well-known Gutien method widely used on a large scale in China was described in detail by Ting (1994) and Chang and Miles (2004). Development of shiitake sawdust cultivation can be traced back to the early 1970's, and Shanghai was a center for such innovation in 1974. Today, the latest development in the U.S. is the use of much larger sawdust-substrate blocks in sealed polypropylene bags with micro-porous filters as breathing windows (Fig. 5C). This methodology lends itself to faster and greater productivity by mixing the spawn thoroughly with the substrate which produces more flushes of mushrooms in much shorter growing cycles. Shiitake produces 3-5 flushes of mushrooms per year on natural logs. With synthetic substrates, each flush of shiitake requires only 16-20 days. Sawdust cultivation may produce 3-4 times as many mushrooms as natural logs in only one tenth of the time (Royse, 2002). It is also very easy to use this growing process to manage the spawn run. In Europe, more substrate in larger bags is used. Each bag contains 15 kg of substrate shaped in a flat slate (Fig. 5D). The growing cycle in Europe is usually shorter than in South East Asia, but longer than in the U.S. (Oei, 2003).

The benefits of modern sawdust cultivation include a consistent market supply through year-round production to meet consumer demand. Moreover, sawdust cultivation is a means to utilize agricultural wastes (Lopez, Valencia and Chang, 2004) and spent mushroom substrates (Babcock, 2004) to generate food.

The three major milestones in the history of shiitake cultivation are summarized in Table 1.

**Table 1.** Three major milestones in shiitake cultivation

Discovery	Discoverer	Country	Time
<b>1. Spontaneous log cultivation in nature</b>	Wu San Kang	China	1100
<b>2. Pure culture spawn</b> in log cultivation	K. Kitajima	Japan	1936
Pure culture technique	S. Mimura	Japan	1904 1915
<b>3. Sawdust cultivation in cylindrical synthetic logs in plastic bags</b>	Z. W. Peng	China	1983
- Sawdust cultivation	Shanghai	China	1974
- Sawdust blocks, 5-6kg(w/w) in sealed polypropylene bags	—	The U.S.	1989
- Sawdust substrate slate, 15kg in large plastic bag	—	Europe	Recent

## Nutritional Requirements and Environmental Factors for Shiitake Cultivation

Nutritional requirements (carbon source, nitrogen source, C/N ratio, minerals and trace elements, and vitamins) and environmental factors (temperature, moisture, oxygen-air, light and pH value of the substrate) are important considerations in shiitake cultivation (Ting, H.K., 1994 and others).

### Nutritional requirements

As a saprophytic white-rot fungus, shiitake produces mycelia during its most vigorous vegetative growing phase. Mycelia can absorb small molecules of nutrients directly, but it is necessary to break down the complex food molecules in the environment first by secreting enzymes from the mycelia to decompose these complex lignocellulosic substances that serve as the shiitake's major carbon source. Shiitake use protoplasm in growing tree bark and xylem as a nitrogen source, and absorb a small amount of soluble substances as well as minerals from xylem and phloem in wood.

### Carbon source

Carbon is the most important required nutrient for shiitake. Carbon is the building block for protein, nucleic acids, and

<sup>6</sup> pure culture spawn: spawn made from one species of mushroom

<sup>7</sup> pure culture technique: using one species under sterile conditions

sugars in the living cells. Carbon is also the major component for the energy source used for oxidation in the metabolism. Carbon usually comes from organic compounds such as sugars, organic acids, alcohols, starch, cellulose, hemicellulose, and lignin.

### Nitrogen source

Nitrogen is indispensable for building protoplasm<sup>8</sup> and cell structural elements in shiitake. The major sources of nitrogen are organic and inorganic nitrogen compounds including urea and proteins. Nitrogen sources are distributed unevenly in wood logs. Nitrogen content is highest in the cambium<sup>9</sup>, and lowest in the heartwood<sup>10</sup>. Tree bark contains 3.8-5% nitrogen, while xylem<sup>11</sup> contains only 0.4-0.5 % nitrogen.

### C/N ratio

Materials with a carbon to nitrogen ratio of 25:1 are the best for vegetative mycelial growth, while materials with a C/N of 40:1 are the best for the mushroom production phase. Too much nitrogen may allow the shiitake mycelium to grow luxuriously in the spawn run, but these colonized blocks will not produce good mushrooms. The most suitable nitrogen concentration during the vegetative phase is 0.016-0.064%, while 0.02% is the best for reproductive phase. Primordia formation and the subsequent formation of fruiting bodies are both sensitive to nitrogen concentrations, and ideally the nitrogen concentration during these phases should not be over 0.02%.

### Minerals and trace elements

**Table 2.** Carbon to nitrogen ratio (C/N) and nitrogen concentration in shiitake production

	Best for mycelial growth	Best for fruiting
C/N	25:1	40:1
N-concentration	0.016-0.064%	0.02%

The major mineral elements, such as phosphorus, sulfur, calcium, magnesium and potassium are used for building cell components and enhancing metabolism. Some minerals maintain balanced cellular osmotic pressure in cells. Phosphorus and potassium, in particular, are not only beneficial to mycelial growth, but also to the formation of fruiting bodies. The trace elements, Fe, Cu, Zn, Mn, B, and Mo are components or catalysts for enzymes. The required amounts of these trace elements are minute. Inorganic compounds, such as  $\text{KH}_2\text{PO}_4$ ,  $\text{K}_2\text{HPO}_4$ , gypsum, magnesium phosphate, at concentrations of 100-500mg, are usually used in making substrates. It is not necessary to add trace elements as they are usually contained in water or substrate ingredients.

### Vitamin B<sub>1</sub> (thiamin)

Vitamin B<sub>1</sub> is required for shiitake mycelial growth and fruiting. Fresh coarse (not refined) rice or wheat bran in the substrate contains such vitamins. Vitamin B<sub>1</sub> is sensitive to heat. It decomposes above 120 °C, so overheating during substrate sterilization should be avoided.

### Environmental factors<sup>12</sup>

#### Temperature

Shiitake are fungi of temperate climates. They require low temperatures and temperature fluctuations in order to form fruiting bodies. In the shiitake metabolic processes, all of the physical and chemical reactions are controlled by temperature, and the numerous enzymes all have their own optimal activity temperatures. When temperatures are too high, protein molecules in the enzyme may be denatured and lose their viability. When temperatures are too low, it is difficult for the nutrients to be absorbed, enzymatic activity becomes lower, and the rate of respiration slows down. These lower rates result in a decrease in mycelial growth. The optimal temperature for shiitake mycelial growth is 24-27 °C. The species can be adapted to grow in a wide range of temperatures from 5 to 32 °C. Shiitake tolerate cold temperatures. In winter-like temperatures of 8-10 °C, shiitake mycelia are still viable even after 30-40 days. However, shiitake are vulnerable to the high temperatures of summer. Shiitake mycelia stop growing above 34 °C and turn yellow. Serious mycelial damage occurs at 36 °C. Mycelia turn reddish and die above 40 °C<sup>13</sup>.

<sup>8</sup> protoplasm: living material outside the nucleus of a cell

<sup>9</sup> cambium: thin layer of generative tissue lying between the bark and the wood of a stem, most active in woody plants

<sup>10</sup> heartwood: see page 58

<sup>11</sup> xylem: a tissue that forms the stem of woody plant. It conducts sap upward from the roots to the leaves, stores food in the form of complex carbohydrates, and provides support.

<sup>12</sup> For detailed information on environmental conditions for shiitake cultivation, see SHIITAKE BAG CULTIVATION in Chapter 4.

<sup>13</sup> For detailed information on shiitake strains, with variation in their temperature requirements for fruiting, see SHIITAKE BAG CULTIVATION in Chapter 4.

**Table 3.** Shiitake temperature requirements at different stages

Stage	Temperature range (°C)	Optimal temperature range (°C)
Spore germination	15-28	22-26
Mycelial growth	5-32	24-27
Fruiting	5-25	15 ± 1-2 (strain dependent)

### Moisture

Water is vital for shiitake growth and production. Nutrients need to be dissolved in water in order to be absorbed by mycelia. Likewise, metabolic wastes need to be dissolved in water in order to be disposed from the mycelia. The proper amount of moisture is required for metabolism. It is important to provide and maintain the optimal moisture content in the substrate for growing shiitake. It is also important to maintain optimal relative humidity (R.H.) of the air according to the different growth stages.

**Table 4.** Moisture and humidity requirement for shiitake (under Chinese system)

Stage	Substrate moisture content	R. H.	Adverse growing conditions
Mycelial growth	55%	< 75%	Moisture < 50%, growth slow Moisture > 65%, growth weak Moisture > 75%, contamination
Fruiting	50-55%	85-95%	Moisture < 30%, difficult to produce mushrooms Moisture > 95%, producing rotten mushrooms

### Air

Shiitake are aerobic fungi. During the process of their metabolism, depending upon the availability of oxygen, organic compounds are oxidized through respiration. Energy thus released is stored in ATP to be used for mycelial growth and fruiting. Different stages of shiitake production require different amounts of oxygen. More oxygen is required during the reproductive phase than during the vegetative mycelial growth stage. A well-ventilated room with fresh air is necessary for the vigorous mycelial growth that produces carbon dioxide. During fruiting body formation, the requirements for oxygen are higher, and the concentrations of carbon dioxide released are also higher. It has been reported that each shiitake can produce 0.06g CO<sub>2</sub> per hour.

Well-circulated fresh air and more frequent ventilation during the reproductive phase are important. Fresh air contains 0.03% CO<sub>2</sub>, and a concentration of CO<sub>2</sub> greater than 1% inhibits the development of fruiting bodies and causes the mushroom caps to open early. At high CO<sub>2</sub> concentrations malformation of shiitake mushrooms occurs. When the CO<sub>2</sub> levels reach 5% the failure of fruiting body formation is observed.

### Light

Light is the direct or indirect source of energy for shiitake. Light is required for basidiospore formation and dispersal. Mycelia can grow in darkness without light. Under weak diffused light, mycelia grow better than under direct strong light which inhibits mycelial growth. In darkness, mycelia grow 3-4 times faster than under 500 lux. Light is required for shiitake fruiting body formation. The optimal light level is 50-100 lux of diffused light during fruiting.

### pH of the substrate

Extra-cellular enzymes function at a specific pH range in degrading the substrate, and substrate pH is thus of great importance. Shiitake prefer an acidic environment. They can grow at a wide range of pH 3-7 with the optimal pH range being 4.5-5.5. The best range for primordia formation and fruiting body formation is pH 3.5-4.5. Initial substrate pH is usually pH 5-6. As mycelia grow, organic acids are produced, which decrease the pH of the substrate. K<sub>2</sub>HPO<sub>4</sub> and KH<sub>2</sub>PO<sub>4</sub> are usually added to the substrate to buffer and stabilize the pH. The wood, straw and water used for shiitake cultivation usually have an appropriate pH and do not need to be adjusted. Attention should be paid when the available water is alkaline in nature.

The keys for successful cultivation of shiitake include; 1) A well-supplemented substrate with balanced nutrition and

optimal C/N and pH is invaluable, 2) At each different growing and fruiting stage, a different set of environmental conditions are required. Knowing how to create optimal conditions as shiitake grow will enable the grower to produce high yields of the best quality mushrooms.

## World Shiitake Production and Consumption

World production of mushrooms is being dominated increasingly by species which are both edible and have medicinal benefits. Shiitake now ranks number one in specialty mushroom production. Current trends in mushroom production and consumption (Table 5) steer towards fresh shiitake consumption, particularly in the main markets in the U.S. and Europe. There is wide-spread interest worldwide both in mushroom production and consumption. Asia, where mushroom cultivation originated, remains strong in mushroom industry. China is leading in mushroom production with 8,650,000 tons produced in 2002 (Zhang, 2004).

**Table 5.** World production of cultivated mushrooms in 1986 and 1997 (fresh weight/1,000 tons)

Species	1986	1997	Growth rate (%)
<i>Agaricus bisporus</i>	1,227 (56.2%)	1,956 (31.8%)	59.4
<i>Lentinula edodes</i>	314 (14.4%)	1,564 (25.4%)	398.1
<i>Pleurotus</i> spp.	169 (7.7%)	876 (14.2%)	418.3
<i>Auricularia</i> spp.	119 (5.5%)	485 (7.9%)	307.6
<i>Volvariella volvacea</i>	178 (8.2%)	181 (2.9%)	1.7
<i>Flammulina velutipes</i>	100 (4.6%)	285 (4.6%)	130.0
<i>Tremella</i> spp.	40 (1.8%)	130 (2.1%)	225.0
<i>Hypsizygus</i> spp.	N/A	74 (1.2%)	-
<i>Pholiota</i> spp.	25 (1.1%)	56 (0.9%)	124.0
<i>Grifola frondosa</i>	N/A	33 (0.5%)	-
Others	10 (0.5%)	518 (8.4%)	5,080.0
Total	2,182 (100.0%)	6,158 (100.0%)	182.2

Source: Chang, 1999 and Royle, 2004

**Table 6.** Trends of mushroom production and consumption

1. Dramatic increase in mushroom production
2. Species diversity towards specialty mushrooms
3. High interest in mushrooms both edible and with medicinal benefits
4. Fresh-mushroom consumption in shiitake in the U.S. and Europe
5. Wide-spread of interest worldwide both in mushroom production and consumption
6. Mushrooms as an international business
7. Mushroom production as an environmental-sound practice in converting wastes into a valuable food

## The dynamics of global shiitake production

Shiitake production became an industry in Japan after World War II. Over 20 years ago in 1983, 171,200 tons fresh equivalent weight of shiitake with a value of USD689 million were produced by almost 167,000 growers in Japan. In 1983 alone, Japan accounted for more than 82.0% of the total world production of shiitake. During the same period, China produced only 9.4% (Table 7). Only 4 years later, China overtook Japan for the first time in 1987 as the leading shiitake producer with a production volume of 178,800 tons. Since its peak production of 240,771 tons equivalent fresh weight in 1984, the volume of shiitake

production has declined in Japan. China has maintained its position as the shiitake production leader since 1987.

Today in China, the cultivation of shiitake is an important agricultural industry. An estimated of 18 million farmers are engaged in shiitake production and a steady increase in annual output has occurred in recent years. In 2002, the total production of shiitake was estimated to be 2 million tons in fresh weight, of which 45,000 tons of shiitake were exported to other countries and regions (Luo, 2004). The shiitake production figures from the U.S. are posted annually by United States Department of Agriculture (USDA) and the Mushroom Growers' Newsletter. The value of commercially grown specialty mushrooms in the 2002-2003 season totaled USD37.7 million. Included in this survey was the sale of USD25.3 million from the volume of 8.25 million pounds of shiitake produced by 217 shiitake growers (USDA, 2004). There is evidence of a new trend towards consuming and growing shiitake worldwide.

**Table 7.** World production of shiitake in different years (fresh weight/1,000 tons)

Country	1983		1985		1991		1994		1997	
	Volume	Share (%)	Volume	Share (%)	Volume	Share (%)	Volume	Share (%)	Volume	Share (%)
China	19.5	9.4	50.0	13.9	380.0	60.5	626.0	73.6	1,125.0	85.1
Japan	171.2	82.8	227.3	63.3	179.7	28.8	157.4	18.5	132.6	10.0
Taiwan	7.5	3.6	49.0	13.7	36.8	5.9	28.0	3.3	27.0	2.1
Korea	4.9	2.4	23.4	6.5	17.2	2.7	22.0	2.6	17.0	1.3
Others	3.6	1.7	9.4	2.6	14.5	2.3	17.0	2.0	20.0	1.5
Total	208.7	99.9	359.1	100	638.2	100	850.4	100	1,321.6	100

Source: Chang and Miles, 2004

### Shiitake production in different parts of the world

Oei (2003b) analyzed trends in the shiitake sector in Europe. The recent studies of Lahman and Rinker (2004) showed mushroom production in South America, Central America, and Mexico in North America (Table 8). Latin America has continued to increase in mushroom production. South America produced about 94% of the shiitake in Latin America, with Brazil ranking highest.

**Table 8.** Estimated annual production of white button mushroom (*Agaricus*) and shiitake in Latin America in 2002

Country	White button mushroom (ton)	Shiitake (ton)
South America		
Argentina	1,500	8
Bolivia	10	2
Brazil	6,885	800
Chile	4,872	0
Colombia	6,312	3.6
Ecuador	625	0
Peru	750	0
Venezuela	1,320	0
Sub total	22,274	813.6
Central America		
Costa Rica	90	3
Guatemala	80	30
Sub total	170	33

North America			
	Mexico	37,230	30
<b>Total</b>		<b>59,674</b>	<b>876.6</b>

Source: Composite from Lahman and Rinker (2004)

### Shiitake consumption patterns

Shiitake were originally highly treasured Asian mushrooms with great flavor, taste, and an enticing aroma. They are also well-known for their medicinal benefits in strengthening the immune system. Asian populations worldwide continue to favor shiitake, whether fresh or dried. In the cosmopolitan cities in different corners of the world, gourmet restaurants feature shiitake dishes on their menu. Limited marketing studies show females, the traditional main grocery shoppers, may consume more mushrooms including shiitake than males. Bing and Li (2004) analyzed consumer buying behavior for fresh shiitake in Japan, while Brownlee and Seymour (2004) targeted Australians for consumer research on mushroom consumption. Factors that may effect shiitake consumption include consumers' ethnic and cultural backgrounds, tastes for food, ages, sex, perception and knowledge of mushroom products, mushroom image and consumers' income.

Projection of a positive and appealing mushroom image is vital. Shiitake appeals to health-conscious populations as well as vegetarians for its attributes of high nutrition, quality protein, essential amino acids, low calorie content, and health benefits. In regions where edible mushrooms are not a traditional food, demand for mushrooms such as shiitake depends on the continuous effort of the mushroom producers and industry in educating the consumers. Mushroom growers in Nepal were reluctant to grow shiitake because it is not a familiar native species.

### Shiitake prices

Mushroom Growers' Newsletter ([www.MushroomCompany.com](http://www.MushroomCompany.com)), a monthly publication, posts U.S. weekly mushroom wholesale market prices in Chicago, Dallas, Miami, New York and San Francisco. It also lists mushroom world spot prices per pound in USD. For the week of November 22, 2004, the wholesale market price per pound for shiitake in New York was USD 5.00-5.33 for jumbo size, USD3.67-4.33 for large and USD2.67-3.17 for #2 small. The retail shiitake prices at regional super markets in upstate New York in the U.S. are usually USD7.99/lb. Shiitake prices at international markets were Tokyo, Japanese shiitake, USD2.90-9.20/100g; Chinese shiitake USD0.37-41.11 for 5kg box (Nov. 22, 2004), Paris, USD4.09-4.36/lb. (Nov. 4, 2004), Toronto, Canada, USD4.19-5.60 per 3lbs (Nov. 17, 2004), Montreal, Canada, USD6.77-7.82 per 3lbs (Nov. 17, 2004).

In Colombia, the retail price of 1kg of selected and packed shiitake was COP<sup>14</sup>16,000 (USD6.87), while the production costs including salary was COP10,000 (USD4.30) in 2002 (Lopez *et al.*, 2004).

**Table 9.** Shiitake price in the world

Market	Size / Quality	Unit	Price in USD	Date
New York (wholesale market)	Jumbo	Pound	5.00-5.33	November 22, 2004
	Large	Pound	3.67-4.33	
	#2	Pound	2.67-3.17	
New York (retail market)	Average	Pound	7.99	
Tokyo	Japanese shiitake	100g	2.90-9.20	
	Chinese shiitake	5kg	0.37-41.11	
Paris		Pound	4.09-4.36	November 4, 2004
Toronto		3 pound	4.19-5.6	November 17, 2004
Montreal		3 pound	6.77-7.82	November 17, 2004
Colombia (retail market)		1kg	6.87	2002

<sup>14</sup> COP (Colombian Peso, USD1 : COP2,325.58 in March, 2005)

## Shiitake Cultivation for Poverty Alleviation

### The example of Qingyuan, China

In the light of the mission of MushWorld of alleviating hunger in poverty-stricken regions in the world by encouraging the cultivation of mushrooms, the study of shiitake production in Qingyuan county could be interesting. Qingyuan in China, declared by Chinese government as “Shiang-Gu city of China,” was the birth place of spontaneous shiitake log cultivation in 1100 A.D.. The county of Qingyuan is located in a warm monsoon climate. Such a climate is considered ideal for shiitake production at high elevations. Sixty percent of the population of less than 200,000 in Qingyuan county engage directly in growing shiitake. Today the majority of the farmers (80%) use sawdust for growing shiitake. The production of shiitake has increased from 2,765 tons in 1986 to 106,500 tons in 1997. The total value of mushroom production in 1997 reached USD46.3 million. Qingyuan is now one of the richest counties among some 3,000 counties in China. The flourishing of the economy in Qingyuan is solely due to the cultivation and marketing of shiitake. The assistance of the local government in creating a trading floor has played an important role in the growth of the shiitake industry (Chang and Miles, 2004).



Figure 6. Market for dried shiitake in Qingyuan, China

Su Decheng, a mushroom scientist, who lived in poverty himself during his first 16 years in life in the mountainous region of Fujian Province in southeast China, vowed to help his countrymen get out of poverty by studying mushroom science. In 1989, he took part in a project to help people in poverty-stricken areas of China learn how to grow mushrooms for self-sufficiency. Using his knowledge of mushroom cultivation and his experience of successfully running the Youxi Shanglin Mushroom Farm, he went to Nanpin County with 20 mushroom science students to train the local people how to grow shiitake on sawdust. They established a mushroom farm to demonstrate to the locals how mushrooms could be cultivated.

In another location in Shouling County in Fujian, there were 70,000 people in 14,000 rural families living well below the poverty level with a yearly income of less than CNY15300 (USD36.01). The land here was barren, producing only scrub wood and little grain. In 1989, Su and his students trained them how to grow mushrooms. Almost all the families participated in this shiitake cultivation project. Since then, growing mushrooms has become increasingly economically important in this county. The average annual income per *capita* reached CNY1,800 (USD216.09) in 1993, six times higher than in 1989 when the project was first initiated. Three quarters of their income came from producing mushrooms. This vivid report demonstrates the incredible impact mushroom farming had on Shouling County in Fujian, China. More than a dozen such successful examples of shiitake cultivation in Fujian, Zhejiang, Henan and Hebei Province are quoted in Wu (2000).

### Mission of Zero Emission Research Initiative (ZERI)

Table 10. Wastes from industry for mushroom cultivation

Industry	Usable biomass	Waste
The flax industry	2%	98%
The brewing industry	8% of the grain's nutrients	92%
The palm oil industry	< 9%	> 81%
The cellulose industry	< 30%	> 70%
The coffee industry	9.5% of the weight of the fresh material	90.5% residue waste

On our planet earth, an estimated 155 billion tons of organic matter are produced annually through photosynthesis (Rajaratnam *et al.*, 1991). However, only a small portion of this organic matter is directly edible by humans and animals. The bulk of such organic matter can not be used as food, but becomes a source of environmental pollution. Examples of wastes from industry which can be used in mushroom cultivation are shown in Table 10. Growing mushrooms is one of the ways the ZERI methodology makes value-added products from the waste of several industries. Lopez *et al.* (2004) showed how valuable shiitake mushrooms can be grown on coffee waste in Colombia to increase farmers' income<sup>16</sup>. As decomposers, mush-

<sup>15</sup> CNY (Chinese Yuan, USD1 : .CNY8.33 in March, 2005)

<sup>16</sup> For detailed information, see MUSHROOM GROWING PROJECT IN COLOMBIA in Chapter 9

rooms secrete enzymes which break down the complex molecules of plant wastes. In the process of such degradation, mineral elements including carbon are released for “recycling”, thus creating an enormous ecological impact. Shiitake can be cultivated at altitudes of 1,300-1,700m above sea level in coffee growing regions. Maintaining 10-23 °C during shiitake fruiting was achieved by spraying the floors and the walls with cold water containing 5% sodium hypochlorite to prevent mold contamination.

**Table 11.** Impacts and benefits of mushroom cultivation

1. Use of wastes in sustainable forestry
2. Use of wastes in the integrated waste management
3. Use of wastes in farming system
4. Use of wastes in the beer industry
5. Producing a valuable food source
6. Producing nutraceuticals and nutraceuticals for health benefits
7. Innovation: such as using mushroom spent substrates in growing earthworms for fishing or soil conditioning

## Conclusion

For the study of technology in shiitake production, China and the U.S. are good models. Latin America is an example of emerging shiitake markets where shiitake was not a traditional food. Much of the world’s undernourished population are in subtropical and tropical regions. Studies on shiitake production under such climates, such as in Latin America, will be helpful in encouraging mushroom growing in other parts of the world to alleviate poverty.

## REFERENCES

- Bing, C., and L. Li. 2004. Analysis of consumer buying behavior for fresh shiitake. In: Romaine, Keil, Rinker, and Royse, eds: *Mushroom Science: Science and Cultivation of Edible and Medicinal Fungi*. University Park, PA: The Pennsylvania State University Press. pp. 663-670.
- Bisko, N.A., V.T. Bilay, V.G. Babitskaya, V.V. Scherba, N.Y. Mitropolskaya, and T.A. Puchkova. 2004. Biologically active substances from mycelia of *Ganoderma lucidum*, and *Lentinula edodes*. In: Romaine, Keil, Rinker, and Royse, eds: *Mushroom Science: Science and Cultivation of Edible and Medicinal Fungi*. University Park, PA: The Pennsylvania State University Press. pp. 619-623.
- Chang, S.T., and P.G. Miles. 2004. *Mushrooms: Cultivation, Nutritional Value, Medicinal Effect and Environmental Impact*. 2<sup>nd</sup> ed. CRC Press.
- Chen, A.W. 2004. Growing shiitake mushrooms. In: *Mushroom Growers’ Handbook 1: Oyster Mushroom Cultivation*. Seoul, Korea: MushWorld. pp. 248-261.
- Chen, A.W. 2001. Cultivation of *Lentinula edodes* on synthetic logs. *Mushroom Growers’ Newsletter* 10(4): 3-9.
- Chen, A.W., N. Arnold, and P. Stamets. 2000. Shiitake cultivation systems. In: van Griensven L.J.L.D., ed: *Science and Cultivation of Edible Fungi*. pp. 771-778.
- Lahman, O., and D.L. Rinker. 2004. Mushroom practices and production in Latin America: 1994-2002. In: Romaine, Keil, Rinker, and Royse, eds: *Mushroom Science: Science and Cultivation of Edible and Medicinal Fungi*. University Park, PA: The Pennsylvania State University Press. pp.681-686.
- Lopez, C.J., N.R. Valencia, and S.T. Chang. 2004. Cultivation of shiitake on coffee waste. In: Romaine, Keil, Rinker, and Royse, eds: *Mushroom Science: Science and Cultivation of Edible and Medicinal Fungi*. University Park, PA: The Pennsylvania State University Press. pp. 307-311.
- Luo, X.C. 2004. Progress of xiang-gu (shiitake) cultivation in China. In: Romaine, Keil, Rinker, and Royse, eds: *Mushroom Science: Science and Cultivation of Edible and Medicinal Fungi*. University Park, PA: The Pennsylvania State University Press. pp. 317-322.
- Oei, Peter. 2003a. *Lentinula edodes* (shiitake) cultivation on sterilized substrates, on wood logs. In: *Mushroom Cultivation*. 3<sup>rd</sup> ed. Leiden, the Netherlands: Backhuys. pp.303-324, 325-341.
- Oei, Peter. 2003b. Trends in the shiitake sector. *Mushroom Business* Dec. 2003. pp.14-15.
- Rajarathnam, S., and Z. Bano, 1991. Biological utilization of edible fruiting fungi. In: Arora, D., K. Mukerji, and E. Math, eds: *Handbook of Applied Mycology, Foods and Feeds*. New York, USA: Marcel Dekker. Inc. Vol.3.
- Royse, D. 2004. Specialty mushrooms. In: *Mushroom Fact Sheet*. Mushroom Spawn Laboratory, Pennsylvania State University Stat Park, PA: Department of Plant Pathology.
- Stamets, P. 2000. *Growing Gourmet and Medicinal Mushrooms*. Berkeley, Toronto: Ten Speed Press.
- Wu, J.L. (ed.). 2000. *Shiitake Production in China*. Beijing, China: Agricultural Press (in Chinese).
- Zhang, X.Y. 2004. *Small Mushrooms: Big Business. Inception Report* (Mar. 2004) The Hague, the Netherlands: Agricultural Economics Research Institute (LEI).

Part I Shiitake

Chapter 1

What is Shiitake

NUTRITIONAL AND MEDICINAL VALUES OF SHIITAKE

Hyunjong Kwon (Miji)<sup>1</sup> and Christopher Hobbs<sup>2</sup>

<sup>1</sup>MushWorld, 150-5 Pyungchang, Jongro, Seoul, Korea (hjkwon@mushworld.com)

<sup>2</sup>Institute for Natural Products Research, The U.S.

Shiitake has long been favored by Asian people as a gourmet and medicinal mushroom. They eat shiitake stir-fried, in soup and in decoction (Figs. 1). Today shiitake is found in markets throughout North America and Europe as well as Asia (Figs. 2, 3 and 4). It is the world's 2nd most commonly cultivated mushroom. Shiitake's popularity is ever increasing throughout Asia, North America, Europe and other parts of the world, partly because of its exotic flavor and partly because of its nutritional and various medicinal properties.

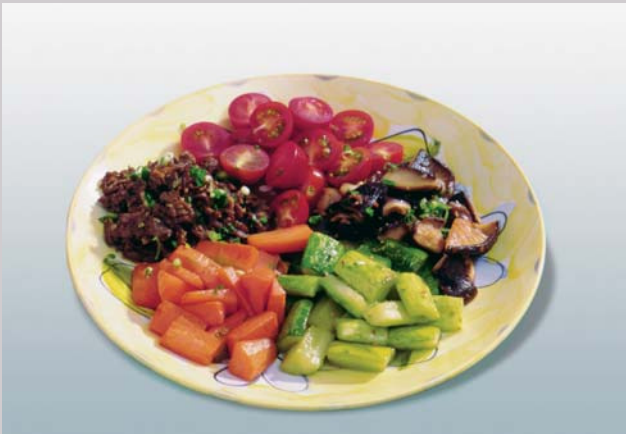


Figure 1. Asian cuisine with shiitake



Figure 2. Dried, sliced shiitake in U.S.A., Japan and Korea



Figure 3. Fresh shiitake in retail and wholesale markets



Figure 4. Leaflet about shiitake in a European country

## Nutritional Health Benefits

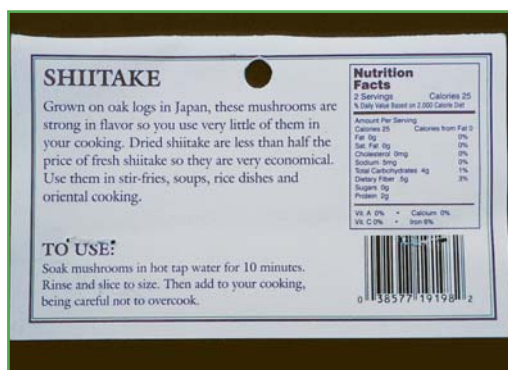


Figure 5. Nutrition facts on a package of dried shiitake

This delicate mushroom is also excellent in its nutritional value. It is a particularly good source of minerals and vitamins B<sub>1</sub> (thiamin), B<sub>2</sub> (riboflavin), B<sub>3</sub> (niacin) and D. It also contains all the essential amino acids and dietary fiber<sup>1</sup>.

The caloric value of 100g of dried shiitake is higher than 100g of raw potatoes (80kcal) or beef loin (224kcal), but lower than that of whole wheat or brown rice (328-350kcal). The protein content of dried shiitake is comparable to that of chicken, pork and beef but the fat count is much lower and the dietary fiber count is considerably higher than those meats (Table 1). Shiitake contains almost all the essential amino acids, with lysine and arginine being particularly abundant (Liu and Bau, 1980), and methionine and phenylalanine less abundant (Lasota and Sylwestrzak, 1989). In laboratory analysis it was found that amino acids, protein, glycogen, lipids, ascorbic acid, and total ash contents increased as the fruiting body developed (Fasidi and Kadir, 1990). Based on these findings, it may be desirable to consume fully mature fruiting bodies for maximum nutritional value. The researchers generally found higher concentrations of nutrients in the cap than the stem of the fungus. Shiitake contains dietary fiber in the ratio of 6.7g per 100g of dried shiitake, which is a figure much higher than that for brown rice (0.2g), and sweet potatoes (0.9g). Dietary fiber prevents constipation, obesity, diabetes, hypertension, colon cancer and arteriosclerosis by lowering cholesterol level. In addition to dietary fiber, dried shiitake contains higher contents of potassium (K), iron (Fe), phosphorus (P) and vitamin B and D than most food sources. But it does not contain vitamins A and C (Table 1).

The high amount of ergosterol in fresh shiitake makes dried shiitake an important vitamin D source because ergosterol converts to vitamin D<sub>2</sub> in the presence of sunlight. Studies have shown that exposing shiitake to direct sunlight for 3 hours/day increases the vitamin D<sub>2</sub> content up to 5 times. Sunlight exposure also increases the free amino acid content which is about 2,180mg/dl in the dry fruiting bodies, and it makes them sweeter and less bitter (Kiribuchi, 1991).

Eating shiitake can prevent various vitamin B and D deficiencies including beri-beri<sup>2</sup> (thiamin); cheilosis<sup>3</sup>, glossitis<sup>4</sup>, corneal vascularization<sup>5</sup>, Seborrheic dermatitis<sup>6</sup>, nerve tissue damage (riboflavin); abnormal growth in infants and children (niacin); and rickets<sup>7</sup> (vitamin D). Vitamin D boosts calcium absorption and thus plays an important role in bone formation.

Eating shiitake can prevent various vitamin B and D deficiencies including beri-beri<sup>2</sup> (thiamin); cheilosis<sup>3</sup>, glossitis<sup>4</sup>, corneal vascularization<sup>5</sup>, Seborrheic dermatitis<sup>6</sup>, nerve tissue damage (riboflavin); abnormal growth in infants and children (niacin); and rickets<sup>7</sup> (vitamin D). Vitamin D boosts calcium absorption and thus plays an important role in bone formation.

<sup>1</sup> dietary fiber: coarse, indigestible plant matter, consisting primarily of polysaccharides, that when eaten stimulates intestinal peristalsis

<sup>2</sup> beri-beri: disease involving swelling, tingling or burning sensation in the hands and feet, confusion, difficulty breathing (from fluid in the lungs), and uncontrolled eye movements

<sup>3</sup> cheilosis: cracking at the corners of the mouth and inflammation of the mucous membranes in the mouth

<sup>4</sup> glossitis: swollen and reddened tongue

<sup>5</sup> corneal vascularization: reddening, burning, itching of the eyes and sensitivity to light

<sup>6</sup> Seborrheic dermatitis: unusual dryness and greasy scaling of the skin

<sup>7</sup> rickets: a childhood disorder involving softening and weakening of the bones

**Table 1.** Constituents of dried/fresh shiitake grown on different logs and other food sources (per 100g edible portion)

Food source	Energy (Kcal)	Moisture (%)	Protein (g)	Fat (g)	Ash (g)	Carbohydrates (mg)	
						Sugar	Fiber
Shiitake							
Dried / pitch pine	261	11.6	17.3	1.7	4.8	57.9	6.7
Dried / alder	277	11.0	14.2	2.7	2.8	62.5	6.5
Dried / Mongolian oak	277	8.9	17.1	2.5	3.7	60.8	7.0
Dried / oak	272	10.6	18.1	3.1	4.5	57.0	6.7
Fresh / oak	27	90.8	2.0	0.3	0.8	5.4	0.7
Other foods							
Whole wheat	328	11.8	12.0	2.9	1.8	69.0	2.5
Brown rice	350	11.6	7.6	2.1	1.6	74.4	2.7
Potato (raw)	66	81.4	2.8	Ø*	1.1	14.4	0.2
Chicken (meat)	180	69.4	19.0	10.6	0.9	0.1	0
Pork (loin)	262	61.5	17.4	19.9	1.0	0.2	0
Beef (loin)	224	65.5	17.5	15.9	0.9	0.2	0

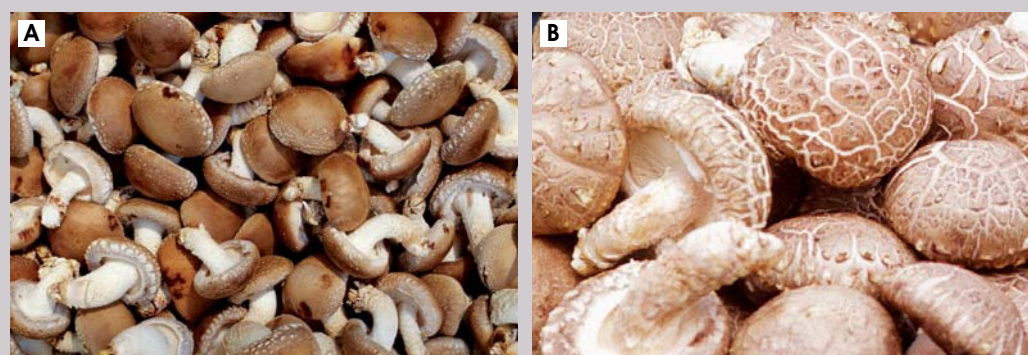
Food source	Minerals (mg)					Vitamins (mg)				
	Ca	P	Fe	Na	K	A***	B <sub>1</sub>	B <sub>2</sub>	B <sub>3</sub>	C
Shiitake										
Dried / pitch pine	20	206	3.6	**	-	0	0.66	1.61	7.7	0
Dried / alder	16	352	7.4	-	-	0	0.62	1.05	6.4	0
Dried / Mongolian oak	16	343	6.9	-	-	0	0.70	1.56	9.8	0
Dried / oak	19	268	3.3	25	2,140	0	0.48	1.57	19.0	0
Fresh / oak	6	28	0.6	5	180	0	0.08	0.23	4.0	Ø
Other foods										
Whole wheat	71	390	3.2	3	380	0	0.34	0.11	5.0	0
Brown rice	6	279	0.7	79	326	0	0.23	0.008	3.6	0
Potato (raw)	4	63	0.6	3	485	0	0.11	0.06	1.0	36
Chicken (meat)	11	110	1.1	58	327	50	0.20	0.21	2.7	0
Pork (loin)	6	152	0.8	34	291	5	0.61	0.15	7.4	0
Beef (loin)	15	159	1.6	44	333	6	0.07	0.23	4.3	0

\*Ø: trace or nil

\*\*.: not detected

\*\*\*Unit: Vitamin A (RE)

Source: National Rural Living Science Institute, R.D.A. Korea, 2001

**Figure 6.** Fresh (A) and dried (B) shiitake

## Medicinal Health Benefits



Figure 7. Shiitake (*Lentinula edodes*) fruiting body

Asian people have enjoyed shiitake fruiting bodies for ages as a folk or traditional medicine. Modern medicine has come up with more purified, concentrated shiitake derivatives. Among them, “lentinan” and “LEM” are the most frequently studied compounds. In the following sections, major published laboratory and clinical work available on the anti-tumor/ anti-viral/ anti-bacterial/ hepatoprotective effects, as well as cardiovascular effects will be reviewed.

### Major active compounds isolated from *Lentinula edodes*

#### Lentinan

- a cell-wall constituent extracted from the fruiting bodies or mycelium of *L. edodes*
- a highly purified, high molecular weight polysaccharide (of about one million)
- containing only glucose molecules with mostly  $\beta$  - (1-3)-D-glucan linkages
- free of any nitrogen (and thus protein), phosphorus, sulfur, or any other atoms except carbon, oxygen, and hydrogen (Chihara, 1981)
- water-soluble, heat-stable, acid-stable, and alkali-labile (Aoki, 1984b)

#### LEM

- *Lentinula edodes* mycelium extract
- a preparation of the powdered mycelia extract of *L. edodes* harvested before the cap and stem grow
- containing a heteroglycan protein conjugate, that is, a protein-bound polysaccharide
- containing protein, sugars, mostly the pentoses, including xylose (a wood sugar) and arabinose (a pectin sugar), as well as glucose and smaller amounts of galactose, mannose, and fructose
- containing nucleic acid derivatives, vitamin B compounds, especially B<sub>1</sub> (thiamin) and B<sub>2</sub> (riboflavin); ergosterol; and eritadenine (Breene, 1990)
- also containing water-soluble lignins (Hanafusa *et al.*, 1990)

#### KS-2

- a polysaccharide containing  $\alpha$ -linked mannose and a small amount of peptide
- Fuji *et al.* isolated

#### JLS

- a compound derived from the mycelium
- JLS-18, consisting of lignin, polysaccharides and proteins

#### Eritadenine

- a nucleic acid derivative

#### EPS and EPS4

- water soluble lignins

### Anti-tumor effects

Most people who enjoy mushrooms, as well as health-care practitioners, seem to be quite interested in whether and what medicinal effects shiitake has in its whole, powder or extract form. Study results have shown that shiitake and its derivatives, especially lentinan and LEM, have strong anti-tumor/ anti-viral activities, when taken both orally and by injection, both in animals and in humans. These substances were found to work by enhancing various immune system functions rather than attacking the tumor cells or viruses themselves.

## Animal tests



**Figure 8.** Powdered shiitake fruiting bodies

When powdered shiitake was fed to tumor-implanted mice as 10% of their normal diet, the growth of tumor<sup>8</sup> was inhibited by 40% (Nanba *et al.*, 1987). When shiitake content was increased to 30%, tumor growth was inhibited by nearly 78%. When shiitake-supplemented feed (20%) was given a week after and on the same day of tumor implantation, the tumor inhibition rates were 53.9% and 72.4%, respectively. In a 1969 study by Dr. Chihara, the growth of Sarcoma 180 was inhibited by 67-81%, when aqueous shiitake extracts were injected or powdered dried shiitake was fed.

Lentinan is a most frequently studied substance due to its strong anti-tumor effects. Dr. Chihara (1970) found that when doses of 0.5-1mg lentinan per kg of body weight were administered to laboratory mice, Sarcoma 180 regressed or disappeared in 80-100% of the subjects. This purified polysaccharide has been shown to be non-toxic and enhance the immune response, inhibiting the growth of tumors<sup>9</sup> in animal studies.

Besides lentinan, various polysaccharides extracted from *L. edodes* showed anti-tumor and immunostimulating activities. Ikekawa *et al.* (1969) found that an intraperitoneal<sup>10</sup> injection of the freeze-dried water extract of shiitake (200mg/kg/day, for 10 days) produced an 80.7% tumor inhibition rate. Fuji *et al.* (1978) isolated a polysaccharide containing an  $\alpha$ -mannan-peptide complex (KS-2) that strongly inhibited tumor growth when administered to mice both orally and intraperitoneally in doses between 1 and 100mg per kg of body weight.

## Human clinical studies

Cancer patients suffer from severe side effects associated with cancer chemotherapy, as well as cancer. In clinical trials, when lentinan was administered to cancer patients during chemotherapy, tumor growth was inhibited, the effectiveness of chemotherapy was improved and patients' life spans were prolonged. In Japan, lentinan is approved for use as a drug to prolong the lives of patients undergoing chemotherapy for stomach cancer.

Lentinan was shown to increase the survival time for 3 patients with inoperable gastric cancer (Mashiko *et al.*, 1992; Shimizu *et al.*, 1981), and of women with recurrent breast cancer who have undergone surgical therapy (Kosaka *et al.*, 1985). In a randomized controlled trial, 275 patients with advanced or recurrent gastric cancer were given either one of two kinds of chemotherapy<sup>11</sup> alone or with lentinan injections. Statistically, the best results were obtained when lentinan was administered prior to chemotherapy (Taguchi *et al.*, 1981). In another group of 16 patients with advanced cancer, lentinan (4mg/week for 4 weeks) was injected into malignant peritoneal and/or pleural effusions<sup>12</sup>. Eighty percent of the lesions showed clinical responses, and performance status<sup>13</sup> was improved in 7 patients. The survival time for patients who responded immunologically to the treatment was 129 days and 49 days for those who did not respond (Oka *et al.*, 1992).

Researchers found lentinan produces its biological effects, including anti-tumor effects, anti-bacterial effects (tuberculosis) and anti-viral effects (HIV), not by attacking cancer cells, bacteria or viruses directly, but activating different immune responses in the host. Aoki *et al.* identified lentinan's immunostimulating effects in animal and human systems *in vitro*<sup>14</sup> and *in vivo*<sup>15</sup>. Since the immune mechanisms behind various types of cancer are so complex and that highly purified substances are not subject to all situations or individuals, shiitake's immune system strengthening effects in animals and humans are briefly listed in Table 2.

<sup>8</sup> Sarcoma 180 and MM-46. They are murine tumors.

<sup>9</sup> Sarcoma 180 (Maeda *et al.*, 1974b; Togami *et al.*, 1982), ascites hepatoma 134 (Moriyama *et al.*, 1981), and Ehrlich carcinoma (Ying *et al.*, 1987)

<sup>10</sup> administered by entering the peritoneum. Peritoneum is the serous membrane that lines the walls of the abdominal cavity and folds inward to enclose the viscera.

<sup>11</sup> mitomycin C with 5-fluorouracil or tegafur

<sup>12</sup> peritoneal/pleural effusion: an abnormal accumulation of fluid in the peritoneal and pleural space. Pleuron is the thin serous membrane that envelops each lung and folds back to make a lining for the chest cavity.

<sup>13</sup> performance status: one of the indicators doctors use for assessing how a patient's disease is progressing and how the disease affects the daily living abilities of the patient and for determining appropriate treatment and prognosis

<sup>14</sup> *in vitro*: in an artificial environment outside the living organism

<sup>15</sup> *in vivo*: within a living organism

**Table 2.** Immune effects of lentinan *in vitro* and *in vivo* in animals and humans

Activity	Experimental Animal System		Human System	
	<i>in vitro</i>	<i>in vivo</i>	<i>in vitro</i>	<i>in vivo</i>
Humoral Factors				
Inhibition of immunosuppressive substance production	-	++	-	++
Immunopotentiative substance production	-	++	-	++
C3 splitting activity	-	+	-	-
Antibody production	-	+	-	+
Opsonin production	-	-	-	+
Production of colony-stimulating factor	+	-	-	-
Production of lymphocyte-activating factor (IL-1)	+	+	+	+
Inhibition of prostaglandin release	-	+	-	-
Interferon production	-(?)	+	-±	-
Cellular Factors				
Natural killer cell activation	+	+	±~+	++
Activation of helper T-cells	-	+	+	++
Activation of killer T-cells	+	+	+	-
Activation of cytotoxic macrophages	-	+	-	+
Delayed-type hypersensitivity reaction	+	+~++	-	-
Mitogenicity	-	-	±~+	++

Sources: Aoki, 1984a,b; Takeshita *et al.*, 1993; Maeda *et al.*, 1974a; Tani *et al.*, 1992, 1993; Sendo *et al.*, 1981; Miyakoshi and Aoki, 1984a,b; Arinaga *et al.*, 1992; Fujimoto *et al.*, 1992; Sakamaki *et al.*, 1993.

### Anti-viral effects

HIV / AIDS still remains as one of the greatest challenges of the modern medicine. Strong anti-viral activities of lentinan and LEM have drawn great attention in the medical community. LEM seems to be the stronger of the two. The major viral diseases studied in associated with anti-viral effects of *L. edodes* are Hepatitis B and HIV.

### Animal tests

Lentinan has shown anti-viral activity in mice against viruses and virus-induced tumors<sup>16</sup>. Lentinan could also stimulate non-specific resistance against respiratory viral infections in mice. Notable protection was induced by lentinan administered through the nose before lethal influenza virus infection which could be confirmed by a reduction of the lung virus titres<sup>17</sup>. Lentinan also conferred complete protection against an LD75<sup>18</sup> challenge dose of virulent influenza virus, and significantly prolonged the survival time in mice after an LD100 challenge administered through a vein.

### Human clinical studies

Lentinan was successful in treating an HIV-infected patient with low helper-T cell and low lymphocyte counts and low NK cell activity. A drip infusion of lentinan restored these immune cell counts to normal (Aoki, 1984a). Lentinan is particularly active at augmenting helper-T cell activity (Akiyama *et al.*, 1981) and thus, assists HIV treatment.

LEM may also be useful in the treatment of AIDS. It has been shown to inhibit HIV infection of cultured human T-cells (Izuka, 1990), and it potentiates the effects of AZT (one of anti-HIV medications) against viral replication *in vitro* (Tochikura *et al.*, 1987). The mechanism of its action is not known for certain, but the extract was found to activate macrophages and stimulate the production of interleukin-1.

In addition to lentinan and LEM, water-soluble lignins with anti-viral and immunomodulating effects have also been isolated from shiitake mycelium (Hanafusa *et al.*, 1990). JLS, a new compound recently derived from the mycelium, showed the ability to block the release of infectious *Herpes simplex* virus type I in animals (Sarkar *et al.*, 1993). Shiitake contains water-solubilized lignin derivatives, such as EPS and EPS4, which have shown immunological and anti-viral activities not

<sup>16</sup> VSV (vesicular stomatitis virus)-encephalitis, Abelson (Chang, 1981), and adenovirus type 12 virus-induced tumors (Hamada, 1981)

<sup>17</sup> titer: concentration of a substance in solution or the strength of such a substance determined by adding to it a standard reagent of known concentration in carefully measured amounts until a reaction of definite and known proportion is completed

<sup>18</sup> LD: lethal dose. LD 75 is the amount of drug it takes to kill 75% of the subject group.

only against *Herpes simplex* I and II, but also against equine encephalitis, polio virus, measles, mumps, and HIV (Suzuki *et al.*, 1989, 1990; Sorimachi *et al.*, 1990). In addition, an aqueous extract of the mycelium (known as JLS-18), consisting of 65-75% lignin, 15-30% polysaccharide, and 10-20% protein, inhibited the *Herpes* virus both *in vitro* and *in vivo* (Koga *et al.*, 1991).

Even for healthy folks, there are benefits in eating mushrooms. *The Star*, a Malaysian daily newspaper, reported on a pilot study by the National University of Singapore. The study showed that people who ate about 30g of shiitake mushrooms a day for four weeks were less susceptible to flu symptoms during the flu season in Singapore (*The Star*, October 30, 2000).

### Anti-bacterial effects

Active compounds isolated from shiitake have shown potent anti-bacterial activities. Among them, lentinan is the most frequently studied compound as a promising anti-bacterial agent.

#### Animal tests

Lentinan is also effective against tuberculosis infections in the lungs of mice (Kanai and Kondo, 1981). It increased host resistance to infection with the potentially lethal *Listeria monocytogenes*<sup>19</sup> (Aoki, 1984b).

Lentinan may afford protection against toxic stress from bacterial endotoxin<sup>20</sup>. For instance, when lentinan was administered to rabbits with endotoxin, its clearance was increased (Yokota *et al.*, 1991).

#### Human clinical studies

For instance, in a study of 3 patients with pulmonary tuberculosis who had shed drug resistant *M. tuberculosis*<sup>21</sup> bacteria for 10 years, after treatment with lentinan, the excretion of *M. tuberculosis* ceased (Usuda, 1981). These findings have been supported by several animal studies (Kanai and Kondo, 1981; Kanai *et al.*, 1980).

### Hepatoprotective effects

#### Animal tests

Sugano *et al.* noted in their 1982 study that the injection of LEM slowed the growth of cancerous liver tumors in rats. Studies by Lin and Huang (1987) and Mizoguchi *et al.* (1987) also observed that polysaccharide fractions from shiitake demonstrated liver-protective action in animals.

#### Human clinical studies

In an unrandomized, uncontrolled clinical study by Dr. Amagase (1987), 40 patients with chronic hepatitis orally took 6g of LEM per day for 4 months. Hepatitis B symptoms were alleviated in all of the patients, and the virus was inactivated.

### Cardiovascular effects

One unique amino acid, called eritadenine, is believed responsible for shiitake's ability to reduce cholesterol and lipids in blood (Yamamura and Cochran, 1974).

#### Animal tests

In a 1996 study, Dr. Kaneda found that blood serum cholesterol in lab mice was lowered by injection of hot water extract of shiitake. When eritadenine (0.005%) was added to the diet of rats, total cholesterol level was lowered by 25% in as little as one week (Chibata *et al.*, 1969). The cholesterol-lowering activity of eritadenine was more remarkable in rats on a high-fat diet than in those on a low-fat diet (Rokujo *et al.*, 1969). Eritadenine was found to accelerate cholesterol metabolism and excretion. It is highly expected as a potential anti-high blood pressure agent.

#### Human clinical studies

In a 1974 study by Suzuki and Oshima, 10 young Japanese women showed a decrease in serum cholesterol of 7% after one week on dried shiitake (9g). Another group who ate 90g of fresh shiitake showed a 12% drop in serum cholesterol after 7 days. A further study in young women on fresh shiitake (90g) for a week included butter (60g) in addition to the shiitake. In a control group of 10 women, only the butter was added to the diet for one week. In this group serum cholesterol showed a 14% increase, whereas the group on the shiitake and the butter showed a 4% decrease. A separate study found that people in their sixties or older showed a 9% drop in cholesterol, whether they took dried or fresh shiitake.

<sup>19</sup> *Listeria monocytogenes*: a disease-causing bacterium that is food borne and causes an illness called listeriosis

<sup>20</sup> endotoxin: toxin produced by certain bacteria and released upon destruction of the bacterial cell

<sup>21</sup> *Mycobacterium tuberculosis*: a bacterium causing tuberculosis in human

### Toxicity and side effects

*L. edodes* is non-poisonous and safe, though some people may experience minor side effects or allergic reactions. Most common cases are shiitake dermatitis or diarrhea. They are associated with consumption of half-cooked or raw shiitake. During 17 years researchers have observed numerous cases of shiitake-induced dermatitis (Nakamura and Kobayashi, 1985; Ueda *et al.*, 1992). Nakamura (1992) reviewed the clinical manifestations, laboratory findings, and sources of shiitake dermatitis. It is known that people who work indoors in the cultivation of shiitake are prone to an immune reaction to spores called "mushroom worker's lung." Antibodies to shiitake spore antigens can be demonstrated in people who show symptoms. Protective masks can help, but not entirely eliminate, an eventual reaction to the spores after continued exposure (Van Loon, 1992).

A watery extract of the whole fruiting body is reported to lessen the effectiveness of the blood platelets in the process of coagulation, so people who bleed easily or who are taking blood thinners should use caution when chronically using shiitake or its water-soluble fractions (Yang and Jong, 1989).

In a phase I clinical trial of 50 patients with advanced cancer, 0.5-50mg/person/day lentinan was given by injection for 2 weeks. Minor side effects such as a slight increase in GOT and GPT liver enzymes<sup>22</sup> and a feeling of mild oppression on the chest were caused at 5mg/day, but these disappeared after lentinan administration was stopped.

In a phase II trial, only 17 of 185 patients with advanced cancer had similar transitory side effects. Skin eruptions were noted in 7 cases, mild oppression on the chest, 6 cases, and mild liver dysfunction, 4 cases (Taguchi *et al.*, 1982).

In a follow-up phase III trial by the same researchers, 15 out of 275 patients experienced nausea and vomiting (2), heaviness in the chest (4), heat sensations (2), and one case each of face flushing, a rise in blood pressure, and heaviness in the head (Taguchi *et al.*, 1981b; Aoki, 1984b). Lentinan seems to be very safe when given to humans in the dosage range of 1-5mg/day once or twice a week by intravenous injection (Taguchi *et al.*, 1982).



**Figure 9.** Shiitake in everyday use **A:** Mushroom as stew ingredients **B:** Mushroom-flavored noodle **C:** Mushroom powder  
**D:** Mushroom-flavored biscuit **E:** Mushroom chips

<sup>22</sup> GOT: glutamine-oxaloacetic transaminase, GPT: glutamic-pyruvic transaminase. These liver enzymes are elevated for a variety of reasons. They are checked for suspected liver disease, also for suspected mononucleosis, or to monitor the effect of long term drug therapy on the liver.

Shiitake is used medicinally for diseases involving depressed immune function, including cancer, AIDS, environmental allergies, and frequent flu and colds. It also appears beneficial for soothing bronchial inflammation and regulating urine incontinence (Liu and Bau, 1980), as well as for reducing chronic high cholesterol. According to one prominent Japanese researcher, lentinan is an immunomodulating agent. For older persons, it serves as a general rejuvenating agent, no matter what the condition of their health. For young people, it presents a potent protection from overwork and exhaustion (Aoki, 1984b) or chronic fatigue syndrome. In Japan, lentinan is currently classified as a drug, whereas LEM is considered a food supplement.

As more clinical research on shiitake and preparations isolated from shiitake is published, the effective range of application will be more broadened. But the highly purified compounds including lentinan and LEM are subject to a particular situation or individual. Addition of shiitake to a daily diet is highly recommended to maintain good nutrition, to boost the immune system and to prevent various diseases. Shiitake containing almost all essential amino acids will serve as an excellent protein supplement.

## REFERENCES

- Akiyama, Y. *et al.* 1981. Immunological characteristics of anti-tumor polysaccharides lentinan and its analogues, as immune adjuvants. In: Aoki, T. *et al.*, eds: *Manipulation of Host Defense Mechanisms*. Amsterdam, the Netherlands: Excerpta Medica. International Congress Series 576.
- Amagase, H. 1987. Treatment of hepatitis B patients with *Lentinus edodes* mycelium. In: *Proceedings of the 12<sup>th</sup> International Congress of Gastroenterology*. Lisbon. pp. 197.
- Aoki, T. 1984a. Antibodies to HTLV-1 and HTLV-2 in sera from two Japanese patients, one with possible pre-AIDS. *Lancet* 20: 936-937.
- Aoki, T. 1984b. Lentinan. In: Femchel, R.L. and M.A. Chirgis, eds: *Immunology Studies: Immune Modulation Agents and Their Mechanisms* 25: 62-77.
- Arinaga, S. *et al.* 1992. Enhanced production of interleukin-1 and tumor necrosis factor by peripheral monocytes after lentinan administration in patients with gastric carcinoma. *International Journal of Immunopharmacology* 14: 43-47.
- Chibata, I. *et al.* 1969. Lentinacin: A new hypocholesterolemic substance in *Lentinus edodes*. *Experientia* 25: 1237-1238.
- Chihara, G. *et al.* 1969. Inhibition of mouse Sarcoma 180 by polysaccharides from *Lentinus edodes* (Berk.) Sing. *Nature* 222: 631-688.
- Chihara, G. *et al.* 1970. Fractionation and purification of the polysaccharides with marked antitumor activity, especially lentinan, from *Lentinus edodes* (Berk.) Sing. (an edible mushroom). *Cancer Research* 30: 2776-2781.
- Fujimoto, T. *et al.* 1992. Evaluation of basic procedures for adoptive immunotherapy for gastric cancer. *Biotherapy* 5: 153-163.
- Hahafusa, T. *et al.* 1990. Intestinal absorption and tissue distribution of immunoactive and antiviral water-soluble [14C] lignins in rats. *Yakubutsu Dotai* 5: 661-674.
- Izuka, H. 1997. Production of *Lentinus edodes* mycelia extract (LEM). *Food Reviews International* 13: 343-348.
- Izuka, C. 1990. Antiviral composition extracts from basidiomycetes. *European Patent Application EP 464,311*. In: CA, 116: 76351z.
- Kanai, K., and E. Kendo. 1981. Immunomodulating activity of lentinan as demonstrated by frequency limitation effect on post-chemotherapy relapse in experimental mouse tuberculosis. In: Aoki, T. *et al.*, eds: *Manipulation of Host Defense Mechanisms*. Amsterdam, the Netherlands: Excerpta Medica. International Congress Series 576.
- Kiribuchi, T. 1991. Effective uses of fungi by UV irradiation. 3. Change of free amino acid composition in fungi by sulfolite or ultraviolet light irradiation. *Nippon Kasei Gakkaiishi*, 42,415-421. In: CA, 115: 130700g.
- Koga, J. *et al.* 1991. Antiviral fraction of aqueous *Lentinula edodes* extract. *European Patent Application EP 437,346* (Cl. 012pa/02), *JP Application 90/3,818*. In: CA, 115: 134197w.
- Kosaka, A. *et al.* 1985. Synergistic effect of lentinan and surgical endocrine therapy on the growth of DMBA-induced mammary tumors of rats and of recurrent human breast cancer. *Int J Cancer* 69,138-150. In: CA, 104: 81628b.
- Lasota, W., and J. Sylwestrzak. 1989. Chemical composition of cultivated mushrooms. Part III. Shiitake *Lentinus edodes* (Berk.) Sing. *Bromatol Chem Toksykol.* 22: 167-171. In: CA, 114,205741m.
- Lin Z. and Huang Y. 1987. Protective action of Lentinan against experimental liver injuries. *J. Beijing Med. Univ.* 19: 93-95.
- Liu, B. and Y.-S. Bau Y. 1980. *Fungi Pharmacopoeia*. CA: Oakland: Kinoko Press.
- Maeda, Y.Y. *et al.* 1974. Unique increase of serum protein components and action of antitumor polysaccharides, *Nature* 252-250.
- Mashiko, H. *et al.* 1992. A case of advanced gastric cancer with liver metastasis completely responding to a combined immunotherapy with UFT, mitomycin C and lentinan. *Gan to Kagaku Ryoho* 19: 715-718.
- Miyakoshi, H., and T. Aoki. 1984a. Acting mechanisms of lentinan in human: I. Augmentation of DNA synthesis and immunoglobulin production of peripheral mononuclear cells. *Journal of Immunopharmacology* 6: 365-371.
- Miyakoshi, H., and T. Aoki. 1984b. Acting mechanisms of lentinan in human: II. Enhancement of non-specific cell-mediated cytotoxicity as an interferon-inducer. *Journal of Immunopharmacology* 6: 373-379.
- Mizoguchi, Y. *et al.* 1987. Protection of liver cells against experimental damage by extract of cultured *Lentinus edodes* mycelia (LEM). *Gastroenterol. Jpn.* 22: 459-464.
- Nakamura, T. 1992. Shiitake (*Lentinus edodes*) dermatitis. *Contact Dermatitis* 27: 65-70.
- Nakamura, T., and A. Kobayashi. 1985. Toxicodermma caused by the edible mushroom shiitake (*Lentinus edodes*). *Hautarzt* 36: 591-593.

- Nanba, H. *et al.* 1987. Antitumor action of shitake (*Lentinus edodes*) fruit bodies orally administered to mice. *Chemical & Pharmaceutical Bulletin* 35: 2453-2458.
- Oka, M. *et al.* 1992. Immunological analysis and clinical effects of intra-abdominal and intrapleural injection of lentinan for malignant ascites and pleural effusion. *Biotherapy* 5: 107-112.
- Rokujo, T. *et al.* 1969. Lentysine: a new hypolipemic agent from a mushroom. *Life Science* 9: 381-385.
- Sakamaki, S. *et al.* 1993. Individual diversity of IL-6 generation by human monocytes with lentinan administration. *International Journal of Immunopharmacology* 15: 751-756.
- Sarkar, S. *et al.* 1993. Antiviral effect of the extract of culture medium of *Lentinus edodes* mycelia on the replication of herpes simplex virus type 1. *Antiviral Research* 20: 293-303.
- Sendo, F. *et al.* 1981. Augmentation of natural cell-mediated cytotoxicity by administration of lentinan in mice. In: Aoki T. *et al.*, eds: *Manipulation of Host Defense Mechanisms*. Amsterdam, the Netherlands: Excerpta Medica. International Congress Series 576.
- Shimizu, T. *et al.* 1981. A combination of regional chemotherapy and systemic immunotherapy for the treatment of inoperable gastric cancer. In: Aoki T. *et al.*, eds: *Manipulation of Host Defense Mechanisms*. Amsterdam, the Netherlands: Excerpta Medica. International Congress Series 576.
- Sorimachi, K. *et al.* 1990. Antiviral activity of water-solubilized lignin derivatives *in vitro*. *Agricultural and Biological Chemistry* 54: 1337-1339. In: CA, 113: 52122n.
- Suzuki, H. *et al.* 1989. Inhibition of the infectivity and cytopathic effect of human immunodeficiency virus by water-soluble lignin in an extract of the culture medium of *Lentinus edodes* mycelia (LEM). *Biochemical and Biophysical Research Communications* 160: 367-373. In: CA, 110: 2051571.
- Taguchi, T. *et al.* 1981. Phase I and II studies of lentinan. In: Aoki, T. *et al.*, eds: *Manipulation of Host Defense Mechanisms*. Amsterdam, the Netherlands: Excerpta Medica. International Congress Series 576.
- Taguchi, T. *et al.* 1982. Clinical trials on lentinan (polysaccharide). In: Yamainura, Y. *et al.*, eds: *Immunomodulation by Microbial Products and Related Synthetic Compounds*. New York: Elsevier. pp.467-475.
- Takeshita, K. *et al.* 1993. Effect of lentinan on lymphocyte subsets of peripheral blood, lymph nodes, and tumor tissues in patients with gastric cancer. *Surgery Today* 23: 125-129.
- Tani, M. *et al.* 1992. *In vitro* generation of activated natural killer cells and cytotoxic macrophages with lentinan. *European Journal of Clinical Pharmacology* 42: 623-627.
- Tani, M. *et al.* 1993. Augmentation of lymphokine-activated killer cell activity by lentinan. *Anticancer Research* 13: 1773-1776.
- Tochikura, T.S. *et al.* 1987. Suppression of human immunodeficiency virus replication by 3-azido-3-deoxythymidine in various human haematopoietic cell lines *in vitro*: augmentation by the effect of lentinan. *Japan Journal of Cancer Research (Gann)* 78: 583.
- Ueda, A. *et al.* 1992. Allergic contact dermatitis in shiitake (*Lentinus edodes* ([Berk.] Sing.) growers. *Contact Dermatitis* 26: 228-233.
- Usuda, Y. *et al.* 1981. Drug-resistant pulmonary tuberculosis treated with lentinan. In: Aoki T. *et al.*, eds: *Manipulation of Host Defense Mechanisms*. Amsterdam, the Netherlands: Excerpta Medica. International Congress Series 576. p. 50.
- Van Loon, P.C. 1992. Mushroom worker's lung: detection of antibodies against Shiitake (*Lentinus edodes*) spore antigens in shiitake workers. *Journal of Occupational Medicine* 34: 1097-1101.
- Yamamura Y., and K.W. Cochran. 1974. Chronic hypocholesterolemic effect of *Lentinus edodes* in mice and absence of effect on scrapie. *Mushroom Science* 13(Part 1): 489-493.
- Yang, Q.Y., and S.C. Jong. 1989. Medicinal mushrooms in China. In: Crabbe K. and O. Hilber, eds: *Mushroom Science* 13(Part I): *Proceedings of the 12<sup>th</sup> International Congress on the Science and Cultivation of Edible Fungi*. Braunschweig, Germany: Institut für Bodenbiologie, Bundesforschungsanstalt für Landwirtschaft. pp. 631-643.
- Yokota, M. *et al.* 1991. Endotoxemia is masked in fungal infection due to enhanced endotoxin clearance by beta-glucan. *International Surgery* 76: 255-260.

## Part I Shiitake

### Chapter 1

### What is Shiitake

## ILLUSTRATED GUIDE TO SHIITAKE CULTIVATION

Byung Sik Kim (Steve)

MushWorld, 150-5 Pyungchang, Jongro, Seoul, Korea (bskim@mushworld.com)

Illustrated by Seung Wan Moon of Heineart Inc., Korea



Mushrooms are cultivated at farms or harvested in nature. They are sold at markets.



"Excuse me. Is this mushroom? I want to know how to grow mushrooms."



"It's shiitake and cultivated at a farm. There are two ways to cultivate shiitake. Are you ready to learn how to grow shiitake?"



#### Log Cultivation

The log cultivation method is the most well-known and traditional one. High quality shiitake grows on the healthy oak logs. First of all, fell hardwood trees at dormant season.



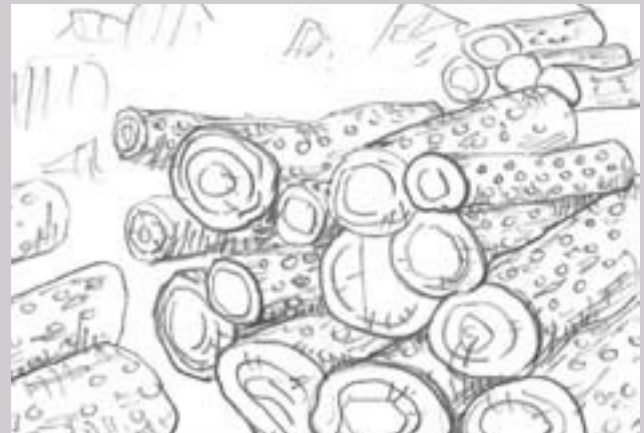
Cut the felled logs about 1-1.2m long.



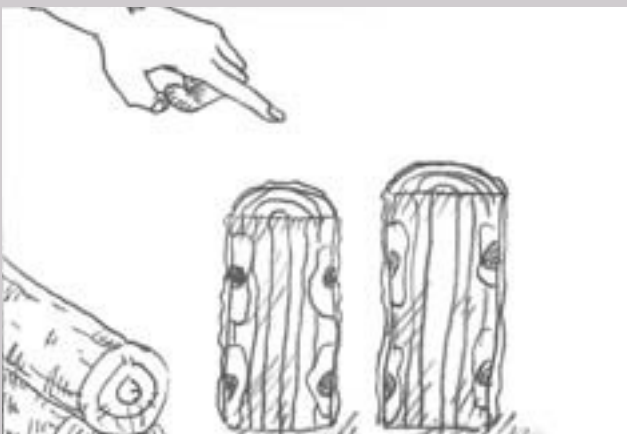
Inoculation holes are drilled in the logs at 15-20cm intervals from 5cm apart from the end of the logs. Holes are 2.5cm deep and 1.2cm wide with row 3-4cm apart.



Put the sawdust plug spawn into holes. Styrofoam seal is attached to the plug spawn to prevent contamination.



Stack the inoculated logs 1m high for 1-2 months as you would do fire-wood.



When mycelia colonize around inoculation holes to a certain degree during spawn run, stack the logs again and let shiitake mycelia spread over the logs.



Standing logs (A-frame stacking) aid the development of fruiting bodies.



Usually watering induces fruiting from the logs. But some growers provide physical shock by beating logs.



Fruitbodies of shiitake grown on the log

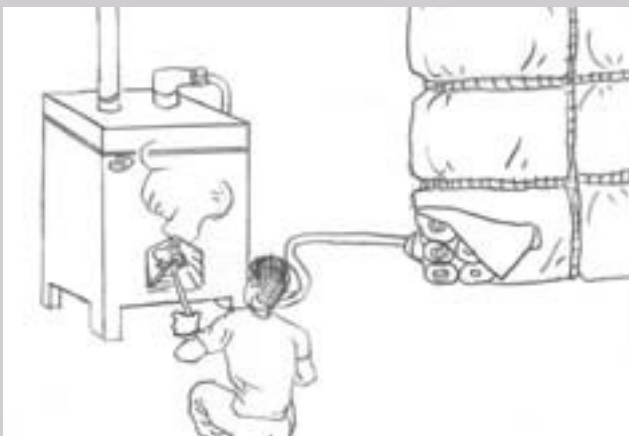
**Bag Cultivation**



Sawdust is usually selected as main ingredients and supplemented by wheat bran or rice bran, gypsum, calcium and so on.



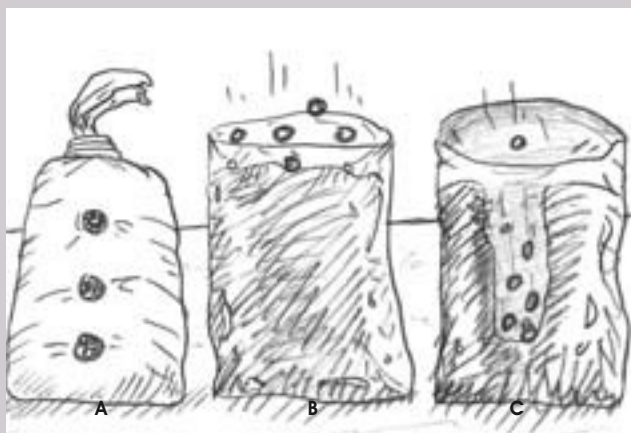
All materials are mixed with water and put it into bags. Polyethylene bags are usually used to contain raw materials.



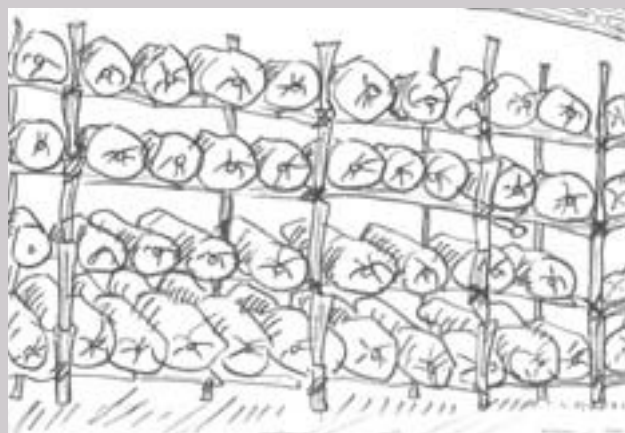
Sterilization depends on the nature of the bags, bag size and amount of the substrate. 2-3kg sawdust substrate is sterilized in an autoclave for one and half hour at 121 °C.



When the bags cool down to room temperature, they are ready to be inoculated in the inoculation room or disinfected room.



A: Make holes with the sterilized stick on the bag, put the spawn into them and seal them with tape.  
 B: Scatter spawns on the top of the substrate.  
 C: Make a vertical hole in the middle of substrate in the bag and put spawn into it.



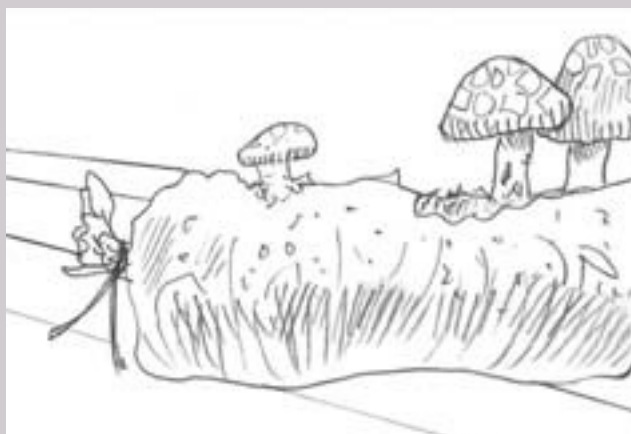
Most shiitake strains show optimal mycelial growth at 25°C, 60-70% R.H.. No light is necessary during spawn run. The duration of spawn run is usually 3 months.



Watering is commonly used for fruiting induction after brown-ing.



Growers make the cuts at the pinning spots on the plastic bag to help the fruiting bodies come out.



Shiitake fruiting bodies on the bag



Harvested shiitake are sold fresh or dried in wholesale and retail markets.



"Sounds interesting! I want to give a try. Where can I learn more of shiitake growing?"



If you want to cultivate shiitake, you might want to learn the technology of mushroom cultivation from a training center or your neighbors who grow shiitake.

## Part I Shiitake

## Chapter 2

Shiitake Spawn and Strain**SHIITAKE SPAWN PREPARATION CHIEFLY WITH SAWDUST**

Seungwoo Kang (Richard)

MushWorld, 150-5 Pyungchang, Jongro, Seoul, Korea (swkang@mushworld.com)

**Introduction****Common characteristics**

Shiitake, *Lentinula edodes*, is a saprophyte and white rot fungus which feeds on dead oak tree species in nature. In its life cycle, each basidium under the gill of a fruitbody produces four basidiospores which sporulate under a certain condition to become a primary mycelium and then a secondary mycelium by fusion between compatible mycelia. Shiitake spawn is a medium, colonized by the secondary mycelia. The secondary mycelia will eventually form fruitbodies.

Factors regarding mycelial growth are shown in the table below.

**Table 1.** Spawn run parameters of shiitake and others

	<i>Lentinula edodes</i>	<i>Coprinus comatus</i>	<i>Pleurotus ostreatus</i>	<i>Volvariella volvacea</i>	<i>Ganoderma lucidum</i>
Temperature (°C)	21-27	21-27	24	24-35	21-27
R.H. (%)	95-100	95-100	85-95	80-95	95-100
Duration (days)	35-70	12-14	12-21	5-10	10-20
CO <sub>2</sub> (ppm)	> 10,000	5,000-20,000	5,000-20,000	> 5,000	< 50,000
Fresh air exchange	0-1 / hour	0-1 / hour	1 / hour	1	0-1 / hour
Light (lux)	50-100	n/a	n/a	No light	n/a

Source: Paul Stamets, 2000

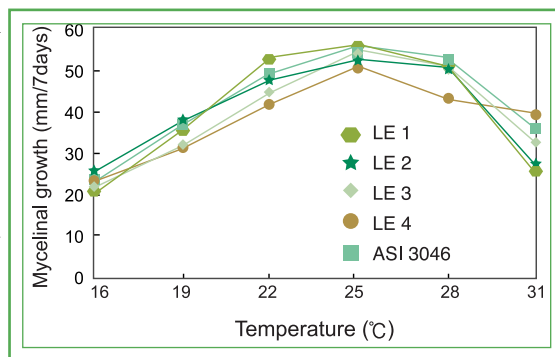
**Classification****Strain categorized by fruiting temperature**

Shiitake strains are classified into three kinds by fruiting temperature: high, mid and low temperature strains. Strains fruiting best at  $15 \pm 5^\circ\text{C}$  belong to mid-temp. strain range; lower than that are called a low-temp. strain; strains fruiting at higher temperatures are called a high-temp. strain. Optimum incubation temperature for all strains is around  $25^\circ\text{C}$  (Fig. 1). It is reasonable for a grower to have an assortment of 2-3 strains.

- 1) Low-temperature (cold-weather) strains usually grow slowly and produce thick-fleshed big caps. In cold areas where the climate is not good for mass production, growers can rather produce high quality shiitake by growing low-temp. strain shiitake on logs. In log cultivation, it takes long time for incubation, from 16 to 20 months. However, logs may produce fruitbodies for four or more years, much longer than substrate bags.
- 2) High-temperature (warm-weather) strains grow fast, are easily browned, but produce thin-fleshed small caps. Under

the warm climate, growers can combine high-temp. strains with the bag cultivation method to shorten the production period and compete well in terms of producing amount. In case of bag cultivation, these warm strains require 1-2 months for the spawn run and will produce for several months after production begins.

- 3) With wide-temperature (all-weather, wide-range) strains, incubation takes nearly the same time as warm-weather strains. They can be grown at a wide range of temperatures and they can be good choice to beginning shiitake growers. In case of log cultivation, with the wide-range strain, spring inoculation may produce the following fall and fall spawning may produce the following spring. Logs are expected to produce fruitbodies for 3-4 years after pinning. The production period depends on substrate material, log size, spawn type, climate, management and so forth (D. B. Hill, 2002).



**Figure 1.** Mycelial growth of *Lentinula edodes* PDA medium for 7 days after inoculation. Fruiting temperature: LE1 (16-24 °C, mid-high), LE2 (18-20 °C, mid), LE3 (14-24 °C, mid-high), LE4 (5-16 °C, mid-low), ASI3046 (10-25 °C, mid-high) (Hongkyu Kim, 1999)

### Spawn types by spawn media

Sawdust from various trees, grains, woods, and other agricultural by-products can be used for preparing shiitake spawn media. J. Poppe (2000) reported several research results showing a variety of substrate materials for suitable shiitake spawn, including hammer-milled corncobs (Chang and Miles, 1989); cottonseed hulls (Chang and Miles, 1989); peanut hulls (Chang and Miles, 1989); sawdust with rice bran as additive (Singer, 1961); and sawdust, mixed with rice bran (Singer, 1961). A spawn maker has the choice of at least thirty kinds of sawdust but some sawdust is not digested as well by the mushroom enzymes. In general, the broad-leaved trees deliver the best sawdust for shiitake spawn. In very exceptional cases, lubricant oil from chain saw can disturb the mycelial growth (Chang and Miles, 1989; Poppe, 1995). Tea leaves have also been used as a spawn substrate in Asia, mostly when mixed with grains or cotton waste (Chang and Miles, 1989). Wheat bran is also used as an additive for sawdust based spawn (Chang and Miles, 1989).

- 1) Dowels (wood plugs): Dowels, made of hard wood, are resistant to dry conditions and can be stored longer than sawdust spawn. They are easy and fast to use when inoculating as the farmer needs only hammer them or push to insert them into the inoculation holes and then seal.
- 2) Sawdust spawn: Being composed of small sawdust particles, it has a larger surface area than the same volume of dowels. Sawdust spawn incubates quickly, and can also dry out quickly unless proper conditions are maintained. In case of log cultivation, a spawning tool and sealing wax are required for performing inoculation. Some modern spawning machines use compressed air to insert the spawn into the hole and cover the hole with a styrofoam cap at the same time. In case of bag cultivation, a farmer cuts a piece of the spawn mass and puts it into the inoculation hole. Like a wood dowel, sawdust spawn can be made into sawdust plugs (thimbles). They have the merits of both dowels and sawdust spawns. Thimbles are easy to use and colonize substrate well. However, they are more expensive than the other spawn types. They also dry easily unless stored properly, and should be used as soon as they arrive (D. B. Hill, 2002).
- 3) Grain spawn: It is used for bag cultivation. This spawn may attract rodents, but is easier to handle than sawdust spawn.

### How to Make Spawn

Shiitake spawn can be made using high quality fresh shiitake or wild picked specimens as the inoculum. A fruitbody is cut into two pieces vertically, and then a small piece is taken from a cut surface of the fruitbody and transferred to PDA media. This is then incubated. Though some growers certainly make their own spawn by themselves using this method, the development of a pure, high quality strain needs sophisticated equipment, time and money. It is, therefore, recommended to buy the desired strains from reliable sources.

The starting point for most spawn producers is the acquisition of a test tube containing strain from an institution such as universities or extension centers where the strains are developed and maintained. They will then transfer the strain to PDA medium in petri dishes. After multiplying the culture by repeating the process several times, they will incubate strain among a spawn substrate such as sawdust, wood plugs or grains. When they acquire sufficient quantities, the spawn is ready for distribution. There are commonly five generations of the spawn, they being the F1 (strain in tubes), the F2, F3, F4 (strain in petri dishes or spawn bottles), and the F5 (spawn in spawn substrate).

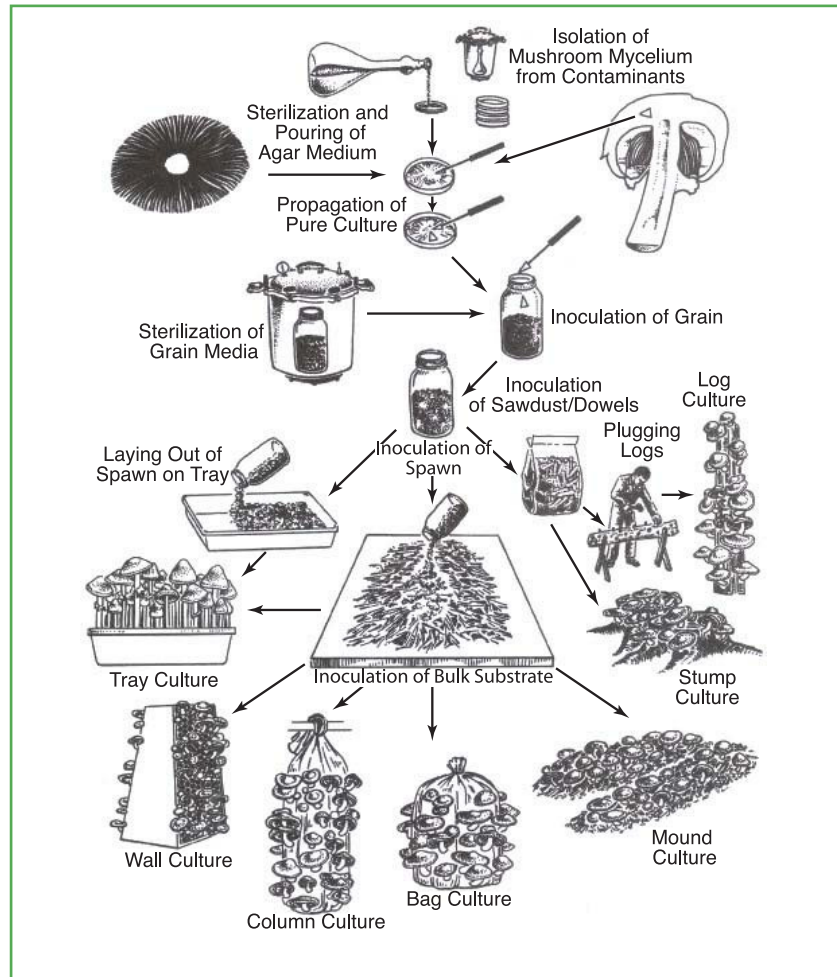


Figure 2. Overview of techniques for growing mushrooms (Paul Stamets, 2000)

### Mycelial transfer from PDA in tube (strain) to PDA in petri dish

#### Materials

- Strain (mother culture in tube)
- 500 ml PDA media: 1,000 ml distilled water, potatoes, 10g agar, and 10g sugar
- Clean bench equipped with air filter, alcohol lamp, petri dishes, transferring tools, 70-75% alcohol (ethanol) and UV lamp
- Autoclave, glass jars, scale, tin foil, incubator and etc.

#### Preparation of PDA media (500 ml)

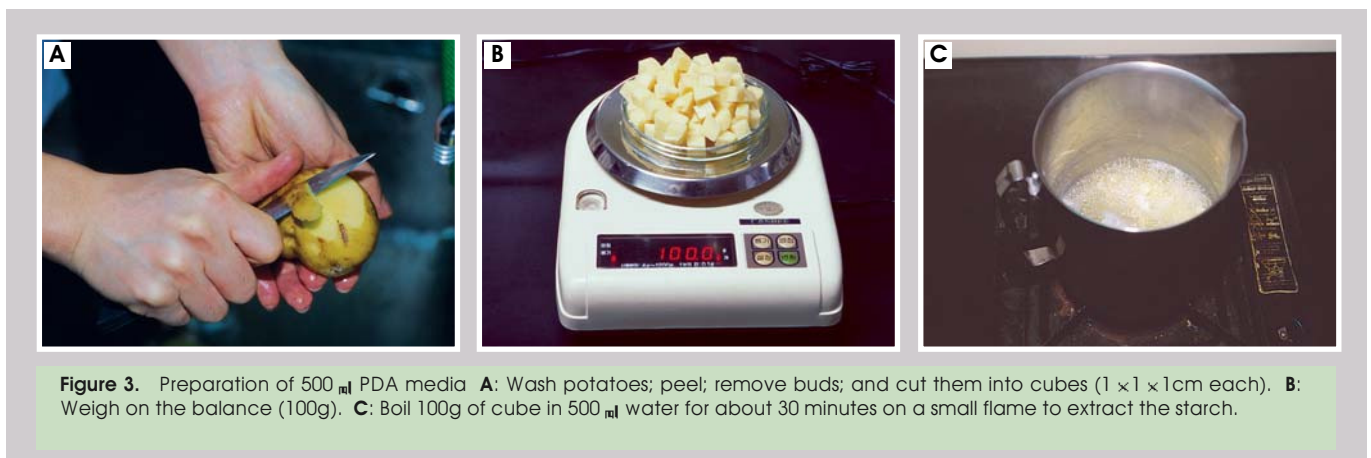


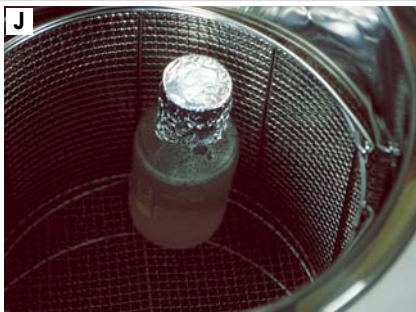
Figure 3. Preparation of 500 ml PDA media **A:** Wash potatoes; peel; remove buds; and cut them into cubes (1 × 1 × 1cm each). **B:** Weigh on the balance (100g). **C:** Boil 100g of cube in 500 ml water for about 30 minutes on a small flame to extract the starch.



**D:** During boiling, prepare exactly 10g agar and 10g sugar for 500<sub>ml</sub> PDA media. **E and F:** Some water vaporizes during boiling. After boiling, add distilled water to make the volume (potato extract water) 500<sub>ml</sub> again.



**G:** Stir well to melt the agar & sugar, and pour the mixed extract into a bottle for autoclaving. **H and I:** Close the jar lightly and cover it with tin foil. The air volume inside the jar is going to decrease during cooling after sterilization; and outside pathogens may invade the jars via the incoming outside air. Tin foil is to keep out contamination.



**J:** Autoclave the jars at 121 °C for 20 minutes. Time should be measured from the point that the temperature inside the autoclave reaches 121 °C; so, the total autoclaving time takes more than 20 minutes. **K:** Disinfect the clean bench before using by spraying 70-75% alcohol on the clean bench and on the transferring tools. In the hot season when contamination increases, a UV lamp can also be used. Operators should wash their hands with 70-75% alcohol. After autoclaving, let the jars cool down to 65-70 °C on the clean bench. **L:** Place the petri dishes in a column; open them from the bottom one and pour 30-35<sub>ml</sub> of the PDA broth quickly and then let those dishes solidify. By staking the dishes, less water drops will form inside the each petri dish. The agar will solidify at around 45 °C and after it does then dishes are ready to use.

## Transferring



**Figure 4.** Transferring from PDA in tube (strain) to PDA in petri dish **A:** Confirm that the mother culture is good. Before transferring, sterilize the tool until it becomes red-hot in the flame. **B:** One hand grabs tube and the other hand grabs tool; cool the tool by touching it on the media. **C:** Hang the tube mouth on the flame for a while; open the cap with a little finger.



**D:** Cut a sample (2 × 2mm) from the mother culture. Tube mouths and tools are flamed on the alcohol lamp before each opening and action. **E:** Slightly open the petri dish and place the sample to the center of the PDA media; close the cap; wrap up the complete dishes with plastic. **F:** Record the required information such as date and strain name. Immediately after the inoculation the petri dishes are kept at a slightly (2-3 °C) higher temperature for several days. It will quite visible soon whether they are contaminated or not (Hyunjong Kwon, 2002).

### Problems and solutions

Problems which can occur during the above mentioned stages and the solutions to those problems are described in the following table.

**Table 2.** Problems and solutions

Problems	Causes	Solutions
Agar medium is very soft and does not solidify	- Incorrect ratio of agar and liquid - Variation in pH	- Follow the correct ratio - Adjust the pH using HCl or NaOH
Growth of contaminants on the surface of the medium in test tube before inoculation	- Medium has not been properly sterilized - Plug (tube cap) may not be airtight - Incorrect method of pouring medium	- Sterilize at required pressure for required time - Plug the cotton tightly - Pour the medium into clean dry sterilized dish
No growth on transferred mycelial bits/discs	- Use of incorrect medium - Variation in pH - Medium is too hot - Death of mycelial tissues in the bit during transfer	- Use correct medium - Adjust the pH - Pour the medium at a lower temperature - Cool the hot inoculation needle before contact with the tissue
Contaminated mycelial plug / contaminated surface after 2-3 days of transfer	- Inoculation location is not aseptically maintained - Use of contaminated culture	- Laminar flow chamber and clean inoculation chamber may be used for inoculation - Clean pure-culture (without contamination) should be used
Growth of mycelium is very slow and fluffy	- Degenerated or virus infected mycelium - Non viable culture	- Use medium size, first harvested mushrooms for pure culturing - Isolate the mushroom from the tissues at the junction of stipe and the pileus

Source: G. Arjunan *et al*, 1999

### Mycelial transfer from PDA in petri dish to spawn substrate

When enough petri dishes are acquired by repeating the above process several times, they are transferred to spawn substrates.

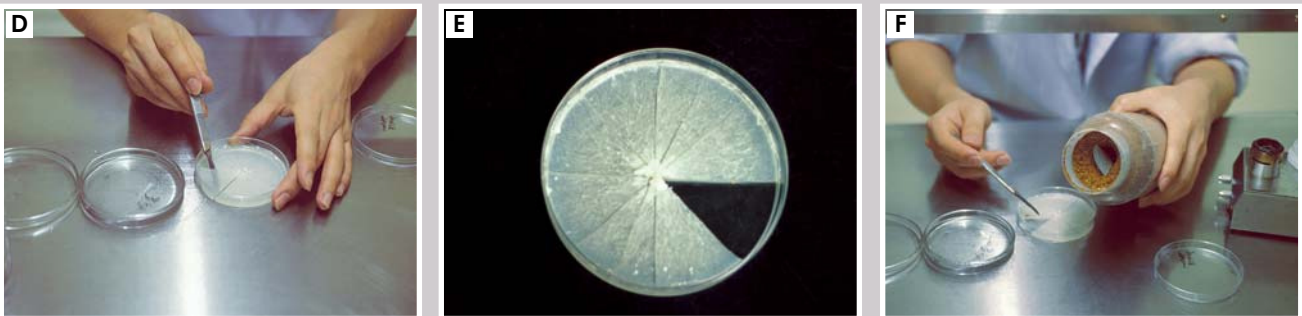
#### Materials

- Mother culture in petri dish
- Substrate materials for shiitake spawn
- Container (spawn bottle), sterilizer (autoclave), mixer and spawning room (clean booth or bench)
- Incubation room with environmental control system is recommended

## Transferring from PDA in petri dish to sawdust

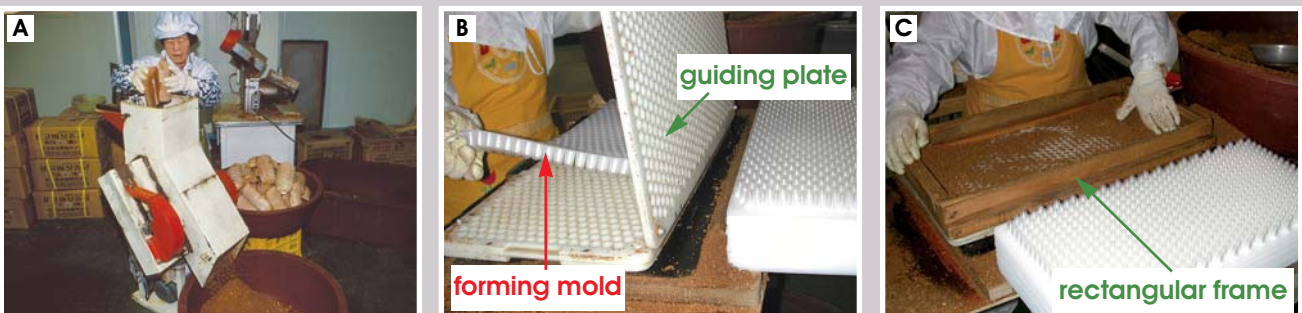


**Figure 5.** Transferring from PDA in petri dish to sawdust **A** and **B**: Fill the heat-resisting spawn containers (bottles, jars or bags) with substrate mixture. 850cc bottle is usually filled with 550cc substrate. Compact the surface of the substrate and make the inoculation hole (1.5-2cm diameter). Close the cap and remove the substrate particles around the bottle mouth. **C**: Sterilize the bags just after filling at 121 °C for 60-90 minutes. Time should be measured from the point that the temperature inside reaches 121 °C; so, the total autoclaving time takes more than 60-90 minutes practically. During sterilization, keep discharging small amount of steam to raise the temperature of substrate evenly. When it goes up to 121 °C inside the substrate, keep the temperature for 60-90 minutes.



**D**, **E** and **F**: After cooling, when the substrate is prepared in the bottles, disinfect the clean bench; transfer the mycelia from incubated mother culture in petri dish above into the inoculation hole of the substrate in the bottles. Record any needed information. Completed spawn is kept at low temperature around 4-5 °C. After two days of spawning, growers should raise them to a normal temperature. When enough quantity is acquired by this multiplication, the bottle contents can be used as sawdust spawn (Hyunjong Kwon, 2002).

## Transferring from sawdust into thimble



**Figure 6.** Transferring from sawdust into thimble **A**: Get rid of plastic bottles and crush sawdust spawn. **B**: Put forming mold between two layers of guiding plate. Guiding plate has many perforations. **C**: Place rectangular frame on the guiding plate and pour crushed spawn into the frame.



**D**: After filling each hole of forming mold with crushed sawdust spawn, remove surplus spawn from the plate. **E**: Place styrofoam on the plate and press to seal each hole of the mold; then remove the guiding plate. **F**: Stack completed forming mold, and move them to incubation room.

### Transferring from PDA in petri dish to grain (by Wanchai Pale, Thailand)

After washing the grains in clean water to remove decayed seeds or dirt, the grains are soaked in clean water for 8 hours at room temperature. Both wheat and sorghum grains can be used, but sorghum is more common. Boil or steam the grains until the grain testae expand and began to crack open. Discard the water and air-dry the steamed grains on clean paper or clean linen cloth.

Fill the clear-flat bottles with the grains to the halfway mark. Close them with cotton plugs, wrap over the plugs with paper. Newspaper is in common due to its low cost. Tie the bottle necks with rubber bands. Plastic bags also can be used as the containers. Sterilize them in an autoclave at 15 psi for 30-40 min and allow the grains to cool. In a transfer chamber, inoculate the cooled grains aseptically with the mycelia from incubated mother culture in petri dish above. It takes about 30 days for the mycelia to fully colonize the grains.



Figure 7. Sorghum spawn A: Incubation B: Fully colonized ones

### Problems and solutions

Table 3. Problems and solutions

Problems	Causes	Solutions
Spawn substrate contaminated after sterilization and before inoculation	- Spawn substrate not completely sterilized - Damaged container	- Proper sterilization for the required period - Remove
Mycelial growth may not develop or continue to the bottom	- Excess moisture in the spawn substrate - Over cooking of spawn substrate	- Add sufficient quantity of CaCO <sub>3</sub> (20g/kg) for proper moisture content of spawn substrate - Adopt a correct sterilization period
Mycelial spread in the spawn substrate is slow	- Spawn substrate too dry - Prevalence of high/low temperature in the room	- Boiling the spawn substrate for specified period - Maintain the required temperature
Irregular mycelial growth in the spawn substrate	- A virus infected culture	- Isolate and use better high yielding culture
Contamination appears on the surface of the spawn substrate / on the mycelial disc	- Contamination during inoculation - Contaminated culture	- Inoculation has to be done in aseptic conditions in a culture room - Use fresh culture free from contaminant
No growth from the mycelial disc on surface layer of spawn substrate	- Dehydrated surface layer - Sterilized bottles or poly-bags not inoculated in time	- Tightly plug the mouth with cotton wool and cover with aluminum paper and tie with a twine - Use the sterilized spawn substrate within 3 days

Source: G. Arjunan *et al.*, 1999

## ■ Spawn Quality

### Maintenance of quality

The criteria for spawn quality are mycelial vigor and the quantity of fruitbodies produced. High quality spawn should also be microbiologically pure and not mixed with other microorganisms and other mushroom strains. The strain should be genetically stable without variation, showing the consistent characteristics of the strain such as color, shape and pinning habit. Mushroom mycelia lose vitality through a series of transfers. Producers should keep the substrate materials clean and meet the sterilization standards. Both cooling and spawning must be done in a clean room. Incubated spawns should be stored in a cool, dark location and shipped in less than a month. Completed spawns should be cultivated at several locations in order to know, when and where any problem has occurred, and to be able to determine whether the problem arose in the spawn production or in the growing process.

### Visual method to select high quality spawns

It is not easy to tell whether the spawn is good or bad by viewing only the outside of the mass. High quality spawn should be fully colonized by thread-like white mycelia that appear highly active and sometimes show a gloss on the surface. There should be no spots caused by other microorganisms and no sour smell. There should be no young fruitbodies growing out of the container.

In contrast, long stored spawn may have a gap between the spawn mass and container wall and may have yellow colored mycelia skins. Yellow or brown water droplets may form inside the container due to an oxygen shortage. Contaminated spawn may have green or orange stains on the surface, a bad, sour smell, and yellowish brown or reddish brown water drops.

### Cultural methods to check apparent contamination of spawn

#### Moist culture

This method uses a moist chamber that provides conditions preferred by the fungi. A transparent plastic jar with a large mouth is filled with clean gauze or a kitchen towel to one third of the height. Enough water is poured to drench the filling materials, and then a dish shaped aluminum foil is put on top of it. Place about 10g of crushed spawn on top of the foil and cap the bottle. Place the bottle where direct sun light can not reach it, and maintain it at 20-30 °C for 3-5 days. Observe the re-growth of the mycelia.

Healthy white spawn will resume their growth and form a white mycelial mass. But, unhealthy spawn will not begin re-growth or, if ever, re-grow very slowly. Mycelia, contaminated by pathogenic fungi such as green mold (green, blue, greenish yellow, bluish green), red bread mold (*Neurospora*, orange, pink) or black mold (black, dark gray), show the specific color of contaminant's spore. And, the mycelia contaminated by bacteria secrete sticky mucous fluid without re-growth.

#### Distilled water culture

This is a still culture (stagnant culture) wherein mycelia are incubated in distilled water. Fill 100ml of distilled water in an Erlenmeyer flask, cap and sterilize it at 121 °C for 15-20 min. After finishing sterilization, cool the flask to 25 °C, put 10g of sawdust spawn inside and incubate it at 25-30 °C for 3-5 days.

In healthy mycelia, a white mycelial colony will float on the clean and transparent water. In fungi contaminated mycelia, specific colored pathogenic spores float on the clear and transparent water. In bacteria infected mycelia, mucous membrane forms on the tainted water. In this test, contamination should be determined by the clarity of water rather than just the color of water, because the water color changes into tan or brown by the fermentation of the sawdust itself (Hyun-wook Lee, 1999).

## ■ Case Study: Mr. Lentinula

Mr. Lentinula, a virtual shiitake grower, hopes to produce 100kg of fresh shiitake every month. He knows how to make his own strain (tissue culture) from shiitake fruitbodies but he decided to acquire a superior strain from an extension service center and brought some strain in tubes, and transferred them into petri dishes. Now, they are almost incubated and seem to ready to make spawn.

<Calculation #1: He produces 100kg shiitake. How much spawn does he need?>

Saying biological efficiency (B.E.) is 50%, 200kg of dry substrate is needed to produce 100kg of fresh shiitake.

$B.E. = \text{fresh weight of mushroom} / \text{dry weight of substrate}$

Assuming water contents of substrate is 65%, 371kg of water will be added to the 200kg dry substrate above.

$\text{water contents} = \text{water} / (\text{dry substrate} + \text{water})$

Then, wet weight of substrate is 571kg.

$\text{wet weight} = \text{dry substrate} + \text{water}$

Saying the inoculation rate is 1.05%, he needs ca. 6kg of shiitake spawn.

$\text{inoculation rate} = \text{spawn} / \text{wet weight of substrate}$

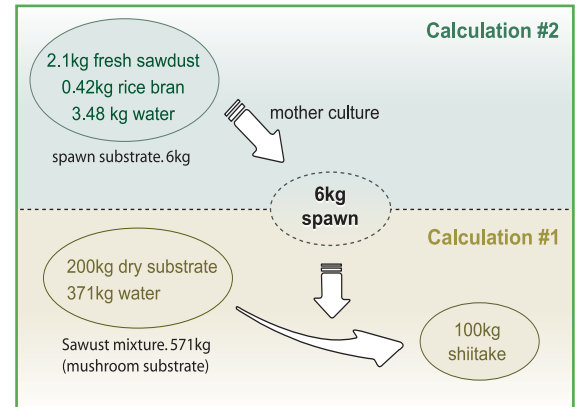


Figure 8. Mr. Lentinula's calculation

<Calculation #2: He needs 6kg spawn. How much each materials does he need?>

As for spawn substrate, Mr. Lentinula uses 80% dry sawdust (main material) and 20% dry rice bran (nutritious supplement); water content is 65%. From the three equations below, now he knows that he needs 3.9kg water, 1.68kg sawdust and 0.42kg rice bran.

$\text{dry sawdust} + \text{rice bran} + \text{water} = 6\text{kg}$

$\text{water} / 6\text{kg} = 0.65$

$\text{dry sawdust} = 4 \times \text{rice bran}$

The supplier told him that water content of fresh sawdust was 20% and the bran was completely dried. Therefore, he ordered 2.1kg fresh sawdust which is 1.68kg dry sawdust & 0.42kg water, and 0.42kg rice bran. Then, already having 0.42kg water in the sawdust, he needs to add only 3.48kg water. Mixing them, he makes 6kg spawn substrate.

## REFERENCES

- Arjunan, G. et al. 1999. *Commercial Production of Spawn and Mushroom*. Department of Crop Protection, ADAC & RI, Tiruchirappalli - 9.
- Bak, Won-chull. 2002. Characteristics of shiitake spawn. *MushWorld*. available at [http://kr.mushworld.com:1507/breeding/view.asp?cata\\_id=2200&vid=4712](http://kr.mushworld.com:1507/breeding/view.asp?cata_id=2200&vid=4712)
- Hill, D. B. 2002. Kentucky Shiitake Production Workbook - Spawn selection (FOR-80). available at <http://www.ca.uky.edu/agc/pubs/for/for80/for80.htm>
- Kim, Hongkyu. 1999. Study on shiitake strain development. Chungcheong Nam-Do Agricultural Research And Extension Services. <http://www.cmongup.net>
- Kwon, Huynjong. 2002. A visual guide for spawn production. *MushWorld*. available at [http://www.mushworld.com:1508/tech/view.asp?cata\\_id=1110&vid=4945](http://www.mushworld.com:1508/tech/view.asp?cata_id=1110&vid=4945)
- Lee, Hyun-wook. 1999. Spawn making and high quality spawn selection. *MushWorld*. available at [http://kr.mushworld.com:1507/breeding/view.asp?vid=1513&cata\\_id=2100](http://kr.mushworld.com:1507/breeding/view.asp?vid=1513&cata_id=2100)
- Poppe, J. Use of agricultural waste materials in the cultivation of mushrooms. *Mushroom Science* 15: 3-23
- Stamets, P. 2000. *Growing Gourmet and Medicinal Mushrooms*. 3<sup>rd</sup> ed. pp. 80.

## Part I Shiitake

## Chapter 2

Shiitake Spawn and Strain**IMPROVEMENT OF SPAWN FOR CULTIVATION  
IN ALTERNATIVE SUBSTRATES**Gerardo Mata<sup>1</sup> and Jean Michel Savoie<sup>2</sup><sup>1</sup>Unidad de Micología, Instituto de Ecología, Apdo. Postal 63, Xalapa 91000, Ver., Mexico (gerardo\_mata2000@yahoo.fr)<sup>2</sup>MYCSA, France**Introduction**

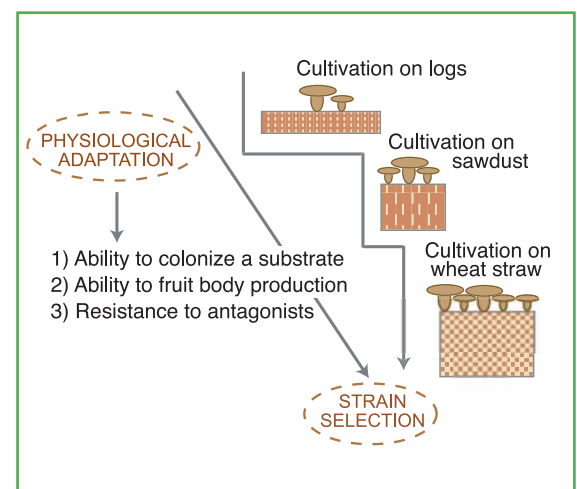
Spawn, frequently called "inoculum," is the vegetative tissue of the fungus and consists of a medium which has been permeated by mycelium. Shiitake spawn commercially prepared on wooden pegs is known as "plugs," on supplemented sawdust called "sawdust spawn" (Przybylowics and Donoghue, 1988; Kozak and Krawczyk, 1989), and recently also produced on cereal grains (Mata *et al.*, 1998). The process of introducing spawn into the substrate is called inoculation or spawning. An adequate spawn is one possessing a mycelium that is capable of rapid growth when invading a particular substrate (Leatham and Griffin, 1984). Shiitake cultivated on sterilized substrates must have a competitive advantage over other colonizers (present in the substrate or introduced without intention at spawning) that might potentially utilize the same space and nutrients.

The use of non conventional substrates for shiitake cultivation is promising for the treatment of agricultural by-products but it implies the preparation of a special spawn that assures an adequate mycelial development on the substrate (Donoghue *et al.*, 1996). In sterilized substrates, there is a risk of contamination at spawning by mould spores or bacteria present in the environment. Generally, competition between shiitake and antagonistic organisms occurs during the first days after spawning. The use of efficient shiitake strains selected specifically for their ability to colonize a non-conventional substrate and the use a vigorous mycelium as spawn could be decisive for substrate colonization and the success of the cultivation. The components used for spawn making play very important roles in mycelium vigor and can reduce the incidence of antagonistic organisms affecting shiitake cultivation (Mata *et al.*, 1998, 2002; Ohmasa and Cheong, 1999; Savoie *et al.*, 2000).

When alternative substrates are used for shiitake cultivation, strains must be selected carefully and their abilities have to be improved by using supplemented spawn (Fig. 1). Information is given to reach these goals through the cases of the development of shiitake cultivation in pasteurized cereal straw or coffee pulp.

**Strain selection**

Strain selection is one of the most important selections in mushroom cultivation. Different strains should be chosen according to other growing parameters and market demand pattern. For example, farmers grow high-temp. strain and low-temp.



**Figure 1.** Factors to consider in shiitake strain selection

strain in turn where they have several seasons. If they have specific mould problems with high density cultivation in some areas, the farmers can use specific strains that resist the pathogen. When stipe consumption increases in the market, farmers will change to a strain that produces mushrooms with long and thick stipes. And when consuming preference shifts from dark to bright, bright-color strain can be chosen.

The capacity of a mushroom to grow on a lignocellulosic substrate is related to the vigor of its mycelium, as well as to its capacity to activate physiological mechanisms necessary to adequately exploit the medium (Buswell *et al.*, 1993). This capacity is defined as its competitive saprophytic ability. This capacity is dictated by the characteristic genetic make-up of each strain and is substrate specific. Competitive saprophytic ability depends on 1) the ability to grow rapidly when stimulated by soluble nutrients and to use an appropriate enzyme system for degradation of resistant constituents, and 2) the ability to produce fungistatic and bacteriostatic compounds and to tolerate fungistatic compounds (Shearer, 1995).

1) *Lentinula edodes* is a white rot fungus that is found in the wild on woods. For its cultivation on other lignocellulosic substrates, it is necessary to select strains well adapted to this alternative substrate. Shiitake generally grows slowly by producing dense mycelia and it utilizes both available nutrients and polysaccharides bounds to lignin thanks to its ability to produce extracellular enzymes useful for degrading lignocellulosic materials: phenoloxidasés and hydrolases (Savoie *et al.*, 2000). However different shiitake strains show different abilities to grow, fructify and resist antagonistic moulds. By comparing the metabolic activities and the production of extracellular enzyme activities of different shiitake strains cultivated on sterilized wheat straw, we observed that the strains with the earlier production and higher yield were those able to hydrolyze and utilize straw cell wall components soon after inoculation and that developed high metabolic activities (Mata and Savoie, 1998).

The number of strains in a collection adapted to a specific substrate could be relatively low. For their selection, also for the improvement by breeding, it is then necessary to have a large collection and to develop screening methods evaluating their ability for space and nutrient capture. For example, estimates of mycelial growth on malt and yeast extracts agar supplemented with water soluble lignin derivatives were proposed as indicator of a strain's potential for mycelial growth on substrates derived from wheat straw (Mata *et al.*, 2001).

2) During competition between shiitake and moulds such as the *Trichoderma* genus or bacteria in non-sterilized or contaminated substrates, several mechanisms of chemical interference are involved. Abilities to produce and to resist various antibiotics, to limit the growth of potential antagonists and to resist the attack of antagonists that can be present in a specific cultivation substrate are another set of important traits of strains that can be selected. Confrontation experiments between mycelia or between mycelia and bacteria are often used on both agar and solid media for evaluating their relative competitive ability. Several emergence patterns of non-assimilative mycelia including pigmented barrages have been identified during such confrontations and contribute to the defense against the antagonist (Rayner *et al.*, 1994; Savoie *et al.*, 2001). Visual observations of such reactions can easily be used to evaluate this component of the competitive saprophytic ability of shiitake strains (Figs. 2). Overgrowing and cell lyses can also be observed during interactions (Tsuneda and Thorn, 1994). Alternatively, the production of specific compounds of the defense reaction such as laccases can be assayed when laboratory facilities are available (Savoie *et al.*, 1998).

When strains with efficient competitive saprophytic abilities are selected for an alternative cultivation substrate, it is interesting to give them the better cultivation conditions allowing the expression of their potentialities. That can be reached by improving the spawn.



**Figure 2.** Confrontations of shiitake mycelium with *Trichoderma* moulds. Shiitake mycelium is blocking mould progression on wheat straw.

### Improvement of the resistance to moulds by spawn adaptation

It was shown that the competitive ability of shiitake strains in wheat straw could be improved during the first days after spawning by modifying the composition of components used for spawn production, and consequently the incidence of moulds was reduced by 75% (Mata *et al.*, 1998; Savoie *et al.*, 2000). In these experiments, the preparation of a grain spawn supplemented with components rich in lignin and phenols has allowed a considerable reduction of contamination during the first growth stages by comparison to non supplemented grain spawn. By pre-adaptation of mycelium to the degradation of the lignocellulosic substrate in which the cultivation of shiitake was performed, the supplements acted as inducers of the defense systems. Actually most of shiitake strains are able to produce emergent hyphae and a dark brown line in the contact zone with moulds in order to block moulds progression (Figs. 2), but due to the delay for developing this defense, large area of the substrate is colonized by the antagonists before being stopped in their growth by this barrage.

The barrage is the result of an over production of phenoloxidases (laccases) and this over expression is also induced by lignin derivatives and various phenolic compounds. Consequently due to the presence of such compounds in the spawn, the reaction time is decreased when the mycelia face moulds in the cultivation substrate. In addition its overall competitive ability is improved because it is also adapted for the degradation of lignified components of the cultivation substrate.

Some strains of shiitake are able to grow on artificial media added with crude extracts of cultures of *Trichoderma harzianum*. Some commercial preparations are partially purified extracts of *Trichoderma*, usually used for their properties of plant and fungal cell wall lyses (for instance, Lysing Enzyme from Sigma®). This ability of shiitake mycelium pre-adapts the mushroom to *Trichoderma* moulds antagonism. During this pre-adaptation the growth rate is decreased and laccases are induced as above, but rapidly the mycelium reaches again its initial growth rate. When such mycelium is confronted by *Trichoderma* mycelium the lag time for the production of the barrage was decreased by one third and the production of spores was reduced by comparison with non pre-adapted mycelium (Mata *et al.*, 2001; Savoie and Mata, 2003). Improvement in the resistance to antagonists by introduction of some of their metabolites to the culture medium is a very efficient method by which to select strains with a high level of resistance.

### ■ Production and Use of Supplemented Grain Spawn

The use of different spawn formulas has demonstrated that the strains have different adaptive possibilities to grow on the components of supplemented spawn. These differences could be limitative to select strains for supplemented spawn production.

However, strains having these abilities are very important genetic resources that open the possibility to use wheat straw and other agricultural by-products to shiitake cultivation. Based on the knowledge of the competitive abilities of shiitake strains, it is possible to propose means for giving an advantage to the mushroom, during spawn preparation, and decreasing the impact of *Trichoderma* spp. when shiitake is cultivated on wheat straw: 1) addition of raw material rich in phenolic compounds with high adsorption capacity, 2) increase of the number of inoculum points per volume of substrate by using spawn supports with a low granulometry, 3) increase of the vigor of mycelium by strain selection and pre-adapting the mycelium to the degradation of lignocellulosics.





**Figure 3.** Some different grains commonly used in shiitake spawn preparation **A:** Millet **B:** Oat **C:** Wheat **D:** Sorghum

Grain spawn can be prepared using sorghum (*Sorghum vulgare* Pers.) or millet (*Panicum milliaceum* L.) seeds. Other grains could be also used but it is very important to consider seeds size (Figs. 3).

Supplements with high capacity of water retention and containing phenolic compounds as peat moss and coffee pulp can be used. Some formulations of shiitake spawn have been tested with very good results (Del Pino *et al.*, 2002; Mata *et al.*, 2002) (Table 1).

**Table 1.** Some formulations showed very good mycelial growth (%)

	Sorghum seeds	Millet seeds	Peat moss	Gypsum	Coffee pulp powder	Wheat bran	Wheat straw powder
Formula 1	88.5		1.3	1.3	8.8		
Formula 2		88.5	1.3	1.3	8.8		
Formula 3	88.5		1.3	1.3		8.8	
Formula 4		88.5	1.3	1.3		8.8	
Formula 5	88.5		1.3	1.3			8.8
Formula 6		88.5	1.3	1.3			8.8

Seeds must be hydrated separately by soaking them at least 12 hours. After that they must be drained off excess moisture with a domestic centrifuge and then the remaining ingredients added. The mixture must be adjusted to a moisture content of 75 % (Figs. 4).



**Figure 4.** Supplemented shiitake spawn preparation **A:** Washing seeds **B:** Centrifugation of seeds **C:** Filling the plastic bags for sterilization

Prepared formulas can be placed in plastic bags and sterilized in autoclave for 90 minutes at 121 °C. After cooling the bags containing the mixture of the formula are inoculated with mycelium cultivated for 15 days on artificial culture medium like malt extract agar (Figs. 5).

The incubation must be carried out at 25 °C in darkness. In order to obtain a good spawn the bags must be shaken carefully after two weeks of incubation in order to distribute the growing hyphae throughout the mixture and encourages a rapid growth. A good stage of maturation of shiitake spawn is obtained after 3-5 weeks of incubation (Figs. 6).



**Figure 5.** Supplemented shiitake spawn preparation **A:** Plastic bags with the prepared formula ready for sterilization **B:** Transferring a square of mycelium from the artificial medium into sterilized formula of supplemented spawn **C:** Mycelial growth during spawn incubation **D:** Mycelial growth on millet supplemented spawn.



**Figure 6.** Supplemented shiitake spawn **A:** Incubation room with a shelf system **B:** Supplemented spawn after 3 weeks of incubation

## REFERENCES

- Buswell, J.A., Y.J. Cai, and S.T. Chang. 1993. Fungal and substrate-associated factors affecting the ability of individual mushroom species to utilize different lignocellulosic growth substrates. In: Chang, S.T., J.A. Buswell, and S.W. Chiu, eds: *Mushroom Biology and Mushroom Products*. Hong Kong: The Chinese University Press. pp. 141-150.
- Del Pino, A., R.G. Hernández, and G. Mata. 2002. Evaluación de cepas de shiitake (*Lentinula edodes*) en diversas formulaciones de inóculo, para su cultivo en paja de trigo pasteurizada. In: Guzmán, G., and G. Mata, eds: *Nanacatepec*. Xalapa: Universidad Veracruzana. pp. 489.
- Donoghue, J.D., A.K. Somonson, and W.C. Denison. 1996. Spawning techniques for sawdust based shiitake production: past, present and future. *Mushroom News* 44 (7): 6-17.
- Kozak, M.E. and J. Krawczyk. 1989. *Growing Shiitake Mushrooms in a Continental Climate*. ABC Printers, Marinette.
- Leatham, G.F. and T.J. Griffin. 1984. Adapting liquid spawn of *Lentinus edodes* to oak wood. *Applied Microbiology and Biotechnology* 20: 360-363.
- Mata, G. and J.M. Savoie. 1998. Extracellular enzyme activities in six *Lentinula edodes* strains during cultivation in wheat straw. *World Journal of Microbiology and Biotechnology* 14: 513-519.
- Mata, G., J.M. Savoie, P. Delpuch, and J.M. Olivier. 1998. Reduction of the incidence of *Trichoderma* spp. using substrate supplementation with peat and an alternative spawn during cultivation of *Lentinula edodes* on pasteurized wheat straw. *Agronomie: Agriculture and Environment* 18: 515-520.
- Mata, G., P. Delpuch, and J.M. Savoie. 2001. Selection of strains of *Lentinula edodes* and *Lentinula boryana* adapted for efficient mycelial growth on wheat straw. *Revista Iberoamericana de Micología* 18: 118-122.
- Mata, G., R. Gaitán-Hernández, R. Pérez-Merlo and C. Ortega. 2002. Improvement of shiitake spawn for culturing on pasteurized wheat straw. In: Sánchez, J.E., G. Huerta, and E. Montiel, eds: *Mushroom Biology and Mushroom Products*. Cuernavaca, Mexico: UAEM. pp. 303-309.
- Ohmasa, M., and M.L. Cheong. 1999. Effects of culture conditions of *Lentinula edodes*, "shiitake mushroom," on the disease resistance of *Lentinula edodes* against *Trichoderma harzianum* in the sawdust cultures. In: *Proceedings of the 3<sup>rd</sup> International Conference on Mushroom Biology and Mushroom Products*. WSMBMP, Sydney.
- Przybylowicz, P., and J. Donoghue. 1988. *Shiitake Growers Handbook: the Art and Science of Mushroom Cultivation*. Dubuque, Iowa: Kendall/Hunt Publishing Company.
- Rayner A.D.M., G.S. Griffith, and H.G. Wildman. 1994. Induction of metabolic and morphogenetic changes during mycelial interactions among species of higher fungi. *Biochemical Society Transactions* 22: 389-394.
- Savoie, J.M., and G. Mata. 2003. *Trichoderma harzianum* metabolites pre-adapt mushrooms to *Trichoderma aggressivum* antagonism. *Mycologia* 95: 191-199.
- Savoie, J.M., P. Delpuch, C. Billele, and G. Mata. 2000. Inoculum adaptation changes the outcome of the competition between *Lentinula edodes* and *Trichoderma* spp. during shiitake cultivation on pasteurized wheat straw. In: Van Griensven, L.J.L.D. ed: *Science and Cultivation of Edible Fungi*. Rotterdam, the Netherlands: A.A. Balkema. pp. 667-674.
- Savoie, J.M., G. Mata, and M. Mamoun. 2001. Variability in brown line formation and extracellular laccase production during interaction between white-rot basidiomycetes and *Trichoderma harzianum* biotype Th2. *Mycologia* 93: 234-248.
- Shearer, C.A. 1995. Fungal competition. *Canadian Journal of Botany* 73: S1259-S1264.
- Tsuneda A., and G. Thorn. 1994. Interactions between *Lentinula edodes* and pseudomonads. *Canadian Journal of Microbiology* 40: 937-943.

## Part I Shiitake

## Chapter 2

Shiitake Spawn and Strain**PRESERVATION OF SHIITAKE SPAWN STOCKS  
BY CRYOGENIC STORAGE**

Gerardo Mata\* and Dulce Salmones

Unidad de Micología, Instituto de Ecología, Apdo. Postal 63, Xalapa 91000, Ver., México \*(gerardo\_mata2000@yahoo.fr)

**Introduction**

The long-term preservation of the special properties and characteristics of a cultivated mushroom strain requires continual maintenance. The common method of continuous subculture<sup>1</sup> of strains on artificial media (the traditional method) provides an effective short-term preservation of mushroom strains. Yet this system can increase the risk of accidental contamination and/or changes in the morphological and physiological characteristics of the organisms (Jong and Davis, 1986). Continuous subculture is time consuming, laborious and impractical for large collections of mushroom strains.

**Continuous Subculture:** Strict hygiene and environmental control (dark storage at 4 °C) should be maintained to avoid mycelial degeneration caused by factors such as pathogens, mutations and metabolic activities.

Pick the small edge of a colony and put it at the center of a petri dish or in the center or lower part of a test tube full of fresh media. When picking the sample, avoid the old media (the first inoculated, central part of the colony) that may now contain metabolic compounds that retard new mycelial growth. Browned parts should not be used. These new young healthy samples from the culture should be transferred to fresh media periodically. PDA (Potato Dextrose Agar) and YMA (Yeast Malt extract agar) are the usual media.

When the colony covers 70% of the media in the petri dishes, store them at 4-5 °C in darkness. They can be stored for 3-4 months in this manner before the next subculture is made.

Tubes (Ø 18mm × h150-180mm) should have a slanted media which is less than 30 degrees. When closed by a silicon cap, these tubes can be stored for 5-12 months at 8-15 °C and 60% relative humidity. Tubes can be stored for 3-6 months when sealed with a cotton cap.

Different long-term preservation methods have been developed in order to improve and preserve the genetic stability of strains. Today liquid nitrogen storage is accepted as the best preservation technique for long term storage of mushroom mycelia (Chvostová *et al.*, 1995). This freezing process must be carefully managed in order for the mycelia to be frozen and successfully recovered. To avoid ice crystal formation and the cell damage caused by freezing in liquid nitrogen (-196 °C), cryoprotective<sup>2</sup> solutions (cryoprotectants) are used.

The pioneer studies in this arena of fungal conservation at ultra-low temperatures were made before 1960 (Hwang, 1960). Since then, many different methods and materials have been evaluated in an effort to optimize the process. The viability of the frozen samples depends upon the mushroom species and the strain. Additionally, the age of mycelium, its growth conditions, the type of cryoprotectant being used and its rate penetration into the mushroom cells, and the methods and rate of freezing and thawing all affect the eventual success or failure (Chvostová *et al.*, 1995; Mata *et al.*, 2000).

The cryopreservation of superior mushroom strains is generally undertaken by cutting agar blocks from growing cultures

<sup>1</sup> Subculture: an act of producing another culture of microorganisms derived from an original culture

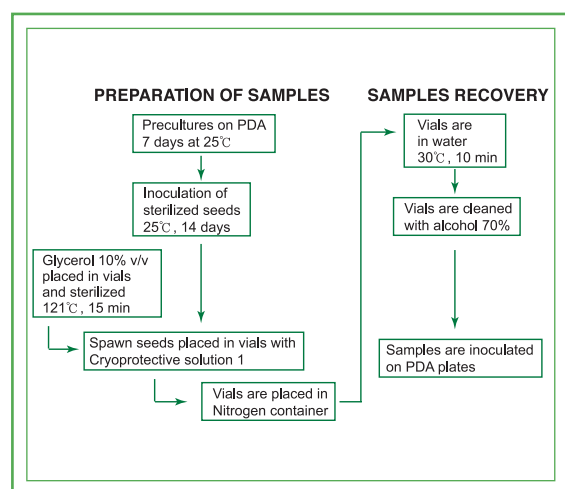
<sup>2</sup> Cryoprotective: serving to protect against the deleterious effects of subjection to freezing temperatures

and then immersing them in a cryoprotectant. After immersion in the cryoprotective solution, the agar blocks are gradually cooled from ambient temperature to  $-40\text{ }^{\circ}\text{C}$  at a rate of  $1\text{--}10\text{ }^{\circ}\text{C}/\text{min}$  (Smith, 1993, 1998) and then placed in liquid nitrogen. Both the gradual freezing of samples and the use of cryoprotective solutions have been considered absolutely necessary for the adequate recovery of the mycelia (Roquebert and Bury, 1993; Chvostová *et al.*, 1995). However, good recovery of mycelia has been obtained with procedures using different spawn stocks, and different techniques.

For example *Agaricus bisporus* (the button mushroom) will grow mycelia from frozen spawn prepared with gramineous<sup>3</sup> seeds, when a pre-freezing procedure is used (Hwang and San Antonio, 1972, 1982; Kneebone *et al.*, 1974; Jodon *et al.*, 1982; Suman and Jandaik, 1991). Frozen mycelia have also been recovered for *Volvariella volvacea*, *Pleurotus* spp. and *Lentinula* spp. when the spawns were instantly frozen in cryoprotective solutions (Pérez and Salmones, 1997; Lara Herrera *et al.*, 1998 a, b; Mata *et al.*, 2000). It is very interesting to note that in the majority of the last cited cases, mycelial recovery and new growth were initiated from seed hila<sup>4</sup> or from fissures on the surface of the gramineous seeds. These results suggest that the seeds might have acted as mycelial protectors. In particular, although cellular contents are known to crystallize with rapid freezing, neither immediate freezing of the spawn nor the absence of cryoprotective substances appears to have been lethal in these studies. In support of this hypothesis, mycelia were recently successfully recovered from spawn rapidly frozen in liquid nitrogen without the use of cryoprotectant (Mata and Pérez Merlo, 2003). Although the exact mechanism by which the mycelium is protected by the spawn seeds remains unclear, the sample viability obtained with this method is very high (72–100%).

This paper shows the results of a developed methodology. It is a simple and inexpensive freezing system for conserving and recovering edible mushroom strains.

## Spawn Preparation and the Freezing and Thawing of Samples



**Figure 1.** Important aspects of the method for spawn preservation by cryogenic storage

Shiitake strains must be pre-cultured for 7 days on petri dishes with a solid media of potato dextrose and agar (PDA). Figure 1 shows the most important aspects of the method for spawn preservation by cryogenic storage.

Spawn must be prepared by the conventional method with pre-treated sorghum seeds (*Sorghum vulgare*) hydrated to 65% and then sterilized at  $121\text{ }^{\circ}\text{C}$  for 1 hour. After sterilization the sorghum seeds must be placed in sterile petri dishes. Each dish must then be inoculated with a pre-cultured mycelium, plus its agar disc ( $\pm 0.5\text{ cm}$  in diameter). Inoculated dishes, sealed with elastic plastic film, must be incubated in darkness for 14 days (at  $25\text{ }^{\circ}\text{C}$ ), allowing mycelial growth to completely cover the sorghum grains.

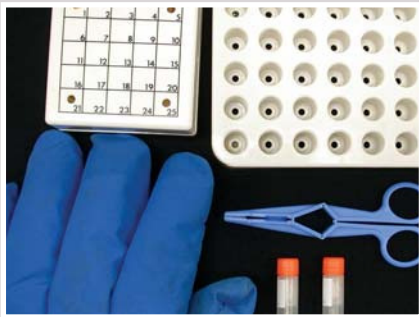
Special polycarbonate vials (NALGENE): Polycarbonate boxes (for vial arranging inside the liquid nitrogen container) and gloves must be used for freezing in liquid nitrogen (Fig. 2). The cryoprotective solution is prepared with glycerol (10% v/v) and distilled water. The cryoprotective solution is placed into the vials and sterilized at  $121\text{ }^{\circ}\text{C}$  for

15 minutes. After cooling, the spawn of fully-incubated sorghum seeds must be placed in the vials (25 seeds per vial) (Figs. 3). The samples must remain in contact with the cryoprotective solution for 1 hour, and then the vials in their polycarbonate containers can be placed directly into the liquid nitrogen (Fig. 4).

For strain recuperation, the vials must be removed from the liquid nitrogen and thawed by submergence in distilled water at  $30\text{ }^{\circ}\text{C}$  for 10 min (Mata *et al.*, 2000) (Fig. 5). Once thawed, the vials are cleaned for 1 min with an alcohol solution (70% v/v). After cleaning, the cryoprotectant is drained off and the seeds are placed in petri dishes with PDA in order to encourage mycelial recovery and growth. It is very important to carry out this part of the process in a sterile environment using a laminar flow hood.

<sup>3</sup> Gramineous: of, relating to, or characteristic of grasses

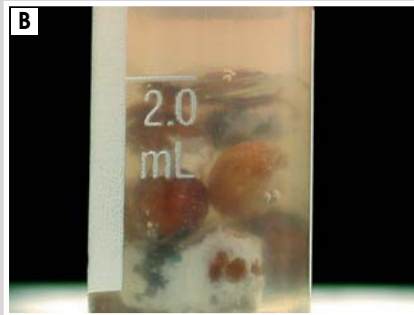
<sup>4</sup> Hila: sg. hilum. scars on a seed



**Figure 2.** Material and tools used for freezing spawn stocks



**Figure 4.** Vials placed in polycarbonate containers directly frozen in liquid nitrogen



**Figure 3.** Spawn fully-incubated sorghum seeds in dishes (A) and placed in the vials with cryoprotectant (B)

## ■ Mycelial Growth and Viability Tests

When this system is used, usually after thawing, all sorghum grains had lost the external mycelial layers that had covered them. The mycelia from all samples will usually be recovered from seed hila, or from fissures on the seed surfaces (Mata and Pérez-Merlo, 2003) (Figs. 6). The rate of recovery in seed samples varies according to the treatment and the species. Strains of *Pleurotus djamor*, *P. pulmonarius*, *P. columbinus*, *V. volvacea*, *Lentinula edodes* and *L. boryana* have showed 100% recovery (Mata and Pérez-Merlo, 2003; Mata *et al.*, 2004). Factors such as the age and physiological state of the hyphae, as well as its cytoplasmic contents, may have affected the capacity of mushroom cells to resist freezing and thawing (Smith and Thomas, 1998). Previous studies (Lara Herrera *et al.*, 1998a; Mata *et al.*, 2000) showed that treating spawn stocks with a cryoprotective solution of glycerol, without pre-freezing, resulted in 100% recovery of *Pleurotus* and *Lentinula* strains. Furthermore, no differences in mushroom production were observed. Spawn viability of *Pleurotus* spp. strains was not affected by liquid nitrogen for 8 years. No significant differences were observed in mycelial growth rate or in mushroom morphology or size (Mata *et al.*, 2004).



**Figure 5.** Thawing vials for strain recuperation



**Figure 6.** Mycelium recovered from seed hilum (A) and samples completely recovered after cryopreservation (B)

## REFERENCES

- Chvostová, V., F. Nerud, and L. Homolka. 1995. Viability of wood-inhabiting basidiomycetes following cryogenic preservation. *Folia Microbiologica* 40: 193-197.
- Hwang, S.W. 1960. Effects of ultra low temperatures on the viability of selected fungus strains. *Mycologia* 52: 527-529.
- Hwang, S.W., and J.P. San Antonio. 1972. Stability of spawn stocks of the cultivated mushroom after 26 months liquid nitrogen refrigeration (-160 °C to -196 °C). *Mushroom Science* 8: 35-42.
- Jodon, M.H., D.J. Royse, and S.C. Jong. 1982. Productivity of *Agaricus brunnescens* stock cultures following 5-, 7-, and 10-year storage periods in liquid nitrogen. *Cryobiology* 19: 602-606.
- Jong, S.C., and E.E. Davis. 1986. Germoplasm preservation of edible fungi in culture through cryogenic storage. In: West, P.J., Royse, D.J., and R.B. Beelman, eds: *Cultivating Edible Fungi*. New York: Elsevier. pp. 213-225.
- Kneebone, L.R., S.W. Hwang, P.G. Shultz, and T.G. Patton Jr. 1974. Comparative production performance of stock cultures of eight strains of *Agaricus bisporus* preserved by liquid nitrogen freezing and by repeated vegetative transfer. *Mushroom Science* 9: 229-235.
- Lara-Herrera, I., G. Mata, and R. Gaitán-Hernández. 1998a. Evaluation of the viability of *Pleurotus* spp. strains after liquid nitrogen cryopreservation. *Revista de Microbiología* 29: 192-195.
- Lara-Herrera, I., G. Mata, and R. Gaitán-Hernández. 1998b. Evaluación del efecto de la criopreservación de cepas de *Pleurotus* sp. sobre la producción de carpóforos. *Revista Iberoamericana de Micología* 15: 44-47.
- Mata, G., and R. Pérez-Merlo. 2003. Spawn viability in edible mushrooms after freezing in liquid nitrogen without a cryoprotectant. *Cryobiology* 47: 14-20.
- Mata, G., D. Salmones, and P.M. Ortega. 2000. Viability and mushroom production of *Lentinula edodes* and *L. boryana* strains (Fungi: Basidiomycetes) after cryogenic storage of spawn stocks. *World Journal of Microbiology and Biotechnology* 16: 283-287.
- Mata, G., D. Salmones, and R. Gaitán. 2004. Spawn viability and mushroom production in *Pleurotus* strains frozen for eight years in liquid nitrogen. In: Romaine, P., C.B. Keil, D.L. Rinker, and D.J. Royse, eds: *Science and Cultivation of Edible and Medicinal Fungi*. PennState University, University Park. pp. 185-191.
- Pérez, R., and D. Salmones. 1997. Viabilidad de cepas de *Volvariella volvacea* conservadas en nitrógeno líquido. *Revista Mexicana de Micología* 13: 78-80.
- Roquebert, M.F., and E. Bury. 1993. Effect of freezing and thawing on cell membranes of *Lentinus edodes*, the shiitake mushroom. *World Journal of Microbiology and Biotechnology* 9: 641-647.
- San Antonio, J.P., and S.W. Hwang. 1982. Liquid nitrogen preservation of *Agaricus bisporus* (Lange) Sing. spawn stocks. *Mushroom Journal* 120: 410-419.
- Smith, D. 1993. Culture collection. In: Chang S.T., J.A. Buswell, and P.G. Miles, eds: *Genetics and Breeding of Edible Mushrooms*. Amsterdam: Gordon and Breach Science Publishers. pp. 15-33.
- Smith, D. 1998. The use of cryopreservation in the *ex-situ* conservation of Fungi. *Cryo-Letters* 19: 79-90.
- Smith, D., and V.E. Thomas, 1998. Cryogenic light microscopy and the development of cooling protocols for the cryopreservation of filamentous fungi. *World Journal of Microbiology and Biotechnology* 14: 49-57.
- Suman, B.C., and C.L. Jandaik. 1991. Preservation of culture of *Agaricus bisporus* (Lange) Sing. in liquid nitrogen and its effect on yield and characters of fruiting bodies. *Indian Journal of Mycology and Plant Pathology* 21: 34-37.

## Part I Shiitake

## Chapter 3

Shiitake Log Cultivation

## SHIITAKE LOG CULTIVATION

Keisuke Tokimoto

The Tottori Mycological Institute, Kokoge-211 Tottori, 689-1125, Japan (kin-tkmt@infosakyu.ne.jp)

## Introduction



**Figure 1.** Fruiting bodies of shiitake, *Lentinula edodes* (Berk.) Pegler, on a log

Shiitake is a wood-decaying fungus that lives on dead broadleaf trees, particularly of the oak family (Fig. 1). Since shiitake was first cultivated on logs about 1,000 years ago, log cultivation has been the most common cultivation method, but this has changed recently. Bag cultivation of shiitake using sawdust packed into plastic bags was developed in the early twentieth century, and many shiitake growers have converted to bag cultivation due to the short production cycle and quick return of capital. However, log cultivation that uses a forest environment still has some advantages over artificial sawdust cultivation. Shiitake log cultivation requires less care and labor because it accepts natural conditions rather than requiring controlled conditions. The bark of the logs provides protection for shiitake mycelia and logs attract fewer microorganisms due to their low water content (Przybylowicz and Donoghue, 1990). Though it takes a longer time for the inoculated logs to be fully colonized and produce fruiting bodies, shiitake cultivated on logs are usually of a high quality with thick caps and fragrant odor. Log cultivation also causes less environmental pollution. In general, shiitake produced by log cultivation contained much more of polysaccharide than those cultivated by sawdust cultivation (Brauer *et al.*, 2002), and lentinan, an anti-tumor polysaccharide of shiitake, shows similar relations (Tokimoto *et al.*, unpublished).

**Table 1.** Annual production of shiitake in Japan (ton)

Year	Dried shiitake			Fresh shiitake			
	Production on logs	Import	Export	Production on logs	Production on sawdust	Import	Export
1975	11,356	93	2,695	58,560	-*	0	0
1985	12,065	140	3,330	74,706	-*	0	0
1999	5,582	9,146	156	36,069	34,442	31,628	0
2000	5,236	9,144	115	32,567	34,657	42,057	0
2001	4,964	9,253	151	28,542	37,586	36,301	0
2002	4,449	8,633	118	25,400	39,042	28,148	0

\* Volumes of production from sawdust in 1975 and 1985 were not calculated, but actually zero.

Source: Forestry Agency, Japan, 2003

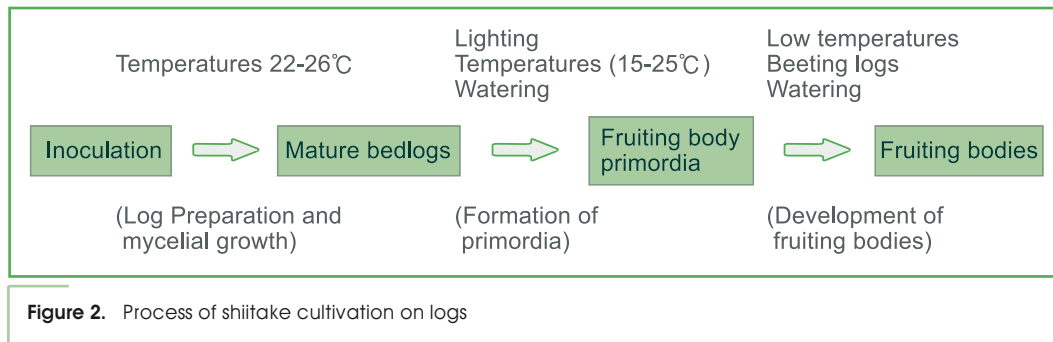
Japan has been one of the main producers of shiitake on logs. For the Japanese market, the thickest and largest shiitake are dried and the rest are usually consumed fresh. Dried shiitake is usually produced from logs and fresh shiitake is produced

both from logs and sawdust (Table 1). Shiitake cultivation increased from 1950 to 1984 in Japan, but, production declined after 1985 mainly because of the exchange rate in favor of the yen. Most shiitake used to be produced from logs, but now about 36%<sup>1</sup> of the Japanese shiitake, both dried and fresh, is produced from sawdust.

South Korea produced 1,937 tons of dried shiitake and 22,374 tons of fresh shiitake in 2003 (Korea Forest Service, 2003). Separate statistics on production with logs and sawdust are not available, but it is mostly accepted that more than 95% of the Korean shiitake is produced from logs. On the other hand, most of the shiitake production in China is from sawdust bags.

The process of log cultivation involves three stages: 1. The log preparation and the growth of the vegetative mycelium, 2. The formation of fruiting body primordia, and 3. The development of fruiting bodies (Fig. 2).

## Log Preparation and Mycelial Growth

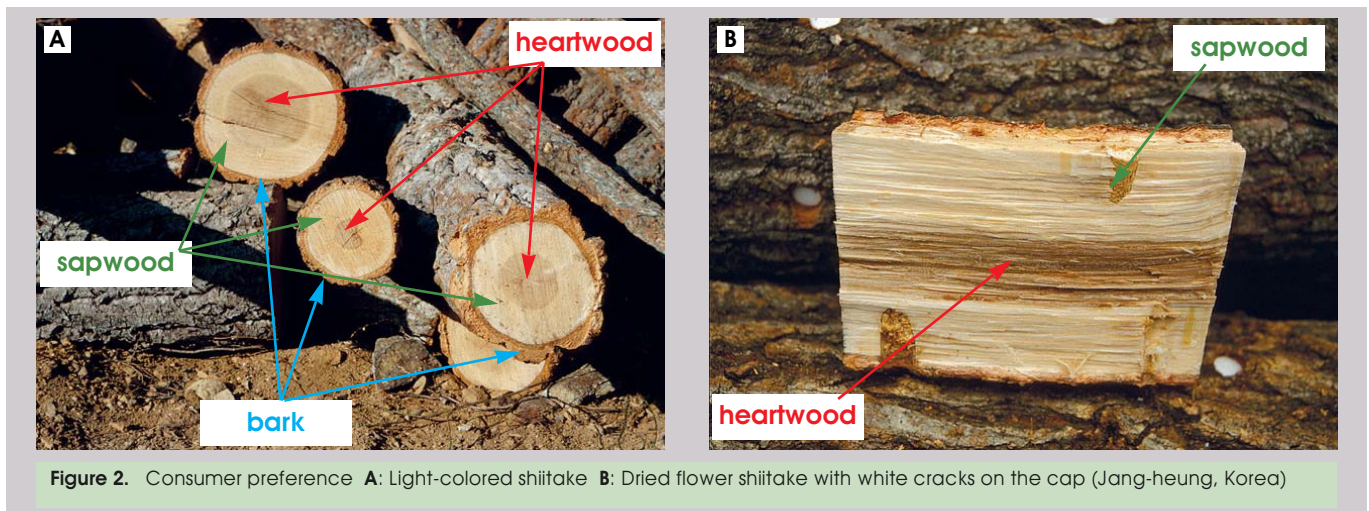


Preparation of well-colonized logs is one of the most important requirements for fruiting body formation. This stage consists of the selection of host trees, felling and cutting, inoculation, and spawn run.

### Selection of host trees

Logs are mainly composed of polysaccharides, cellulose and hemicellulose, and lignin, which are all decomposed by shiitake mycelia and used as their energy source. Sugars play important roles in the initial mycelial growth. Logs have a relatively low amount of nutrients compared with other agricultural wastes. This low nutritional availability also makes logs unattractive to other microorganisms. The bark on a log also provides very efficient protection from the attacks of other fungi and molds and it also prohibits moisture evaporation from the log. Once shiitake spawn is inoculated beneath the protective bark, it has essentially an exclusive access to nutrients in the wood, a fact that makes logs quite attractive as locations for cultured shiitake (Przybylowicz and Donoghue, 1990).

The main structures of a log are bark, sapwood, and heartwood (Fig. 3A). The bark is divided into inner bark and outer bark, and the former is the area where fruiting body primordia are formed. Sapwood is distinguished from heartwood by its color, as sapwood is lighter than heartwood. Shiitake mycelia colonize sapwood, which contains available polysaccharides, but do not grow easily into heartwood (Fig. 3B). Therefore, it is recommended that growers choose logs with a wide sapwood section.



<sup>1</sup> Productions of fresh shiitake with logs and sawdust are estimated about 2,600 and 3,900 tons in dry weight, respectively.

In China, Korea, and Japan, many growers choose primarily oak (*Quercus*) trees. Although many factors affect the suitability of logs for shiitake cultivation, bark is one of the most important factors. Oak logs have strong bark that keeps its forms for many years, and is thus able to fruit for a long period of time, perhaps as long as four to five years (Fig. 3A). In tropical countries, oak trees inhabit the highlands. Cultivation using logs from oak trees has been tried in India (Lee, 1978), Thailand (Triratana, 1993), and other countries.

Though oak is preferred for shiitake log cultivation, shiitake can be and has been cultivated on other various hard and soft woods around the world. Each log species produces different amounts of shiitake with various qualities for various periods. Logs from softwood trees, which are also capable of cultivation, tend to start fruiting earlier than those of hardwood trees but exhaust their fruiting capacity more quickly.

Tree species tested for suitability of shiitake cultivation are listed according to Przybylowicz and Donoghue (1990), (Table 2).

**Table 2.** Tree species tested for suitability for shiitake production

Common name	Family	Genus	Species
<b>High suitability</b>			
Oak	Fagaceae	<i>Quercus</i>	<i>acutissima, alba, brandisiana, crispula, dentata, garryanna, kelloggii, kerii, kingiana, mongolica, muehlenbergii, prinus, rubra, semiserrata, serrata, variabilis</i>
Chinkapin	Fagaceae	<i>Castanopsis</i>	<i>accuminatissima, argentea, chrysophylla, cuspidata, indica</i>
Tanoak	Fagaceae	<i>Lithocarpus</i>	<i>auriculatus, densiflorus, lanceaefolia, lindleyanus, polystachyus</i>
Hornbeams	Fagaceae	<i>Carpinus</i>	<i>betula, caroliniana, japonica, laxiflora, tschonoski</i>
<b>Medium suitability</b>			
Alder	Betulaceae	<i>Alnus</i>	<i>glutinosa, japonica, rubra, serrulata, tinctoria</i>
Aspen, Poplar, Cottonwood	Betulaceae	<i>Populus</i>	<i>balsamifera, deltoides, grandidentata, nigra, trichocarpa</i>
Beech	Fagaceae	<i>Fagus</i>	species
Birch	Betulaceae	<i>Betula</i>	<i>nigra, pendula</i>
Chestnut	Fagaceae	<i>Castanea</i> ,	<i>crenata</i>
		<i>Cyclobalanopsis</i>	<i>acuta, glauca, salicina, myrsinifolia</i>
Hickory	Juglandaceae	<i>Carya</i>	species
Maple	Aceraceae	<i>Acer</i>	<i>rubrum, macrophyllum</i>
Sweetgum	Hamamelidaceae	<i>Liquidambar</i>	<i>styraciflua</i>
Tupelo	Nyssaceae	<i>Nyssa</i>	<i>silvatica</i>
Willow	Salicaceae	<i>Salix</i>	<i>nigra</i>
<b>Low suitability</b>			
Cucumbertree	Magnoliaceae	<i>Magnolia</i>	<i>accuminata</i>
Tulip poplar	Magnoliaceae	<i>Liriodendron</i>	<i>tulipifera</i>
Dogwood	Cornaceae	<i>Cornus</i>	<i>florida</i>
Apple	Rosaceae	<i>Malus</i>	<i>sylvestris</i>
Sycamore	Platanaceae	<i>Plantanus</i>	<i>occidentalis</i>
Virginia pine	Pinaceae	<i>Pinus</i>	<i>virginiana</i>

Note: Trees considered highly suitable are widely used, while medium suitability trees require careful management. Trees with low suitability are not recommended for commercial shiitake production.

Source: Przybylowicz and Donoghue, 1990



Quercus acutissima



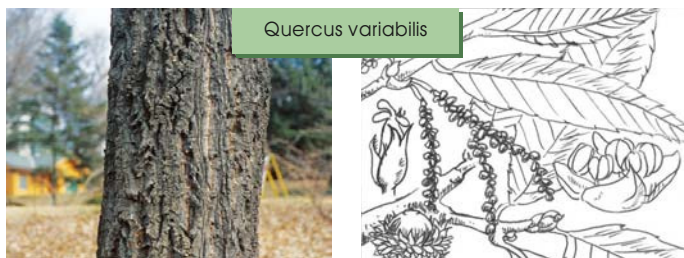
Quercus dentata



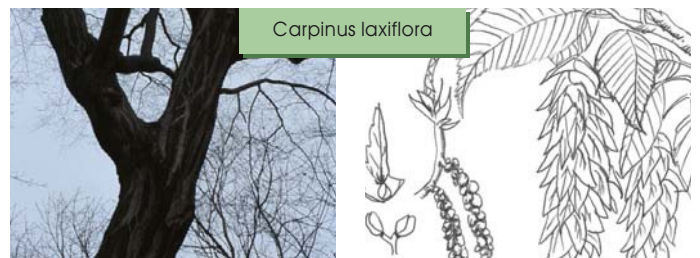
Quercus mongolica



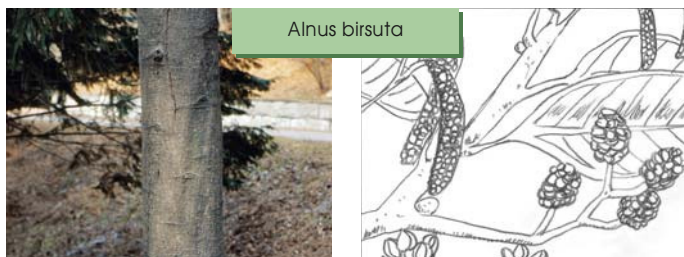
Quercus serrata



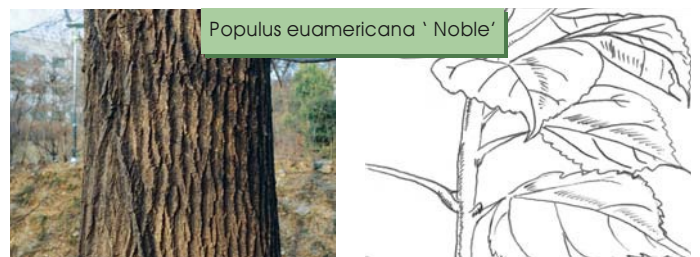
Quercus variabilis



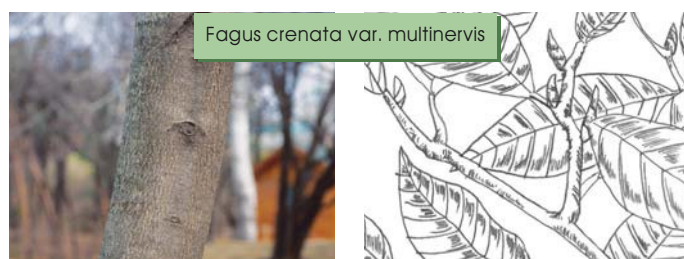
Carpinus laxiflora



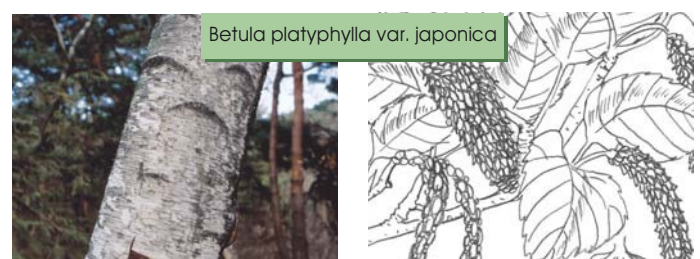
Alnus birsuta



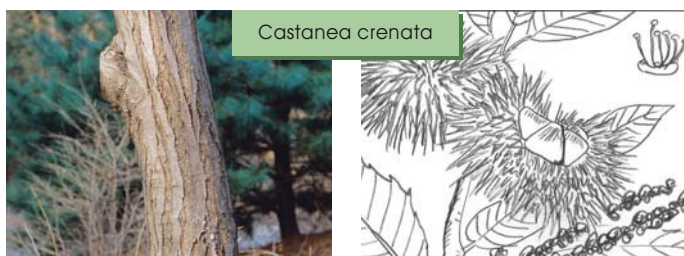
Populus euamericana 'Noble'



Fagus crenata var. multinervis



Betula platyphylla var. japonica



Castanea crenata



Acer pictum var. dissectum



Quercus aliena

Figure 4. Leaves and barks of trees used for log cultivation of shiitake

### Tree felling, cutting and storage

Once most appropriate trees are selected, it is recommended that growers fell them during the dormant season of trees, although the stage of “leaf-reddening” is the best for *Quercus* trees. Trees 5-15cm in diameter are appropriate for shiitake logs. The felled trunks are usually cut into logs about 100cm in length and dried slightly. If the felled trees still have green leaves, they are dried for a period less than 10 days. This water reduction weakens the resistance of the logs to the shiitake mycelia and enables better mycelial growth. On the other hand, shiitake mycelium itself requires water for its growth. Therefore, excessive drying should be avoided. Drying may be excessive if logs are stored for a long period before spawning. To control the water content of logs and keep it within a suitable ranges (30-35% in wet base for *Quercus* trees), logs are generally piled up less than 50cm high and sheltered from direct sunlight. Long storage under warm conditions (more than 10 °C) also involves some risk of the contamination with other microorganisms.



Figure 5. Preparation of logs A: Cutting B: Conveying C: Storage before inoculation

### Choice of log and felling time for better mycelial growth

#### Death of woody cells

The speed of colonization of shiitake in logs is closely correlated to the viability of the woody cells (Komatsu *et al.*, 1980; Shimomura and Hasebe, 2004). Less viable cells are preferred for colonization by shiitake mycelia. In countries with four distinct seasons such as Japan and Korea, *Quercus* trees are felled in late autumn when the leaves remain partially green. The logs are left on the felling site for more than 10 days with the leaves attached. By this treatment, an excess of water is gradually and evenly lost from the wood tissues, mainly through the green leaves. This process promotes the death of living cells in the inner bark, cambium, and sapwood regions.

If trees are felled too early, the bark strips off easily, perhaps due to the condition of the formative layer of the logs. The formative layer is wide and shows physiological activity before autumn, but later it stops the physiological activity and becomes thin. This change in the autumn probably fastens the bark to the sapwood. In contrast, when trees are felled after all the leaves have turned red, water evaporation through the leaves is prevented, and the natural resistance to shiitake remains and the growth of shiitake mycelia is inhibited.

#### Nutrient amount

The nutritional content of the wood is important for mycelial growth, wood decay, and fruiting. In general, thin logs contain much more nutrition per volume than those of fat logs. Thus thin logs produce fruiting bodies earlier, but with logs less than 5cm in diameter it is difficult to control the water content (Fukuda *et al.*, 1987).

Felling time affects the amount of nutrients of the wood. Logs felled in late autumn have much more nutrition than those felled in early autumn. In general, the nitrogen in green leaves moves to the trunks before the leaves turn red (Tokimoto *et al.*, unpublished). In addition, it is thought that the sugar contents of logs increase as the temperature drops, a process trees initiate to avoid freezing.

In *Quercus* logs, the degree of wood decay and fruiting body yield per 10,000cm<sup>3</sup> in volume negatively correlates with both the diameter and outer bark thickness, but positively correlates with the contents of nitrogen, phosphorus and others (Fukuda *et al.*, 1987; Matsuomoto *et al.*, 1990). In other words, thinner logs and bark are preferred for more wood decay and higher yield, and more nutrition promotes wood decay and shiitake production.

## Strain selection

Table 3. Summarized properties of shiitake strains

	Strain types			
	Low temp.	Low to medium temp.	Medium temp.	High temp.
Maximum temperature for fruiting induction	about 5 ℃	about 10 ℃	about 15 ℃	20-25 ℃
Incubation period for full colonization	Long	Medium or long	Medium	Short
Size and quality of fruiting bodies	Big sized, mainly dried		Medium or big sized, mainly dried	Small or medium sized, consumed fresh

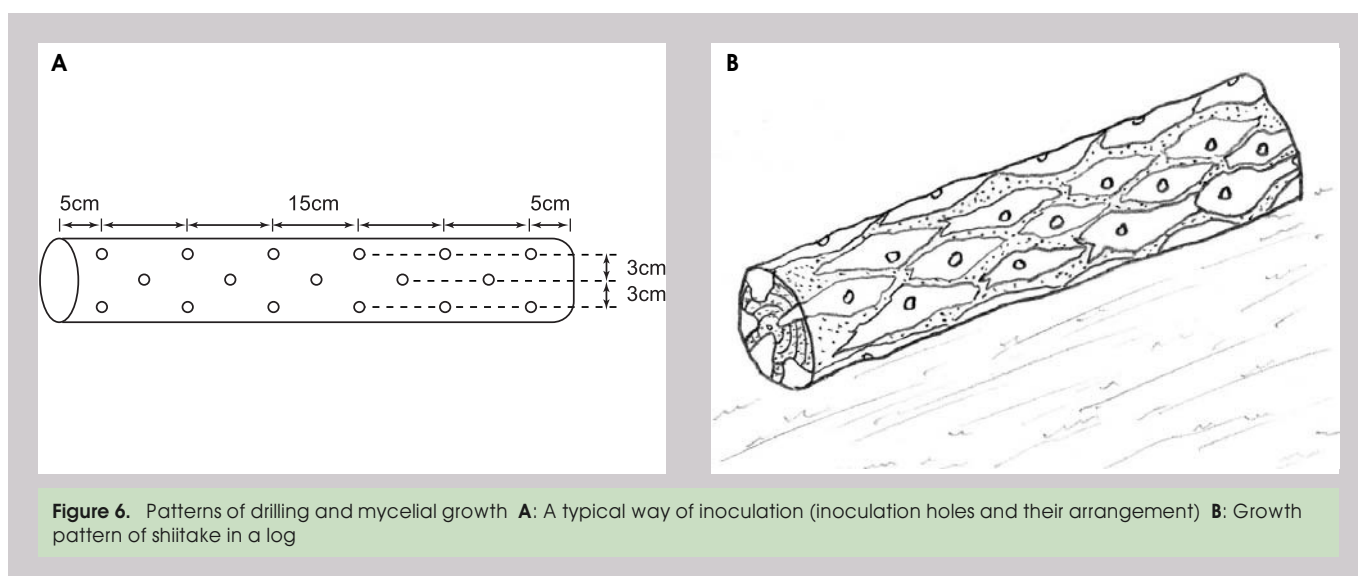
Note: Typical properties are shown, although there are some exceptions.

Shiitake strains are classified according to fruiting temperatures into four types: low, low to medium, medium, and high temperature types (Table 3). Low, low to medium and medium temperature types fruit at lower than about 5, 10 and 15℃, respectively. Many high temperature strains are able to fruit at 20-25℃, but in many cases require soaking the logs in cold water lower than 20℃. For fruiting in summer or warm places, high temperature strains are recommended. Generally, the incubation period of high temperature strains tends to be shorter but their fruiting life ends earlier.

In Japanese and Korean markets, high quality shiitake with larger and thicker caps are dried. Therefore, low or medium temperature types are selected for dried shiitake products because these strains generally produce larger and thicker fruiting bodies than high temperature strains.

## Inoculation

Just prior to the inoculation, thirty to sixty holes, about 2cm in depth, are drilled in a log of average size (Fig. 6A). In many cases, the inoculation holes are spaced at 15-20cm intervals along the longitudinal direction with rows 3-4cm apart. This is because mycelial expansion in the longitudinal direction is almost five times faster than in the circumferential direction (Fig. 6B).



Either sawdust or wooden plug spawn that carries the shiitake mycelium is inserted into the holes. Images of the two types of inoculation of sawdust spawn, a spawning gun and a sawdust plug spawn are shown in Figures 7. A spawning gun is an effective tool for inoculating sawdust spawn into the holes and sealing them. After drilling holes on logs in the suggested patterns, the spawning gun is loaded with sawdust spawn, which is then shot into the holes (Figs. 7A, B, and D). The gun inserts sawdust spawn using compressed air and covers the spawned hole with a styrofoam seal at the same time (Fig.

7C). Sawdust plugs are pre-made for spawning and inoculation is performed by inserting them into the holes in the logs (Fig. 7F). Figure 7E shows the structure of a sawdust plug spawn<sup>2</sup>.



**Figure 7.** Inoculation and equipment **A:** Drill **B:** Drilling holes **C** and **D:** Spawning gun and spawning with it **E** and **F:** Plug spawn and spawning with it

### Spawn run

Inoculated logs are arranged in places where suitable humidity, good drainage, and indirect sunlight are available. Tree shade or shading nets can provide such an environment. Inoculated logs can also be incubated in a growing house. The optimal temperature for mycelial growth is 22-26 °C, while the wood-decay process is stronger at 25-30 °C (Tokimoto *et al.*, unpublished). Direct sunlight to logs must be avoided, because this can raise the log temperature to over 35 °C, which causes

<sup>2</sup> For detailed process of sawdust plug production, see SPAWN PRODUCTION PREPARATION CHIEFLY WITH SAWDUST in chapter 2.

heat damage to the shiitake mycelium. When the temperature is below 15℃ during spawn run, covering of log pile with a plastic film is an effective way to raise the temperature. However, these films must be removed when the outdoor temperature rises above 15℃.

The optimal water content of logs during spawn run is around 35% in wet base, which represents a 5-10% loss from the weight of living fresh logs. In the dry season, watering is effective. Mycelial growth tends to slow in the rainy season because of the excessive supply of water. Occasional screening that protects the logs from rain is used for controlling the water content of logs during the rainy season.

### Log stacking methods

Inoculated logs are re-stacked several times during the spawn run according to the environmental requirements of each growing stage. Several stacking methods such as bulk stack, crib stack, lean-to stack and A-frame stack are used. Each serves in different micro-environments to aid in ventilation and humidity control. Growers should consider their own conditions when choosing a stacking method. In general, well ventilated stacking is recommended for wet logs while low or close stacking is better for dry logs. The main focus of log management should be on the mycelial protection for one or two months after inoculation, on pest and disease control during the spawn run period, and on easy working during the pinning and fruiting periods.



In Korea, with four distinct seasons, growers are advised to stack the logs three times. The stacking methods mentioned here are standard in Korea, but may not be appropriate for another country. As logs are inoculated when it is still cold and dry outside, they are stacked for 1-2 months in such a way as to help the shiitake mycelia start growing. A bulk stack is common for mycelial growth, and this is a very dense stacking (Fig. 8A). The object is to keep the temperature at 10-20℃, and the humidity at 80-90%. When the shiitake mycelia have grown about 20mm along the wood fiber after one or two months, restacking is required. Once the initial shiitake mycelia have grown sufficiently, the logs are stacked to aid in spawn run. Either a crib stack or a lean-to stack is usually used for spawn run (Figs. 8B and C). The logs go through the long spawn run

period over six months that includes both a rainy season and a hot summer. During this spawn run period, pests and diseases, and drainage should be well controlled. When spawn run is almost completed, they are arranged in an A-frame stack and kept in this shape during fruiting and harvesting (Fig. 8D). It is recommended that growers should not arrange logs so closely as to ruin the shiitake's shape. The slant of log stacking affects mycelial growth. In general, a different degree of slant is recommended for log stacking according to the different log species, thickness, weather, drainage, ventilation, and amount of logs (Table 4). The required period for full colonization of logs by shiitake mycelia depends on the spawn run temperature, humidity, strains, the type of spawns, and log properties. For example, some strains of sawdust spawn produce fruiting bodies directly from the spawn holes after about six months' spawn run, but many strains of plug type spawn require more than one year.

**Table 4.** Slant of logs stacking

	Steep	Gentle
Wood species	<i>Quercus acutissima</i> , <i>Q. serrata</i> , <i>Q. mongolica</i> , <i>Q. variabilis</i>	<i>Carpinus laxiflora</i> , <i>Q. myrsinaefolia</i>
Log thickness	Thick	Thin
Weather	Rainy	Dry
Drainage	Bad	Good
Ventilation	Bad	Good
Amount of logs	More	Less

Source: Teaching Material for Shiitake Cultivation in 2002, National Forestry Cooperatives Federation

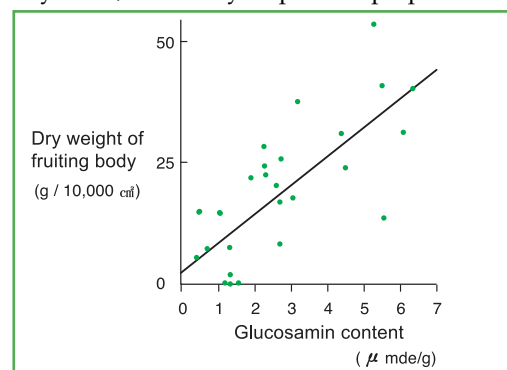
## What makes a good log?

### Importance of mycelial amount in logs

The development of fruiting bodies requires nutrition which is supplied by the vegetative mycelium to the fruiting body. During the development of fruiting bodies, sugars, amino acids, and other chemicals accumulate beneath the young fruiting bodies then move into the fruiting bodies (Tokimoto *et al.*, 1977, 1984). Colonized logs with higher measured chitin content<sup>3</sup> produce greater fruit body yields, because high chitin content indicates abundant mycelial growth (Tokimoto and Fukuda, 1981) (Fig. 10). The logs with well developed mycelia also possess a strong resistance against antagonistic fungi due to their production of antifungal substances (Tokimoto and Komatsu, 1995). However, there is no guaranteed method to encourage mycelial growth. Control of the log water content is important in many cases, and every step in the preparation of the logs affects the subsequent mycelial growth.



**Figure 9.** Well incubated logs seen from above (Lean-to stacks)



**Figure 10.** Relation of glucosamine content to fruiting body yield in shiitake bedlogs (Tokimoto and Fukuda 1981).

Glucosamine, an acid hydrolysate of chitin, was used for the estimation of mycelial amounts in bedlogs. One- to six-year-old bedlogs, 31 samples in total, were employed.  $Y = 5.92^{**}X + 2.59$  (\*\* $P < 0.001$ )

<sup>3</sup> As shiitake mycelium contains fixed amount of chitin, chitin content is useful for the estimation of the mycelial amount. Logs do not have their own chitin.

### Degree of wood-decay

Wood-decay of logs is accompanied by mycelial growth. During cultivation, there is a suitable point of wood-decay which sustains good fruiting. The degree of wood decay is measured by the dry weight of wood, which is calculated by the specific gravity of a log dried in oven. In the case of *Quercus* logs, the specific gravity changes during cultivation from around 0.75, uninoculated logs, to around 0.30, five-year-old logs. A *Quercus* log dried in an oven to a specific gravity of about 0.4 is capable of the best fruiting (Tokimoto *et al.*, 1984). When the fresh weight of a log has decreased by more than 30% before inoculation, the time is generally considered the optimal point of wood-decay. Therefore, it is recommended that fruiting be induced when the logs have lost 30% of their weight.

### Formation of Fruiting Body Primordia



**Figure 11.** Exposed fruiting body primordia beneath the outer bark of a log

A fully incubated shiitake mycelium is ready to change from the vegetative stage (mycelial growth) to the reproductive stage (fruiting). A sudden change of environment is required to trigger the reproductive stage. Lower temperature, higher humidity, and light are the key points of this environmental change. The first step of the reproductive stage is primordia formation. A fruiting body primordium is a tiny mycelial mass, around 2-5mm in diameter, which is formed at the inner bark of logs (Fig. 11). To check the primordium number in logs, the outer barks of several logs are removed as samples. While a sawdust culture fully incubated in darkness requires lighting of 2-3 weeks for primordium formation (Tokimoto and Komatsu, 1982), at least 30 days' lighting is required to produce fruiting body primordia in logs (Komatsu and Tokimoto, 1982).

### Conditions for primordia formation

Fully incubated logs are transferred to a raising yard or growing house where lower temperature, higher humidity and light are provided for primordia formation and fruiting. Primordia formation is an important step because the number of fruiting bodies tends to be equal to the number of primordia. Basically, good logs having well grown mycelia and a proper degree of wood-decay will produce many fruiting body primordia (Tokimoto and Fukuda, 1981).



**Figure 12.** Fruiting area **A:** Raising yard under trees **B:** Simple structure under shading nets

### Temperature

The appropriate temperature for the formation of fruiting body primordia ranges from 15-25 °C, although each strain has its own optimum temperature (Komatsu and Tokimoto, 1982; Tokimoto and Komatsu, 1982). Watering or rain lowers the temperature and also increases the moisture content of logs.

### Moisture content

The water within logs is divided into free water and bound water that is bound to woody cells. Free water plays its part in the mycelial growth and fruiting, while bound water does not. Therefore, free water should be increased within logs to encourage primordia induction. The formation of primordia requires a log water content in which more than 10% (v/v) is free water (Tokimoto, unpublished). Unfortunately it is difficult for growers to determine the amount of free water. However, the weight of logs is an important measure by which farmers can estimate the rough amount of free water. In general, the logs weighing 7kg/10,000cm<sup>3</sup> (equals to logs of 100cm-long and 12cm-diameter) contain more than 10% free water.

### Lighting



**Figure 13.** Fruiting bodies from the holes of sawdust spawn

Sunlight reaching the mycelium beneath the outer bark of logs triggers the formation of primordia. An abundant amount of primordia results in a good shiitake crop.

The minimum luminous intensity for the formation of fruiting body primordia is estimated to be about 0.01-0.001 lux. The inner bark where primordia are formed needs to receive this quantity of light (Ishikawa, 1967). The thickness of the outer bark is important because it prevents light transmission into the mycelium of the inner bark. In the case of *Quercus serrata* logs, the outer bark of more than 2mm in thickness completely prevents both the light transmission and formation of fruiting body primordium (Komatsu and Tokimoto, 1982).

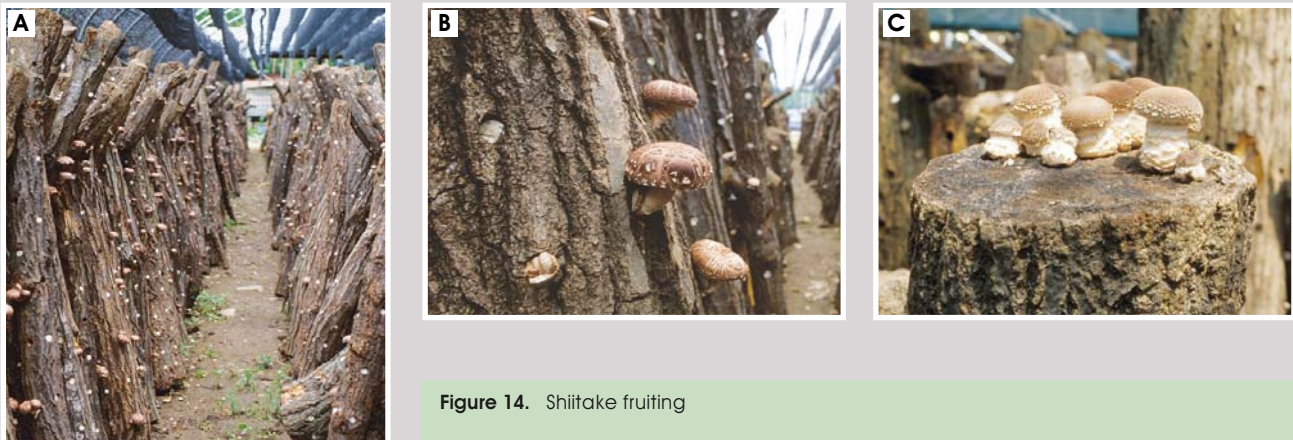
Logs with thick outer bark are not capable of fruiting through the outer bark, but they can fruit directly from the inoculation holes (Fig. 13). The period of light exposure necessary for fruiting may be very short, and may be less than one hour under certain circumstances (Leatham and Stahmann, 1987).

However, it is not always necessary to control the light intensity to induce primordia formation. When 3,000 lux of light is given to logs, even the mycelium beneath the outer bark generally receives several lux of illumination, which is enough to initiate fruiting. In the open air, more than 3,000 lux of illumination is available under trees in most cases.

## Development of Fruiting Bodies

Once primordia are formed, they should develop into fruiting bodies that are large enough to harvest. Fruiting body development is stimulated by low temperatures from 5 to 20°C, depending on the strains and watering. When the temperature is appropriate for the strain, fruiting occurs naturally in autumn and spring. Log beating, which is a physical shock, is also known to be effective in fruiting induction. Many growers soak the logs in cold water at 15-20°C to promote fruiting body development. Soaking process gives logs water and physical shock.

In intensive cultivation, logs of high temperature strains are commonly used. This is because high temperature strains tend to be more sensitive to stimuli and thus more suitable for forced fruiting. These days the majority of shiitake growers cultivate high temperature strains indoors in order to be able to regulate the environmental factors and timing of the mushroom production more easily.



**Figure 14.** Shiitake fruiting

## Conditions for fruiting body development

### Low temperature

Low temperatures induce fruiting body development which accompanies the enhancement of enzyme activities such as acid protease and the accumulation of nutrients around a developing fruiting body (Tokimoto *et al.*, 1984; Tokimoto and Fukuda, 1997). Temperature during fruiting body development also affects the shape and yield of fruiting bodies and each strain has its own optimum temperature (Kawai and Kashiwagi, 1968; Ohira *et al.*, 1982). When the temperature is lower or higher than optimum for the strain, smaller fruiting bodies are produced. High temperature strains are induced to produce fruiting bodies with a shorter exposure of low temperature, and may need only several hours of cold. However, low or medium temperature strains require much longer exposure to low temperature to induce fruiting by exposure to a brief low temperature.

Generally, old and light logs require much more water but young and heavy logs also need a small amount of water. Watering is the most practical way of lowering temperature in summer. Water temperature is also important as is the amount of absorbed water.

### Water content in logs

A relative humidity more than 65% is essential for the normal growth of fruiting bodies (Kawai and Tokimoto, unpublished). Logs consist of wood substance, water (bound water and free water), and air. In *Quercus* wood, the maximum amount of the bound water is around 28% (w/w) of the wood substance, and the remaining amount is free water. In many cases, the free water is about 10-20%, but occasionally it may reach more than 20% after the logs have been soaked in water. The amount of free water depends on the amount of total water which varies with log conditions. The progress of wood-decay reduces wood substance and increases the capacity of free water and air.

Each log has its own optimum water content for fruiting, depending on the degree of wood-decay. In the case of *Quercus* logs, a high content of free water, more than 20%, together with a high content of air volume, more than 30%, results in a good fruiting (Tokimoto *et al.*, 1998) (Table 5). As less decayed young logs have high levels of wood substance, it is difficult to hold high contents of free water and air. That is why less decayed logs produce fewer fruiting bodies. In contrast, old logs easily get much more free water and air but have insufficient nutrients.

**Table 5.** Physical properties in sapwood after soaking and mean yield of 10 logs

Log age (month)	Treatment before soaking*	Volume (%) in sapwood after soaking**			
		Wood substance and bound water	Free water	Air	Fruiting body yield (g)***
21	Cut ends	40.5	20.5	39.0	111
	Notched bark	40.9	23.9	35.5	122
	None	40.1	17.3	42.3	151
45	Cut ends	29.7	32.8	37.7	242
	Notched bark	29.4	32.0	38.6	190
	None	29.4	17.8	52.8	68

\* To promote water absorbance, the both ends of logs were cut off or the outer bark was notched six places per log.

\*\* Per 10,000cm<sup>3</sup> of wood, after 16 hours soaking

\*\*\* Fresh weight, mean of 10 logs

Note: A strain of low to medium temperature type was used.

### Physical shock

Log beating as well as watering promotes fruiting body production. Generally, beating synchronized with watering induces much more fruiting bodies. However, logs soaked in water 24 hours after the beating fruit poorly. When farmers try a second beating after the first beating, the interval of the two beatings is important. The second beating on the day following the first beating shows no effect, but those on the fourth and the eighth days' treatment result in good fruiting. In general, the negative effect of the first beating will remain through the second day and disappear on the fourth and eighth days, although such an interval is changeable with strains and log conditions (Table 6, Tokimoto, unpublished). The mechanism of the effect of physical shock remains unclear.

**Table 6.** Effect of beating and soaking the bedlogs on fruiting body yield

Treatment	Number of fruiting bodies per log
Soaking only	38
Beating and soaking	55
The 1st day's beating, and the 2nd day's beating with soaking	30
The 1st day's beating, and 2nd day's soaking without beating	31
The 1st day's beating without soaking, and the 4th day's soaking with beating	56
The 1st day's beating without soaking, and the 4th day's soaking without beating	32
The 1st day's beating without soaking, and the 8th day's soaking with beating	58
The 1st day's beating without soaking, and the 8th day's soaking without beating	36

Note: Treatments of beating and soaking in the same day were carried out without intervals between them. The period of soaking logs in water was 16 hours.

### Maximum yield from a log

Shiitake cultivation is thought to be a conversion of wood components into fruiting bodies. Comparison of the amounts of elements between *Quercus serrata* wood and the fruiting bodies revealed that the amounts of N, P, and K in the logs limit the fruiting yield. As most of the shiitake growers do not utilize the nutrients of logs sufficiently, an increase in these nutrients may be not important. Addition of these elements to the soaking water promotes fruiting, but it sometimes causes the invasion of antagonistic fungi after fruiting. In addition, shiitake is assumed to always be cultivated without chemicals in Japan. Thus, addition of extra elements is not recommended. On the supposition that spent logs contain these elements at the amount of 20-30% of the un-inoculated logs, a log of 10,000cm<sup>3</sup> in volume could produce about 2.5kg of fresh fruiting bodies in the course of its whole life (Tokimoto *et al.*, 1982; Matsumoto *et al.*, 1990).

## Harvest and Management

### Cropping and fruiting cycle



Figure 15. Joy of shiitake harvest

Shiitake is harvested when the fruiting bodies grow large enough to harvest. Cropping time depends on which type of shiitake the market prefers. Shiitake is harvested early if closed cap is preferred and late if open cap is preferred by the consumers. From the point of nourishment, the most desirable cropping time of fruiting bodies is in the middle or later stage of development. The quantities of many components including sugars and polysaccharides are constant or increase slightly during development (Yoshida *et al.*, 1986). Lentinan, an anti-tumor substance of shiitake, is present in higher quantities during the middle stage of development (Minato *et al.*, 2001). Fruiting bodies harvested in the middle stage of development are able to be preserved for longer than those harvested during the later stages. As fruiting body production uses a great deal of energy, the mycelia in the logs

require a rest of more than one month between one flush and the next flush. A temperature of 15-25 °C and watering may shorten the recovery period.

### Storage of fresh shiitake

The quality of harvested shiitake drops quickly at room temperature as brownish pigmentation increases in bad smell and decreases in the amount of sugar, polysaccharides, and others (Minamide *et al.*, 1980a; Yoshida *et al.*, 1986). To escape this deterioration, a low temperature treatment is the most applicable. The shelf life of fresh shiitake is about 3 days at 20 °C but can be 14 days at 6 °C (Minamide *et al.*, 1980b). In addition, storage in a controlled atmosphere (CA) is effective. Forty percent CO<sub>2</sub> with 1-2% O<sub>2</sub> is shown to be a good condition for maintaining shiitake freshness. The shelf life of shiitake could be extended 4 times in kept at 20 °C as compared to non CA-treated shiitake (Minamide *et al.*, 1980a). Cold treatment and CA treatment slow down the decrease of useful substances such as lentinan within shiitake (Minato *et al.*, 2001; Kawakami *et al.*, 2004).

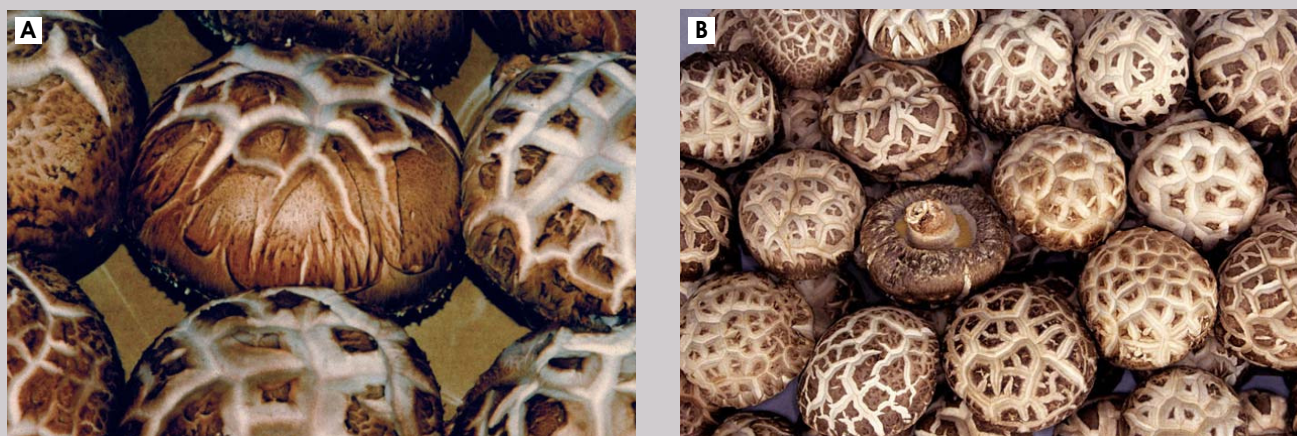


Figure 16. Harvested shiitake A: Fresh shiitake B: Dried shiitake

### Drying shiitake

One of the most commonly used preserving methods for shiitake is drying. The manner in which they are dried can affect the quality of dried shiitake. The fundamental principle of drying is using "a short period with the temperature not too high." This is achieved by using a current of dry air at 30-50°C. The temperature to be given to shiitake depends on the water content of the fruiting bodies being treated. Lower air temperatures are used for wetter fruiting bodies. Faster drying produces less shrunken shiitake (Kawai, 1962). However, when the surface temperature of the fruiting bodies rises over 30-35°C in the first five hours of drying, the dry shiitake turn black and become very small (Kawai and Kawai, 1961).

### Conclusion

Log cultivation of shiitake can be described as a process whereby the log components are converted to edible shiitake under natural environmental conditions. The methods of shiitake cultivation have improved according to the variable environmental conditions, and each country or region tends to have its own best methods. It is essential to understand the biological nature of shiitake and observe the logs carefully in order to adopt the suitable management measures as well as the appropriate cultivation method.

### REFERENCES

- Brauer, D., T. Kimmons, and M. Phillips. 2002. Effects of management on the yield and high-molecular-weight polysaccharide content of shiitake (*Lentinula edodes*) mushrooms. *J. Agric. Food Chem.* 50: 5333-5337.
- Fukuda, M., K. Tokimoto, M. Tsuboi, and Y. Nishio. 1987. Relation of properties of logs to the rate of wood decay and fruitbody yield in cultivation of *Lentinus edodes*. *Rept. Tottori Mycol. Inst.* 25: 68-74.
- Ishikawa, H. 1967. Physiological and ecological studies on *Lentinus edodes* (Berk.) Sing. *J. Agr. Lab.* 8: 1-57.
- Kawai, A. 1962. On the relation between the drying speed and the shrinkage during the drying of fruit-bodies of *Lentinus edodes* (Berk.) Sing. *Rept. Tottori Mycol. Inst.* 2: 27-30. (In Japanese)
- Kawai, A., and J. Kashiwagi. 1989. Relation of temperature to yield of fruitbodies of shiitake, *Lentinus edodes* (Berk.) Sing. *Rept. Tottori Myc. Inst.* 6: 43-48.
- Kawai, W., and A. Kawai. 1961. Studies on Nietsuki production during the drying of fruit-bodies of *Lentinus edodes* (Berk.) Sing. *Rept. Tottori Mycol. Inst.* 1: 29-34.
- Kawakami, S., K. Minato, K. Tokimoto, N. Fujita, M. Mizuno. 2004. Changes of lentinan contents and glucanase activity in *Lentinus edodes* (Berk.) Singer (Agaricomycetidae) stored under controlled atmosphere. *Intern. J. Med. Mushrooms* 6: 57-62.
- Komatsu, M., Y. Nozaki, A. Inoue, and M. Miyauchi. 1980. Correlation between temporal changes in moisture contents of the wood after felling and mycelial growth of *Lentinus edodes* (Berk.) Sing. *Rept. Tottori Mycol. Inst.* 18: 169-187.
- Komatsu, M., and K. Tokimoto. 1982. Effect of incubation temperature and moisture content of bed-logs on primordium formation of *Lentinus edodes* (Berk.) Sing. *Rept. Tottori Mycol. Inst.* 20: 104-112.
- Korea Forest Service. 2003. *Statistics on Forest Products in 2003*.
- Leatham, G., and M. Stahmann. 1987. Effect of light and aeration on fruiting of *Lentinula edodes*. *Trans. Br. mycol. Soc.* 88: 9-20.
- Lee, E.R. 1978. Studies on the possibility of oak mushroom (shiitake) cultivation on Ban Oak (*Quercus incans*) of India. *Korean J. Mycol.* 6: 31-35.
- Matsumono, T., K. Tokimoto, M. Fukuda, and M. Tsuboi. 1990. Contents of mineral elements in *Quercus serrata* logs: variation with the felling time and

- their effects on the fruitbody yield of *Lentinus edodes*. *Rept. Tottori Mycol Inst.* 28: 325-332.
- Minato, K., M. Mizuno, S. Kawakami, S. Tatsuoka, Y. Denpo, K. Tokimoto, and H. Tsuchida. 2001. Changes in immunomodulating activities and content of antitumor polysaccharides during the growth of two medicinal mushrooms, *Lentinus edodes* (Berk.) Sing., and *Grifola frondosa* (Dicks.:Fr.) S. F. Gray. *Intern. J. Medic. Mushrooms* 3: 1-7.
  - Minamide, T., T. Nishikawa, and K. Ogata. 1980a. Influences of CO<sub>2</sub> and O<sub>2</sub> on the keeping freshness of shiitake (*Lentinus edodes* (Berk.) Sing.) after harvest. *Nippon Shokuhin Kogyo Gakkaishi* 27: 505-510.
  - Minamide, T., Tsuruta, M., and Ogata, K. 1980b. Studies on keeping freshness of shii-take (*Lentinus edodes* (Berk.) Sing.) after harvest. *Nippon Shokuhin Kogyo Gakkaishi* 27: 498-504.
  - National Forestry Cooperatives Federation. 2002. *Teaching Material for Shiitake Cultivation in 2002*. 32 pp.
  - Ohira, I., Matsumoto, T., Okubo, M., Maeda, T., and Yamane, K. 1982. Effects of temperatures on the yield and shape of *Lentinus edodes* fruitbodies. *Rept. Tottori Mycol. Inst.* 20: 123-139.
  - Przybylowicz, P., and J. Donoghue. 1990. *Shiitake Growers Handbook*. Dubuque, Iowa: Kendall/Hunt Publishing Company. pp. 217.
  - Shimomura, N., and K. Hasebe. 2004. Estimation of viability of inner bark tissue of *Quercus serrata*, a substrate for log cultivation of *Lentinula edodes*, using the TTC assay method. *Mycoscience* 45: 362-365.
  - Tokimoto, K., and M. Fukuda. 1981. Relation between mycelium quantity and fruit-body yield in *Lentinus edodes* bed-logs. *Taiwan Mushrooms* 5: 1-5.
  - Tokimoto, K., and M. Fukuda. 1997. Changes in enzyme activities in bedlogs of *Lentinula edodes* accompanying fruit body development. *Mokuzai Gakkaishi* 43: 444-449.
  - Tokimoto, K., and M. Komatsu. 1982. Influence of temperature on mycelium growth and primordium formation in *Lentinus edodes*. *Trans. Mycol. Soc. Japan* 23: 385-390.
  - Tokimoto, K., and M. Komatsu. 1995. Selection and breeding of shiitake strains resistant to *Trichoderma* spp. *Can. J. Bot.* 73: S962-S966.
  - Tokimoto, K., A. Kawai, and M. Komatsu. 1977. Nutritional aspects of bed-logs of *Lentinus edodes* (Berk.) Sing. during fruit-body development. *Rept. Tottori Mycol. Inst.* 15: 65-69.
  - Tokimoto, K., T. Hiroi, A. Nishida, A. Tamai, and M. Fukuda. 1982. Changes of bed-log components and fruit-body yield during *Lentinus edodes* cultivation. *Rept. Tottori Mycol. Inst.* 20: 117-122.
  - Tokimoto, K., M. Fukuda, and M. Tsuboi. 1984. Physiological studies of fruitbody formation in bedlogs of *Lentinus edodes*. *Rept. Tottori Mycol. Inst.* 22: 78-79.
  - Tokimoto, K., M. Fukuda, and M. Tsuboi. 1998. Effect of the physical properties of *Lentinula edodes* bedlogs on fruiting body production. *Mycoscience* 39: 217-219.
  - Triratana, S. 1993. Shiitake production in tropical Thailand. In: *Proc. Intern. Shiitake Mushroom Symposium in Oita* pp. 157-165.
  - Yoshida, H., T. Sugahara, and J. Hayashi. 1986. Changes in the contents of carbohydrates and organic acids in fruit-bodies of shiitake-mushroom (*Lentinus edodes* (Berk.) Sing.) during development and post-harvest storage. *Nippon Shokuhin Kogyo Gakkaishi* 33: 414-425.

## Part I Shiitake

## Chapter 3

Shiitake Log Cultivation

## SHIITAKE LOG CULTIVATION IN BRAZIL

Maria Catarina Kasuya<sup>1</sup>, Maria Cristina Vanetti<sup>1</sup>, Akihiko Manabe<sup>1</sup>,  
Cristiane de Castro Santana<sup>1</sup> and Margarida de Mendonça<sup>2</sup>

<sup>1</sup>Universidade Federal de Viçosa, Departamento de Microbiologia, Viçosa, Minas Gerais 36570-000, Brazil \*(mkasuya@ufv.br) <sup>2</sup>Federal Univ. Santa Catarina, Brazil

## Introduction



**Figure 1.** Major geographic regions in Brazil (Northern, Central-Western, Northeast, Southeast and Southern) and localization of main shiitake growers (both log and bag cultivation)

Traditionally, Brazilian people do not consume edible mushrooms. It is estimated that the annual consumption in Brazil is only from 30-60g per capita, while the per capita consumption is 3.5kg in Germany, 2kg in France, 1.6kg in the US and 1.3kg in Italy. About 60% of the national production in Brazil is consumed as fresh mushrooms, and the other 40% is used by the food processing industry. In recent history, the consumption of mushrooms has increased, largely due to the fact that they have started to be considered as healthy, fresh, and nutraceutical food products. These new concepts of health and “healing” food have increased the interest in the commercial exploitation of shiitake in Brazil since 1980. Today, shiitake and other mushrooms are produced in several different states of the country (Fig. 1).

The main mushroom growers are concentrated in the south and southwestern regions due to climatic conditions, the high concentration of Oriental immigrants there, and the higher socioeconomic development in those regions. Although shiitake culture is not typically common in hot climates, several strains have been selected and shiitake

production with these selections has shown good results.

*Agaricus bisporus* is the most produced and commercialized mushroom in Brazil, followed by shiitake, oyster mushroom, and *Agaricus blazei*. Mushroom production is generally performed on a small scale, most frequently as an alternative crop by which small farmers can diversify their agricultural production and increase their income. Due to its easier cultivation, the growing market and the low initial cost of investment, shiitake cultivation is more frequently being considered as an alternative crop. The number of shiitake farmers is increasing, and growers and investors across the country have become interested in the production of this mushroom.

For individuals interested in production as a hobby or for limited local sale, shiitake growing can be quite rewarding. Commercial production, however, requires a substantial commitment of time and money. As with any agricultural commodity, profits depend on the grower's production and marketing skills, as well as on market supply and demand. The technology and information on the economics of production in Brazil is still in the early stages of development.

## Shiitake Log and Inoculation

In Brazil, *Eucalyptus* logs are the most common tree species used for shiitake cultivation. *Eucalyptus* is cultivated throughout

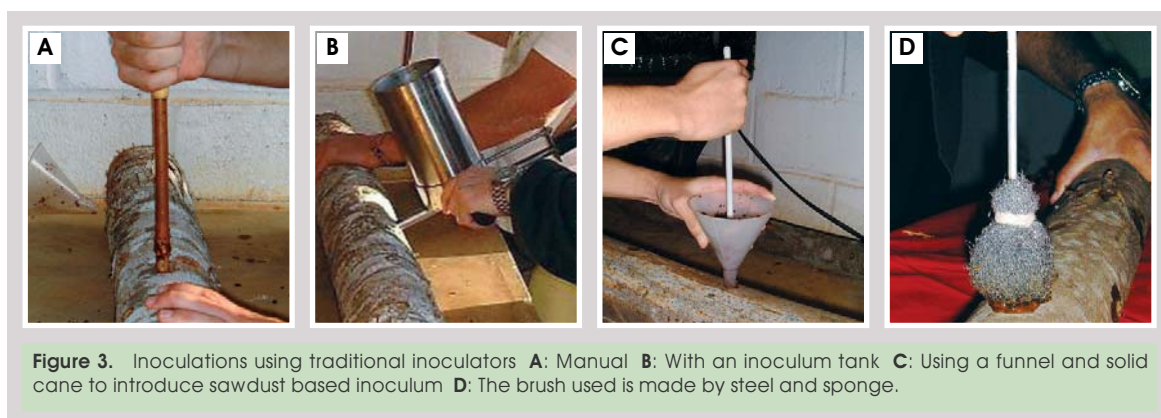
Brazil, and is faster growing and less expensive than other tree species. *Eucalyptus* logs can be harvested four to six years after planting. There is not much information comparing the various eucalyptus species, but on average the productivity is about 0.6-1.5kg per log life of 12-14 months. The main species of *Eucalyptus* used for shiitake cultivation are *E. grandis*, *E. saligna*, *E. urophylla* and their hybrids. *Eucalyptus citriodora* has also been used but it has been refused by some producers because of its strong odor, as this is the wood that produces the essence commonly used in sauna and room deodorant sprays. The bark of *E. citriodora* is also thinner and smoother than other *Eucalypt* species, which results in greater log dehydration (Figs. 2).

The dehydration delays mushroom growth and therefore the productivity of shiitake is lowered. Logs of other tree species, such as avocado, ipezinho, and acacia have been tested on a small scale, and have shown some positive results, but unfortunately, no scientific data has been recorded.



**Figure 2.** Eucalyptus logs **A:** Logs of *Eucalyptus citriodora* showing a thin and smooth bark **B:** *Eucalyptus grandis* presents a thick and rough bark

After using special drills to make the holes, inoculation is done manually, employing either inoculators or funnels. To use a manual inoculator, a farmer will fill it with sawdust-based spawn, and then push a piston in the top of the inoculator to insert the spawn into the hole (Fig. 3A). When using the second type of manual inoculator, sawdust-based spawn is put in a tank of about 500g, and then a lateral piston in the base of the tank is activated and makes a horizontal movement that inserts the spawn into the hole (Fig. 3B). The funnel method also uses a sawdust spawn. In this case it is put into the funnel and then introduced into the hole using a solid cane of plastic, aluminum or wood (Fig. 3C). In all cases, the filled holes are then sealed with a sealing sponge and a mixture of 80% paraffin and 20% pitch (Fig. 3D).



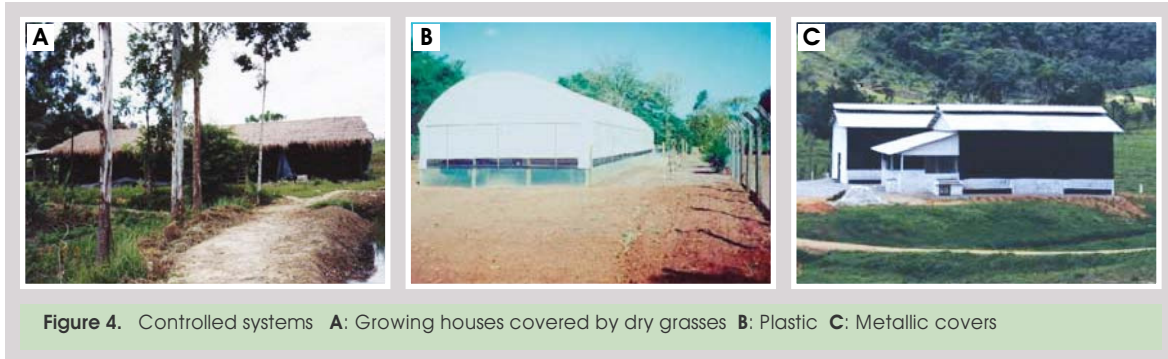
**Figure 3.** Inoculations using traditional inoculators **A:** Manual **B:** With an inoculum tank **C:** Using a funnel and solid cane to introduce sawdust based inoculum **D:** The brush used is made by steel and sponge.

### Growing conditions

Brazilian shiitake growers incubate logs both in open systems under trees or under net shade and in controlled systems inside acclimatized buildings. The open incubation systems have many problems due to the high incidence of birds and insects such as ants and termites, and the difficulty of uncontrollable climatic conditions. To solve these problems, growing houses are covered by dried grasses, plastic, or metallic panels (Figs. 4). These houses offer greater climatic controls but most of them have only a top cover and some lateral protection using plastic sheeting or nets.

After inoculation, logs are usually incubated using the crib stack as shown in the Figures 5A and B, but some farmers gather inoculated logs together and maintain them under plastic film (Fig. 5C). The method shown in Figure 5C maintains humidity

more effectively, thereby diminishing the frequency of required irrigations and enhancing the mycelial growth rate. However, the maintenance of humidity above 95% in association with high temperatures, favors the growth of competitor fungi, such as *Trichoderma*.



Brazil is a large country and climatic conditions are quite variable. The zones where shiitake is cultivated have average temperatures ranging from 20 to 30 °C and relative air humidities from 60 to 90%. In central Brazil, the relative humidity is very low and the winds are strong, but growers in this region have cultivated shiitake in controlled conditions that increase the humidity and offer protection from the wind. In others parts of the country the winters are cold and dry while the summers are hot and humid. This climate allows for the cultivating of shiitake practically all year long although high productivity is only possible in winter periods. The productivity varies from 600 to 1,500g per log. The logs are 1m long and 12-15cm of diameter on average. The first flush occurs 3-8 months after the spawn run, with variations according to the tree species, fungal isolate and temperature. Where the temperatures are low, the spawn run periods are longer, and where the temperatures are higher, the spawn run periods are shorter. The shiitake cultivated have shown different colors and morphological aspects, but in general, Brazilians prefer the light-colored mushrooms (Figs. 6).

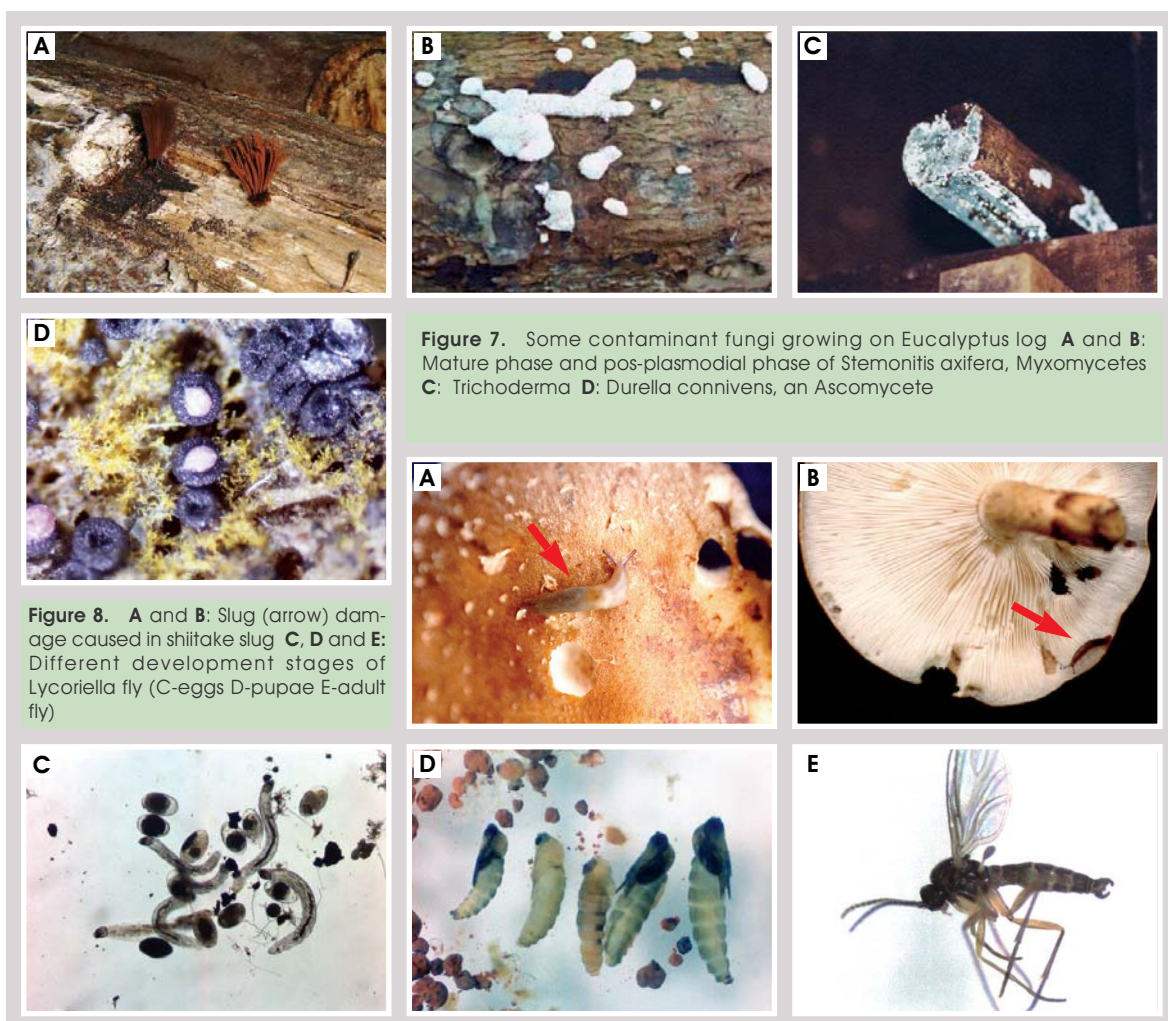


### Pests and diseases

A number of diseases can destroy growing shiitake or compete with them for nutrients. Some insects and animal pests can also reduce yields or quality. Insects that might present a problem for the Brazilian producers of shiitake in logs include ants, termites, springtails, lizards, and some *Lepidoptera* and *Coleoptera* beetles and moths. These pests attack logs during the phases of spawn running and fructification and they feed on the mycelium or compete for the space and substrate with shi-

itake mycelium. The most frequent fungal contaminants in *Eucalyptus* logs are *Stemonitis axifera*, *Trichoderma*, *Schizophyllum*, and *Hypoxylon* (Figs. 7).

Shiitake has been also attacked by slugs and ants and the larvae of mushroom flies (Figs. 8). Birds also feed on shiitake. The usual recommendation for the producers of mushrooms is to use preventive control of plagues and diseases instead of any agrochemical products. Natural methods of control are encouraged, such as the use of citronella oil, and luminous traps or fruit juices traps for the control of flies. Beer traps are used for the control of slugs. Neem<sup>1</sup> is also often used as biological insecticide. Despite the availability of these natural methods, some producers still use chemical insecticides.



**Figure 7.** Some contaminant fungi growing on Eucalyptus log **A** and **B**: Mature phase and pos-plasmodial phase of *Stemonitis axifera*, **C**: *Trichoderma* **D**: *Durella connivens*, an Ascomycete

**Figure 8.** **A** and **B**: Slug (arrow) damage caused in shiitake **C**, **D** and **E**: Different development stages of Lycoriella fly (C-eggs D-pupae E-adult fly)

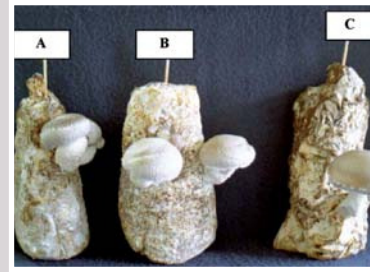
## Comparison with Bag Cultivation in Brazil

In Brazil, few shiitake producers use the process of bag cultivation because it is a highly specialized process that must be conducted in buildings with tight control of temperature, light, and moisture, and also includes the need to acquire an autoclave and boiler for substrate sterilization (Figs. 9). The risk of contamination and loss is much higher with substrate bags than with natural logs, particularly for inexperienced growers. Moreover, there is also the difficulty of finding the specific plastic bags required for this type of culture. It is usually necessary to import them, which increases the production costs. In addition, it is still difficult to obtain shiitake spawn appropriate for bag cultivation in the local market. However, because of the shorter production time and the possibility of exploitation of lignocellulosic wastes, the culture of shiitake in bags has captured the interest of many producers. The main substrates for bag cultivation of shiitake are lignocellulosic wastes, including wood sawdust and agricultural wastes, as cereal straws and the sugarcane bagasse that is abundant in Brazil. Additionally, corncobs and eucalyptus barks have also been tested and showed great potential (Cavallazzi *et al.*, 2003; Santana *et al.*, 2003) (Fig. 10).

<sup>1</sup> neem: an Indian tree, whose leaves have been used to extract some substances and used in biological control



**Figure 9.** Equipment for substrate sterilization for bag cultivation **A:** Boiler **B:** Autoclave



**Figure 10.** Shiitake (UFV-73) on substrate after 60 days of spawn run **A:** Eucalyptus sawdust **B:** Corncob **C:** Eucalyptus bark

## Market of Shiitake in Brazil

Marketing of shiitake in Brazil is a relatively new business. Local buyers and outlets for the small-scale shiitake producers include restaurants, bed and breakfasts, vacation resorts, organic retailers and markets, supermarkets, and farmers markets. As more consumers become aware of the special culinary characteristics of shiitake, demand is likely to increase. In the producer market, 1kg of fresh shiitake in bulk varied from USD3-4, USD4-5 when packed and USD15-17 per kg when dehydrated. In the supermarkets and stores, fresh shiitake can be purchased for about USD8-17 per kg.

The basic production cost, not including money spent on water, energy, housing, machinery and human labor, is about USD882 per 1,000 logs (Table 1). Each log produces 0.6-1.5kg of mushrooms, so the harvest from 1,000 logs is about 600-1500kg for 12-14 months. If bulk fresh shiitake is sold for USD3.50 per kg, the earnings are then from USD2,100-5,250. So the net income can be from USD1,218-4,368 per 1,000 logs for 12-14 months.

Feasibility study of the shiitake cultivation considering a cycle of 14 months was carried out by a group of São Paulo State using 1,000, 2,000, 3,000 and 4,000 *Eucalyptus* logs. The production scales of 2,000 and 4,000 logs presented the lower production costs per kg of fresh mushroom, around USD3.25 and the highest profits, approximately 34%. The economic viability analysis was proven favorable for the greater production scales, with the best results for 2,000 logs and 4,000 logs (Paula *et al.*, 2001). This cost is increasing since *Eucalyptus* logs have mainly been used as charcoal by steelworks, and new types of wood have been looked at for shiitake cultivation. The formation of grower cooperatives and year-round producers has been increased and can greatly aid in the process of helping small producers to deliver reliable, fresh supplies of mushrooms to the market.

## Transfer of Mushroom Cultivation Technology

Annually, during FARMER WEEK that takes place at the Federal University of Brazil, more than 1,000 farmers get together to participate in some 250 courses offered by professionals of this institution. Since 1986, one of these courses has been "Shiitake cultivation in *Eucalyptus* logs" (Figs. 11). The course and training related to production and processing of shiitake are offered at the University or in the cities when they are requested by associations or cooperatives of agricultural producers.

**Table 1.** The basic cost with accessories needed for shiitake logs cultivation (1,000 logs)

Item	Quantity	Value in USD
Inoculators	5	130
Spawn (1 l / 10 logs)	100	190
Paraffin (1 l / 30 logs)	34	65
Pitch (0.20kg / 30 logs)	6	12
Logs	1,000	300
Drill (drill bit)	2	65
Driller	1	120
Total cost		882



**Figure 11.** Aspects of a course in the "Farmer Week" **A:** Participants making holes **B:** Inoculating **C:** The participating group

## Conclusions

Mushrooms have become one of the most exciting new crops in Brazil and their cultivation offers an opportunity for both small and large agriculture operations in Brazil. The demand for shiitake is increasing, and the mushrooms are becoming popular among Brazilian people. Mushroom culture will be a common activity in the future, because fungi-forming mushrooms can utilize many potential agricultural and industrial wastes that could be pollutants, and transformed into high quality food. In the future this industry will feed poor peoples, even though at the moment mushrooms are eaten mainly by rich people in Barzil.

## REFERENCES

- Cavallazzi, J.R., M.S. Brito, M.G.A. Oliveira, S.G.V. Boas, and M.C.K. Kasuya. 2004. Lignocellulolytic enzymes profile of three *Lentinula edodes* (Berk) Pegler strains during cultivation on eucalyptus bark based medium. *Journal of Food Agriculture and Environment* 2(1): 291-297.
- Kasuya, M.C.M., M.C.V. Vanetti, C.C. Santana, A. Manabe, and M.M. Mendonça 2004. Desenvolvimento de tecnologia para produção e processamento de cogumelos shiitake para agroindústria familiar (technical report).
- Paula, D.P., M.A.A. Tarsitano, and L.A. Gracioli. 2001. Viabilidade econômica do cultivo de shiitake em diferentes escalas de produção. *Sci. Agric.* 58: 431-436.
- Santana, C.C., M.C.M. Kasuya, and M.C.D. Vanetti. 2004. Production of shiitake (*Lentinula edodes*) mushrooms in lignocellulosic residues. available at <http://www.mushworld.com>

## Part I Shiitake

## Chapter 3

Shiitake Log Cultivation

## SHIITAKE LOG CULTIVATION IN NEPAL

Keshari L. Manandhar

Center for Agricultural Technology Bijuwari, Kathmandu, Nepal (pkm@ccsl.com.np)

**Background**

Wild shiitake is known as “Mrige Chyau” in Nepal and the name means “deer mushroom.” Perhaps the name comes from the look of a deer or its skin. Traditionally, the people of Nepal collect wild mushrooms from the forest during the rainy season for their own consumption as well as for sale. Shiitake accounts for about 5% of the collected wild mushroom crop. The wild edible mushrooms are sold on the street and in the markets of Kathmandu in locally made bamboo baskets that are good for keeping wild mushrooms fresh for a longer period. The price for a small basket full of mushrooms is very low. The people in the city are fond of wild mushrooms, and there are frequent incidences of mushroom poisoning. Poisoning reports are common from the hospitals, with between 100 to 120 cases appearing per year per hospital. The villagers usually recognize the edible mushrooms from the knowledge inherited from their parents or neighbors. Among these wild mushrooms shiitake used to be one of the most common varieties. However, wild shiitake is getting hard to find these days, perhaps due to a lack of wood logs lying on the forest ground. Local people now collect the logs and use them for fuel.

In research involving shiitake cultivation, a Japanese volunteer named Naoaki Watanabe initiated an experiment in the Division of Plant Pathology (NARC) in 1979 and got successful results from *Quercus* logs. Mr. Kanagawa had also grown shiitake on Celtic tree logs with equally good results. However this particular shiitake cultivation technology could not be used by Nepalese farmers due to the general low availability of those trees. As a result, most all shiitake cultivation technology knowledge remained hidden within the Division of Plant Pathology. Recently the situation within the forestry department has changed and the community forestry program has made great progress and been extended to include forest conservation, management, utilization programmes which are in the hand of forest users groups (FUG). As shiitake cultivation needs wood logs, it is appropriate now to integrate shiitake cultivation into the community forestry programmes. The author has particular hopes that such a programme will be started and well developed in the near future.

**Preliminary Investigation**

An initial feasibility study was carried out before beginning a closer investigation into shiitake cultivation. Local mushroom growers had been growing white button mushrooms and oyster mushrooms for last 20-25 years and this experience was highly beneficial. These farmers have recently requested a new type of mushroom that they might grow for commercially in order to realize a higher income. The community forestry program in Nepal is well organized and has formed FUG for forest conservation, management and utilization. There is now a demand for non-timber forest products and shiitake log cultivation has been found to be one of the best new options.

Anticipating the farmers' need, the Centre for Agricultural Technology (CAT) initiated a research project concerning shiitake log cultivation in the year 2000 under the support of Hill Agriculture Research Program (HARP). This was the first recent investigation of shiitake cultivation in Nepal. Potential mushroom growers are small scale farmers so they can not afford to invest much for mushroom cultivation. There is no big mushroom industry in Nepal, but there are a large number of small scale mushroom farmers. Therefore, it was concluded that shiitake log cultivation was an appropriate method for

these small farmers because shiitake bag cultivation requires a larger initial investment than log cultivation. It was certain that the farmers wouldn't invest much because they were not yet confident of the success in their shiitake cultivation operations. In this regard, it was decided that the most common and fastest growing tree species should be identified. Ideally the trees would be available everywhere and be the cheapest among the wood logs available from different trees species. The identification of locally available fast growing tree species would make it possible to grow shiitake on wood logs in Nepal.

The main objective of this investigation was:

1. To identify the locally available fast growing tree species that were appropriate for shiitake log cultivation
2. To find out the appropriate technology, mountain area locations, and climate for the growth of shiitake



Figure 1. Map of Nepal (location of experiment marked)

This research work was initiated in August 2000 by growing shiitake on wood logs of 18 different tree species. The experiment was carried out at three locations including Chhampy (1,540m) in the Lalitpur district of Kathmandu valley, Devitar (1,300m) in the Kavre district of Kathmandu valley and Lumle (1,600m) in the Pokhara valley located in Western Nepal. These locations are chosen for their cool and humid climate as well as their being the nearest locations to the big markets of Kathmandu and Pokhara. The tree species used at the three locations are shown in Table 1.

Table 1. Tree species used in experiment to choose appropriate shiitake log

Location	Chhampy	Devitar	Lumle
Tree species	<i>Alnus nepalensis</i> *	<i>Faxinus floribanda</i> *	<i>Daphniphyllum himalensis</i>
	<i>Castanopsis indica</i> *	<i>Betula alnoides</i> *	<i>Castanopsis hystrix</i> *
	<i>Prunus serasoides</i>	<i>Alnus nepalensis</i> *	<i>Engelhardtia spicata</i>
	<i>Betula alnoides</i> *	<i>Castanopsis species</i> *	<i>Macaranga pastulata</i> *
	<i>Juglans regia</i>		<i>Alnus nepalensis</i> *
	<i>Schima wallish</i>		<i>Celtis australis</i> *
	<i>Spondia axillaris</i>		<i>Betula alnoides</i> *
	<i>Pinus walachina</i>		<i>Quercus delata</i> *
	<i>Quercus semicarpifolia</i> *		
	<i>Quercus trifolia</i> *		

\* Tree species that was able to produce shiitake

Among the tested tree species, *Alnus*, *Betula* and *Castanopsis* were found to be most common in many parts of the country. *Alnus* grows naturally on river banks, on exposed land in mountainous landslide areas, and on waste land in the agricultural and watershed areas. These trees usually grow in sandy soil and are available from the eastern to western part of the country. *Alnus* is a fast growing tree with soft wood. Farmers usually grow them on their wasteland and in private forests for their own consumption as a timber and fuel wood. A five-year old *Alnus* tree is just the appropriate size to cut down for shiitake cultivation. From such a tree there may be nine to ten pieces of one-meter long log with a diameter between 5-15cm. In general one tree cost NPR<sup>1</sup> 250-300 (USD3.47-4.16). *Alnus* trees are also used for sheltering tea plantations and cardamom farms. CAT has recommended *Alnus*, *Betula* and *Castanopsis* trees be used for shiitake cultivation. The shiitake production data from 3 different tree species and 4 different strains are given in Table 2.

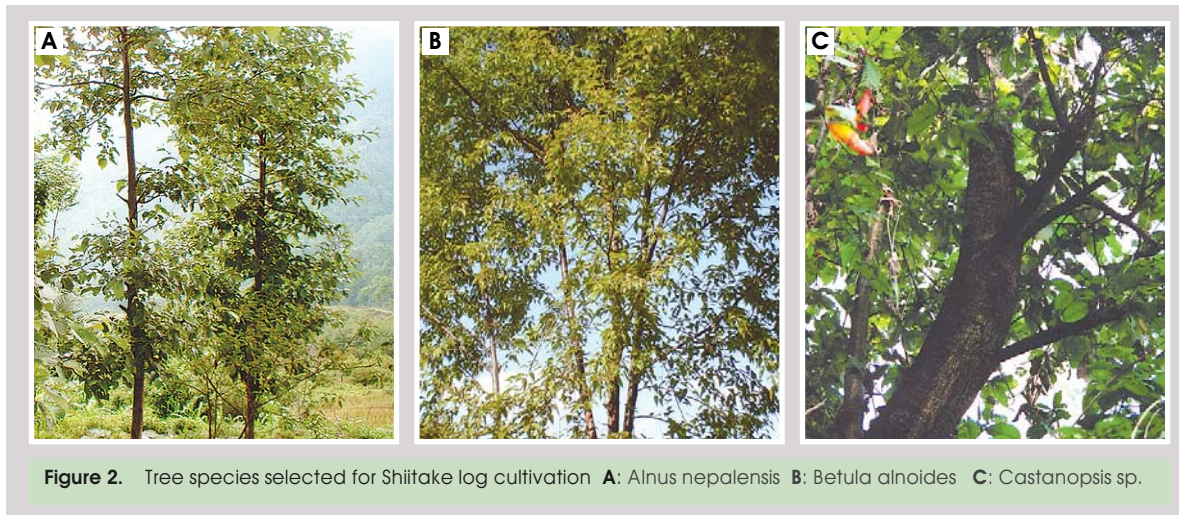
The shiitake strains used for the research work were mostly Japanese strains such as Mori 121, Mori 290 and Meiji. Some wild strains from Nepal were also tested but the fruiting bodies were found to be thin and small in size. Two other strains, one each from Malaysia and Bhutan, were also tested but the Mori strains were determined to be the best and most suitable for the climate of Nepal.

<sup>1</sup> NPR (Nepalese Rupee, USD1 = NPR72.05 in March, 2005)

**Table 2.** Average yield of 4 strains from logs of three tree species (g)

Shiitake strain	<i>Alnus</i>	<i>Betula</i>	<i>Castanopsis</i>
Mori 121	3,590	2,650	4,620
Mori 290	4,970	1,600	2,360
Mori 465	1,610	1,860	2,360
Meiji 410	1,860	1,360	1,720

Note : The yield was estimated from 8 logs for a year



**Figure 2.** Tree species selected for Shiitake log cultivation **A:** *Alnus nepalensis* **B:** *Betula alnoides* **C:** *Castanopsis* sp.

Further research has continued to investigate the timing of wood log cutting and the appropriate periods for wood log drying under different seasons and situations. It will also be necessary to know whether log inoculation can be done all year round or not and the various cost benefit ratios are still to be worked out.

## Production Process

The wood logs are cut down in December when the average temperature is 19-22 °C and humidity 70-80% (Fig. 3A). The logs are piled up in a heap and dried under shed for a period of one month. The ideal size of the wood logs is one meter long and 10-15cm in diameter. These wood logs are cut carefully so as not to damage the bark and also handled carefully during the operation.

In January when the average temperature is 19-22 °C and humidity 70-80%, these logs are inoculated using shiitake sawdust spawn. The holes are drilled at a distance of 15-20cm and the size of the holes is 1.5cm in diameter and 2cm deep (Fig. 3B). The inoculation is done by hand and sealed with paraffin wax (Figs. 3C and D).



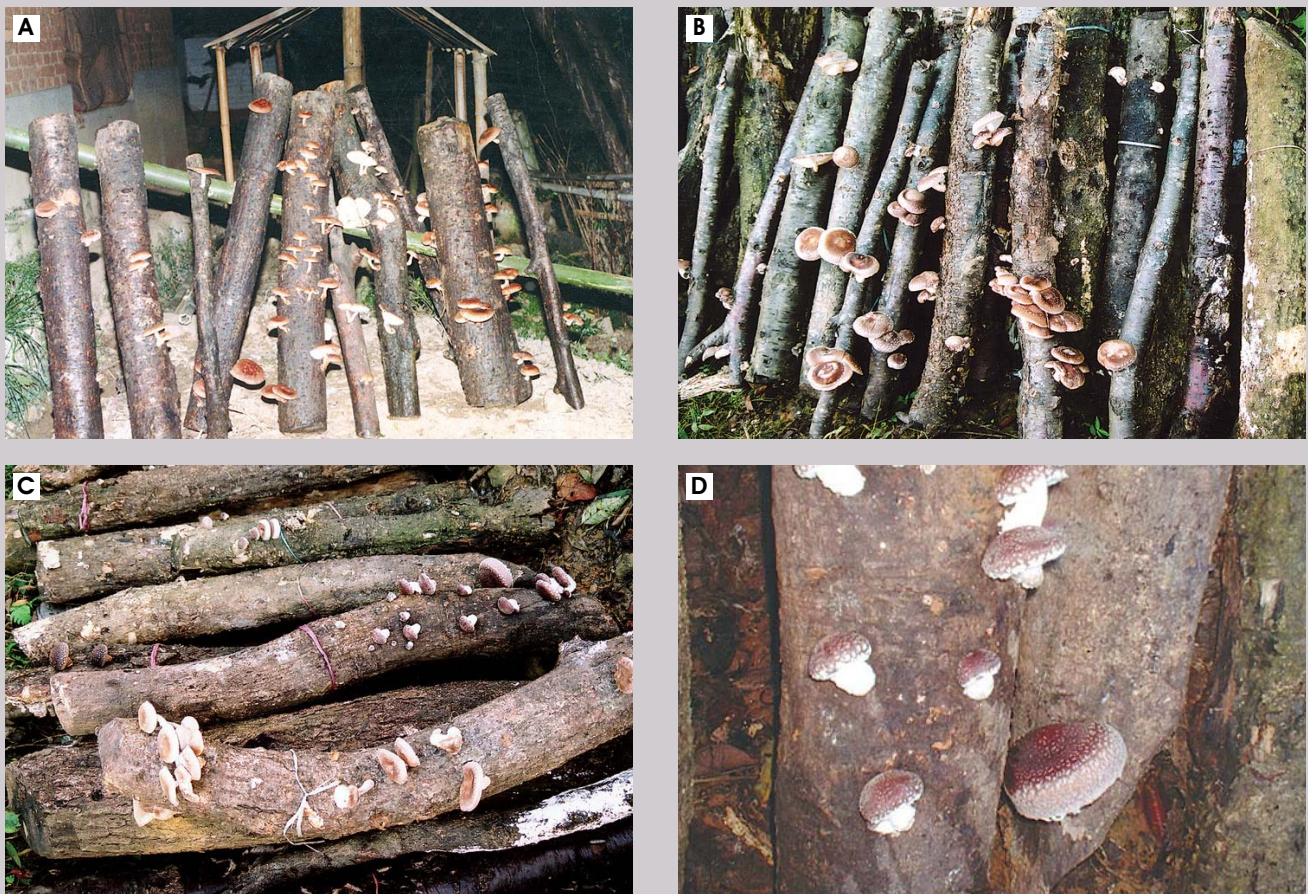


**Figure 3.** Tree felling and inoculation **A:** Cutting the tree logs by axe **B:** Drilling the wood logs to make the holes **C:** Spawning the logs with hand **D:** Waxing the inoculated holes with molten wax

These inoculated logs are piled and sprinkled with water 2-3 times a week and stored for a month (Figs 4A, B and C). Then the logs are turned upside down and stacked again. The same process is repeated every month and the wood log stacking is done in the same way throughout the spawn run period. Some farmers piled the logs in a crib stack and watered them every 4-5 days.



**Figure 4.** Incubation and fruiting induction **A:** Wood logs stacked inside a plastic bamboo shed-Chhampy **B:** Wood logs stacked in shed - Kakani **C:** Sprinkling water on logs **D:** Water tank (small pond) for dipping logs in water



**Figure 5.** Fruiting **A:** Shiitake from *Alnus nepalensis* **B:** Shiitake on *Betula alnoider* **C:** Shiitake on *Castanopsis* **D:** Small caps on *Castanopsis*

Eight month after inoculation, logs would be ready for fruiting. To check if the logs are ready for induction, growers split on to view the mycelial growth. In September when the average temperature is 24-26°C and humidity 80-90%, the logs are dipped in water in a small pond or a metallic container for a period of 24-48 hours for induction (Fig. 4D). After dipping, the logs are arranged in a row on the bamboo stand at a distance of 4-6cm. Watering is done every day so as to keep the logs moist. A week after fruiting induction the young fruiting bodies start to appear on some logs. Shiitake can be harvested from October to December. The production slows in January and starts to up again from February through May. The production of shiitake usually stops in summer due to hot weather. Shiitake is harvested for three years in all the tree species. In tests *Castanopsis* logs produced larger harvest than the other two species, but the exact yields have still to be estimated, and this work continues.

Farmers have adopted the described process and some of them have succeeded. Logs of *Alnus*, *Betula* and *Castanopsis* trees were recommended in the area near a forest, where cool and humid conditions prevail in the seasons mentioned above.

### Spawn Supply and Shiitake Marketing

At present CAT is the only shiitake spawn supplier and it is using sawdust from *Alnus* trees to prepare the spawn. Spawn is packaged in polypropylene bags using pure cultures of shiitake strains. The promotion of shiitake cultivation was initiated by CAT in 2002. To date about 25 farmers have started to inoculate wood logs. Some farmers have already produced shiitake and others have crops still in the spawn run stage.

CAT has collected all the shiitake produced by the farmers around Kathmandu and has itself sold this crop. The clients have been mostly



**Figure 6.** Shiitake in plastic packets for sale

Japanese, American, European and other foreigners staying in Nepal. There have been some Nepalese consumers but the cost of shiitake in the market is too high for most Nepalese. There is a special market for organic vegetables in Hotel Summitt on Sundays and Wednesdays. Shiitake are often sold in this market. In addition, attempts have been made to sell shiitake in local department stores that cater to Nepalese consumers but the mushrooms are not yet popular for these customers. The price for 1kg of fresh shiitake is NPR500 (USD6.94), which is too costly for an average Nepalese family. For the time being the domestic shiitake market is limited, so neighboring countries with bigger shiitake markets can act as the target markets until the domestic Nepalese market develops more fully.

## Case Studies

Though experience is minimal, some successful cases in the early stages are provided here. Productivity varies widely according to individual farmers. Some farmers produce two or three times more than others.

A farmer named Ramu Raut has cultivated shiitake on *Alnus* logs since 2002. He has used wood logs of various diameters, from 5 to 20cm, he has not sprayed enough water on the logs, and the local environment is not quite ideal for mushroom cultivation. His costs and income from shiitake growing are as follows. This farmer is expected to harvest for one more year, so the accumulated volume of production will increase.

A farmer named Sher Bahadur has cultivated shiitake on *Alnus* wood logs since 2003. He has started only 40 logs, so his costs have been low. He received NPR500/kg at the market for his harvested shiitake. He harvested 12kg of shiitake in 2003 and 22kg in 2004. He is still having good harvest and 10kg is expected in 2005. Totally, he is expected to harvest 44kg from 40 logs and earn NPR20,000 (USD277.59) for 3 years. Therefore, the yearly net profit is NPR6,000 (USD83.28) from shiitake growing, an additional income source.

**Table 3.** Cost for shiitake log cultivation of Ramu Raut

Items	Unit cost in NPR	Cost in NPR
7 trees (70 logs)	300 / tree	2,100
Labor		600
Spawn	30 / bottle	500
<b>Total cost</b>		<b>3,200</b> (USD44.41)

**Table 4.** Yield and income from shiitake production of Ramu Raut

Year	Volume of production (kg)	price per kg in NPR	Income in NPR
2002	6	500	3,000
2003	5.5	500	2,750
2004	3.5	500	1,750
<b>Total production</b>	<b>15</b>	<b>500</b>	<b>7,500</b> (USD104.09)

**Table 5.** Cost for shiitake log cultivation of Sher Bahadur

Items	Unit cost in NPR	Cost in NPR
4 trees (40 logs)	300 / tree	1,200
Labor		500
Spawn	30 / bottle	300
<b>Total cost</b>		<b>2,000</b> (USD27.76)

**Table 6.** Yield and income from shiitake production of Sher Bahadur

Year	Volume of production(kg)	price per kg in NPR	Income in NPR
2003	12	500	6,000
2004	22	500	9,000
2005	10 (expected)	500	5,000
<b>Total production</b>	<b>44</b>	<b>500</b>	<b>20,000</b> (USD277.59)



**Figure 7.** Training on shiitake given to farmers

Shiitake farmers in Nepal have learned that shiitake cultivation requires cool and humid climatic conditions near forests and that their productivity depends on proper care and watering. One notable production aspect that needs to be improved is maintaining an appropriate moisture in the logs. Farmers in Nepal feel that they are just starting to understand the cultivation requirements of shiitake. While it cannot be said at present that shiitake growing is more profitable than growing other mushrooms in Nepal, this new product will surely attract new consumers as well as farmers.

## Part I Shiitake

## Chapter 4

Shiitake Bag Cultivation**SHIITAKE BAG CULTIVATION**

Alice W. Chen

Specialty Mushrooms, 1730 Penfield Rd. #41, Penfield, NY 14526, The U.S. (alicewchen@msn.com)

Shiitake (*Lentinula edodes*), a mushroom of culinary delight and medicinal benefits, was traditionally cultivated on natural logs. Although shiitake spontaneous-log cultivation was discovered in China, Japanese farmers have been instrumental in developing shiitake cultivation on natural logs as a science and an industry. For nearly half a century, from 1940's until 1986, Japan was the leading producer of shiitake worldwide. As late as 1983, Japan accounted for 82.8% of the entire shiitake world production. A dramatic change in the global dynamics of shiitake production occurred in 1987. China overtook Japan, for the first time, as the number one shiitake producer in the global market by producing 178,800 tons. What most contributed to the quantum-leap in shiitake production in China was the invention of bag cultivation using sawdust as a growing substrate. In particular, the success came through the use of cylindrical sawdust bags in Gutian, Fujian. The Gutian model was quickly replicated in many parts of China with local adaptations (Fig. 1A). The well-known Biyang model today is one particular version of this system (Fig. 1B). As Daniel Royse (2002), the current leading authority on shiitake sawdust bag cultivation at Penn State University in the U.S. ([www.psu.edu](http://www.psu.edu)) pointed out; the trend of worldwide shiitake production is leaning towards sawdust bag cultivation. Bag cultivation technology makes it possible to produce shiitake all year around to meet market demands.



**Figure 1.** Cylindrical sawdust bags for shiitake growing **A:** Gutian model **B:** Biyang model

### Types of Shiitake Cultivation Processes

Table 1 shows the cultivation processes commonly used by shiitake growers. Descriptions of other modifications can be found in Chang and Miles (2004), Chen, Arnold and Stamets (2000), and Oei (2003).

**Table 1.** Commonly used shiitake cultivation processes

	Spawning	Spawn run	Fruiting	Bag	Growing cycle
<b>Log cultivation</b>	Localized	In nature (under shelter)	In nature (under shelter)	No bag	Slow
<b>Bag cultivation</b>					
<b>A. Cylindrical</b> developed in China / the substrate is usually compressed	Localized	Indoor (little environmental control)	Outdoors	Cotton or foam plugs (no air space in bag)	Moderate
<b>B. Sawdust blocks</b> 5-6 kg per bag / developed in the U.S. - brown in bag - brown out of bag	Through	Indoor (control)	Indoor (control)	Micro-filter breathing window / air space in bag / bags sealed	Fastest
<b>C. Sawdust slates</b> 15 kg per bag / developed in Europe	Localized (eg. liquid spawn injection)	Indoor	Indoor	No air space in bag / both micro-filter and foam plug are used	Fast



**Figure 2.** Types of shiitake cultivation **A:** Natural-log cultivation (the U.S.) **B:** Cylindrical sawdust synthetic logs (Tibet, China) **C:** Sawdust-block cultivation (Fungi Perfecti, the U.S.) **D:** Sawdust-slate cultivation (Europe)

## Preparation of Shiitake Sawdust-bag Cultivation

### Strain selection

Shiitake strains are temperature-dependent. Strains are classified according to their preferred temperature during the fruiting period (Table 2). The growth rate during spawn run also differs according to the different strains, and results in either

short or long durations for the mycelial maturation. Some short-duration strains take only 60 days to mature while long-duration strains require 90 days. Malformation of mushrooms may occur as a consequence of farmers attempting to force fruiting too early.

**Table 2.** Shiitake strains classified according to fruiting temperature (°C)

Strain	China (Wu (ed), 2000)	General (Oei, 2003)	Taiwan (Chang and Miles, 2004)
Low temperature strains	< 10	around 10	-
Medium temperature strains	10-20	10-18	10
High temperature strains	> 20	20 or > 20	20
Wide-range temperature strains	5-35 (for example, China-Stamets 2)		

It is important that a strain is selected that matches a grower's specific needs. Shiitake strains vary widely not only in fruiting temperature, maturation characteristics (early or late; shorter or longer production time), but also in substrate selectivity, growth rate, fruiting quality (size, thickness, color and fragrance, etc.), yield and ecological adaptability to extreme temperature. The strains used for natural log cultivation are different from the strains that are used for sawdust bag cultivation. In sawdust bag cultivation, the strains used for the brown-in bag procedure and the strains used for the brown out of bag procedure are different. Unfortunately, some serious losses in yield have occurred because spawn makers have sold new strains that produce well on natural logs but produce very low yields when cultivated on sawdust. Some strains perform better on a substrate of corn cob while others perform better on a sawdust substrate (Oei, 2003).

### Substrate selection

Selection of the tree species for sawdust cultivation should be done carefully. Fresh sawdust that has not been aged can be used for production of shiitake only if it is from high quality tree species, such as those graded 4, excellent, by the FAO (Oei, 1996). Oak (*Quercus* spp.), chinkapin (*Castanopsis* spp.), hornbeam (*Carpinus* spp.), sweetgum (*Liquidambar* spp.), poplar (*Populus* spp.), alder (*Alnus* spp.), ironwood (*Ostrya virginiana*), beech (*Fagus* spp.), birch (*Betula* spp.), and willow (*Salix* spp.) are examples of commonly used non-aromatic broadleaf hardwoods. Sawdust from tree species of lower quality has to be

aged before it can be used successfully (Oei, 1996; Royse, 1997; Ting, 1998; Wu *et al.*, 1995). Farmers should of course select locally available and inexpensive resources and use it accordingly. As an example, fermented *Eucalyptus* sawdust has been used successfully for shiitake production in Australia by Dr. Noel Arnold.

**Table 3.** Formulation of sawdust-based substrates for shiitake cultivation

<b>Formulation A</b> (Wu, 1993)	hardwood sawdust	100kg
	wheat or rice bran	23-25kg
	gypsum	2.5kg
	calcium superphosphate	0.5kg
	sucrose	1-1.5kg
	water	100-140kg
<b>Formulation B</b> (Stamets, 1993, p.162)	hardwood sawdust	100lb (or 64gal)
	wood chips	50lb (or 32gal)
	rice or rye bran	40lb (or 8gal)
	gypsum (calcium sulfate)	5-7lb (or 1gal)
	water	60%
<b>Formulation C</b> (The Forestry Research Institute of New Zealand)	Monterey pine sawdust ( <i>Pinus radiata</i> )	6 part
	hardwood sawdust (beech or poplar)	3 part
	grain (barley)	1 part

### Substrate formulation

Table 3 shows examples of commonly used sawdust-based substrate formulations. Non-aromatic hardwoods are usually used. In addition to hardwood, utilization of pine is a subject of great interest, since pine is a readily available forestry resource. Supplemented pine-hardwood substrate (Table 3. formula C) was used successfully by the Forestry Research Institute of New Zealand to produce shiitake with satisfactory results (Stamets, 1993). Agricultural wastes, such as cottonseed hulls, corn cobs, bagasse, straw, coffee residue can also be used as alternative basal ingredients<sup>1</sup>. The C/N ratio of the substrate must be around 25 at spawning (inoculation). For substrate formulations, growers can read Miles and Chang (1989) and Oei (1996, pp.198, 200) and Chapter 4 of this book (2005). A high water-holding capacity of the substrate combined with good aeration usually gives good results. If the substrate is too wet, the air flow in the substrate will be clogged. If the water collects at the bottom of the bag, the substrate is too wet.

<sup>1</sup> For more details, see ALTERNATIVE SUBSTRATE OF SHIITAKE in chapter 4.

### Substrate sterilization

The method used for substrate sterilization depends on the nature of bags (polypropylene or polyethylene<sup>2</sup>), bag size, and, the nature and amount of the substrate. For 2-3kg sawdust-based substrate in polypropylene bags, sterilization can be done in autoclave for 2 hours at 121 °C. Normal pressure sterilization is also possible, and this method is commonly employed in Thailand and China. Thai farmers generally utilize drums for sterilization and Chinese farmers use kilns<sup>3</sup>.

## Shiitake Production on Sawdust Bag Cultivation

### Spawning



Figure 3. Various bags A: Partly filled bags B: A fully filled bag

In general, top or localized spawning, in which spawn is left on or near the surface of the substrate, is used in China, Asia, and Australia. Through spawning in which the spawn is thoroughly mixed with the entire substrate, in heat-sealed bags is used in the U.S. Larger bags with micro-porous breathing filters, partly filled with the substrates, allow the manipulation of mixing the spawn thoroughly with the substrate by mechanical shaking or manual manipulation (Fig. 3A). Smaller bags with ring necks and plugs such as those used in Asia and Australia are filled full with substrate and no air space is left in the bag. These smaller bags do not lend themselves easily to procedures for through spawning (Fig. 3B).

Caution should be taken to avoid mold contamination during spawning. Not more than 5% of the bags should be contaminated. If the contaminated molds are near the top of the bag, it is likely that the contamination gained entry during inoculation. If the contamination occurs on the bottom or side, farmers should check the bottom of the bag to see if it is sealed properly or if the

side of the bag has been punctured. If the mold is scattered throughout of the substrate, the substrate sterilization duration might have been insufficient, or the spawn used might have been contaminated (Oei, 2003). A new grower may be tempted into a money-saving scheme and may buy only a small amount of grain spawn. When he inoculates the purchased spawn into some grain he has sterilized himself to multiply the amount, unfortunately the whole lot is often contaminated, and his money saving scheme actually wastes money.

### Spawn run (mycelial growth and maturation)

All shiitake strains show optimal mycelial growth during the spawn run at 25 °C. The duration of the spawn run is usually 1-4 months. Although mycelia can grow in darkness, light exposure in the first three weeks of spawn run is critical for the browning of the mycelial blocks. Some light in day/night cycles towards the end of the spawn run is conducive to the induction of primordia. It can be difficult to judge the timing for lighting during spawn run. Different approaches can be used, such as short exposure to light, e. g. 4 hours per day (Royse, 1997) or a low level of light, 50-100 lux throughout spawn run (Stamets, 1993). When the shiitake substrate is fully colonized by the white mycelia, this does not mean that the block is ready for fruiting. A mycelial maturation stage is also required. Shiitake has a complex vegetative mycelial stage composed of six stages.

- 1) **Colonization of mycelia in the substrate:** Enzymes are produced to degrade components in the complex substrate such as cellulose, hemicellulose and lignin.
- 2) **Mycelia mature physiologically:** Mycelia stop growing, while physiological metabolic changes occur.
- 3) **Mycelial coat formation:** Thick, white mycelial coat is formed on the substrate surface, 2-4 weeks after inoculation (spawning) in most strains (Fig. 4B). Very thick coat is formed at high CO<sub>2</sub> levels.
- 4) **The popcorn stage:** Clumps of mycelia are developed in some strains giving a bumpy or pop-corn like surface (Fig. 4C). Primordia are produced at the tips of some bumps (Fig. 4D). However, most bumps are aborted. Fluctuation of temperature and high CO<sub>2</sub> level encourages bump formation. Over-developed bumps may puncture the bag. Bumps can also be susceptible to contamination by weed molds. Some aeration should be provided when bumps are formed.
- 5) **Browning:** Two different cultivation practices are used in the American system: brown-out-of-the-bag or brown-in-bag (Fig. 4E); bags are stripped before pigmentation in brown-out-of-the-bag (Royse, 1997), or bags are stripped after browning

<sup>2</sup> Polypropylene is heat-resistant, so suitable for high pressure sterilization. Polyethylene is divided into high pressure type and low pressure type.

<sup>3</sup> For more details, see SHIITAKE BAG CULTIVATION IN THAILAND and SHIITAKE BAG CULTIVATION IN CHINA in chapter 4.

(brown-in-bag). Some growers remove the bag when 1/2 to 1/3 of the mycelia have become brown. The timing of bag removal is crucial, and yield can be affected if bag removal is too early or too late.

- 6) **Bark-forming:** In the open air, mycelia turn reddish brown at the surface and eventually forms a dark brown and dry outer protective surface which functions like a tree bark. The inner substrate becomes soft and moist as a consequence of fungal metabolic activities. Growers should be aware that a moist coat invites contamination, and should maintain 60-70% R.H. to avoid contamination.



**Figure 4.** Spawn run process **A:** Bags under spawn run (Garden City Fungi) **B:** Fully colonized shiitake blocks (Client of Unicorn bag) **C:** Pop-corn like surface (Fungi Perfecti) **D:** Primordia formed at the tips of bumps (Fungi Perfecti) **E:** Brown in bag (Garden City Fungi) **F:** Mycelial running the popcorn stage, and browning (Garden City Fungi)

Growers should keep in mind that in shiitake cultivation, a chosen shiitake strain may prefer a certain substrate and may require a particular cultivation practice and a specific set of environmental factors for successful production. Providing an optimal environment for cultivation is vital after the best shiitake strain and substrate are chosen. Regardless of the fruiting

temperature of the strain, approximately 25 °C is the temperature for spawn run for all strains. Each developmental stage (spawn run, primordia initiation, fruiting) in shiitake cultivation requires a specific set of growth parameters (temperature, relative humidity, light and oxygen supply).

In the American system of heat-sealed bags with micro-filter breathing window gas exchange takes place through micro-porous filters. Such filters prevent rapid loss of water vapor and dehydration, thus keeping the substrate in the bags moistened. The humidity inside of the sealed bags remains high (95-100% R. H.). The design of the special micro-porous filter on the bags makes it practically care-free to manage the incubation of the spawn. It is not necessary to lower the level of accumulated CO<sub>2</sub> because the vegetative mycelia is tolerant of high concentrations of CO<sub>2</sub> up to >10,000 ppm. Ambient humidity is not critical during this period, since the bags are sealed. Growers are simply leave the inoculated substrate in the sealed bags at the natural humidity, which can be as low as 40-50% R. H.. Some growers use the same light for spawn run and fruiting, but during incubation they stack the bags next to each other to cut down the levels of available light reaching the bags (case study 1). Other growers maintain a low level of light (50-100 lux) throughout incubation (case study 2). A constant temperature of approximately 25 °C is kept for all strains during the vegetative phase, although as in nature, a variable temperature also works well sometimes.

### Fruiting induction for primordia initiation (Oei, 1997)

Regardless of the specific techniques used, at least some change of the environment is necessary for the transition from vegetative phase to reproductive phase (Table 4 and 5).

When the shiitake mycelia are fully matured, fruiting is induced. The following actions promote fruiting:

- temperature fluctuation
- high humidity
- water soaking (Royse, 1997: 2-4 hours at 12 °C; Stamets, 1993: 24-48 hours)
- removal of CO<sub>2</sub>; supply fresh air through ventilation
- physical shocks (agitation, disturbance):
  - stab (with a long metal needle) and inject (with water)
  - turn the blocks up-side down
  - beating (natural logs)

**Table 4.** The concept of environmental change in triggering primordia formation in fruiting for shiitake cultivation

To initiate primordia in fruiting:	
Decrease in	1) temperature 2) CO <sub>2</sub> concentration
Increase in	1) light intensity 2) humidity: ambient humidity in the fruiting room 3) O <sub>2</sub> supply: through increase of fresh air flow and decrease of CO <sub>2</sub> levels by ventilation

Note: See specifics on growth-parameter management in case studies.

**Table 5.** How to trigger fruiting, by changing environmental growth parameters

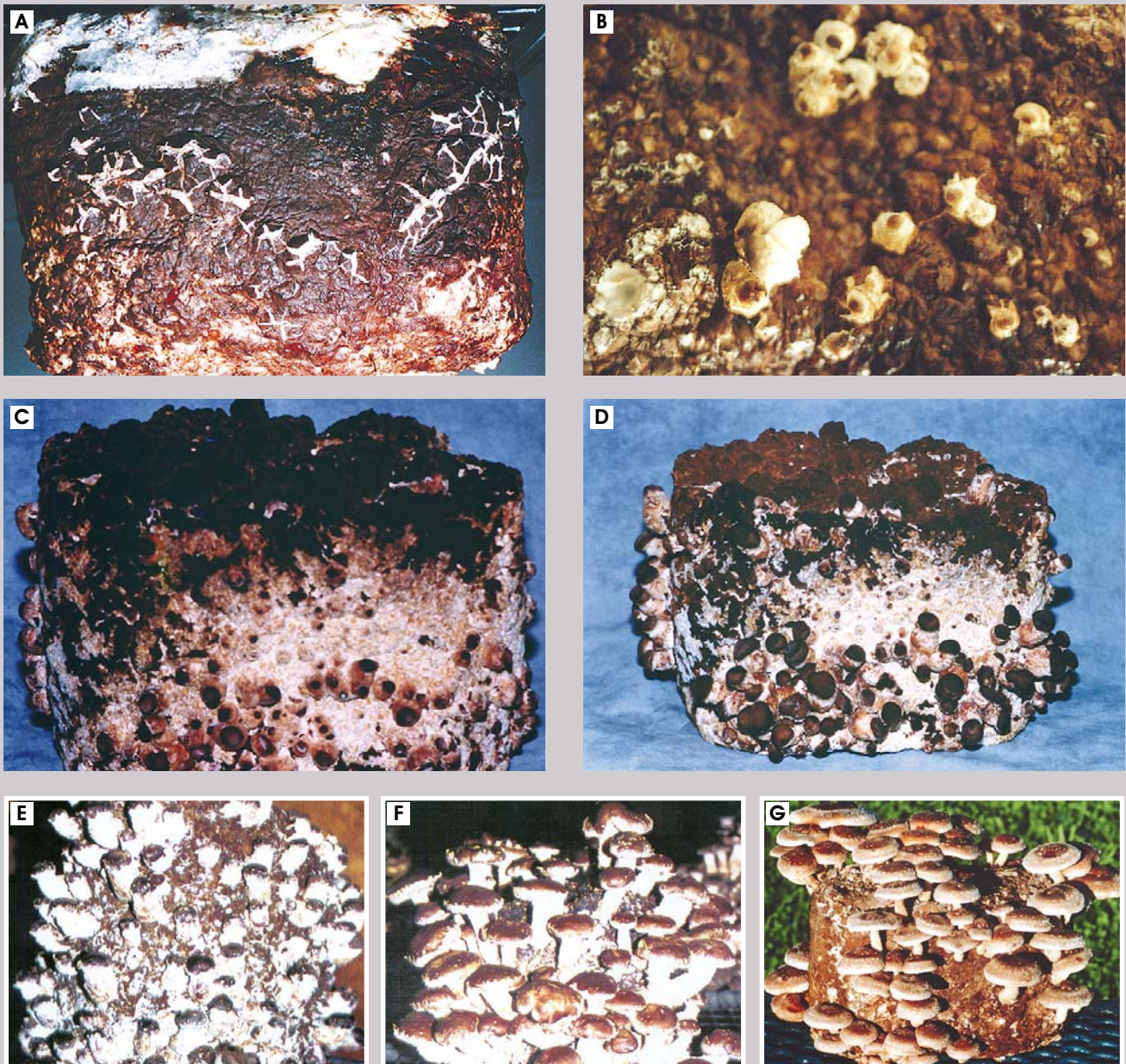
1) Lower the temperature (according to the strain, see case studies)
2) Lower the CO <sub>2</sub> level, to CO <sub>2</sub> < 1,000 ppm, while
3) Increase O <sub>2</sub> supply by raising the frequency to 4-8 air exchange per hour
4) Increase the ambient humidity, such as to 60-80% R. H. depending on the strain and the type of cultivation practice
5) Increase light intensity, such as to 500-2,000 lux at 370-420 nm

### Fruiting development

The illustrated guide below lists developmental stages in shiitake fruiting body formation in shiitake sawdust bag cultivation.

- primordia formation at the tip of the bump (blister) in the pop-corn stage (Fig. 4C)
- formation of young dark mushroom buttons (Figs. 5B, C and D)
- elongation of the stipes (stalk) as the buttons increase in size and becomes lighter in color (Figs. 5E and F)
- mushroom caps gradually unfold from in-rolled downward, while basidiospores develop in the fertile gills under the mushroom cap

Detail description of developmental stages in shiitake fruiting can be found from further reading (Chang and Miles, 2004; Chen, 2001, 2004). During fruiting, fluctuating light is generally used. Some growers keep the temperature and humidity constant, while others simulate nature by fluctuating both the humidity and temperature, and this practice produces crops of higher quality. At the grower Fungi Perfecti, the constant and at times drastic fluctuation of humidity, during fruiting, not only improves mushroom quality but also discourages mold contamination. Several times a day, the humidity is allowed to fluctuate between 70-90% R.H.. Shiitake caps formed under such conditions have a tougher leathery outer skin which sustain a much longer shelf life (Stamets, 2000).



**Figure 5.** Fruiting development (Fungi Perfecti and others) **A:** Star-like cracks formed after water soaking **B:** Very young mushroom caps are formed **C:** Small young fruiting bodies **D:** Caps become larger, stems longer **E** and **F:** Development of fruiting bodies **G:** Lighter matured fruiting bodies

### Harvest and subsequent flushes

To encourage better mushroom shelf life, the humidity should be lowered to 60% R.H. for 12 hours before harvesting shiitake. The desirable harvest stage for brown-in-bag technique occurs when the edge of the shiitake caps are still in-rolled downward

(60-80% cap expansion). Shiitake are hand picked by holding the mushroom stalks and gently twisting away from the substrate blocks. To prepare shiitake for the markets, growers cut off residual stubs of stalks from the substrate and trim the ends if necessary. Remnants of residual substrate are vulnerable to mold contamination.

After harvest, the humidity is lowered to 30-50% R.H. at 21 °C for 7-10 days to induce dormancy (Stamets, 2000). The substrate blocks are then soaked for up to 12 hours to induce the second flush of the mushrooms, and up to 18 hours for the third flush (Royse, 2001). Larger bags of more substrate (5-6lb wet substrate) produce more, up to 5-6 flushes of mushrooms. Harvested mushrooms not sold as fresh shiitake are dried at 60 °C.

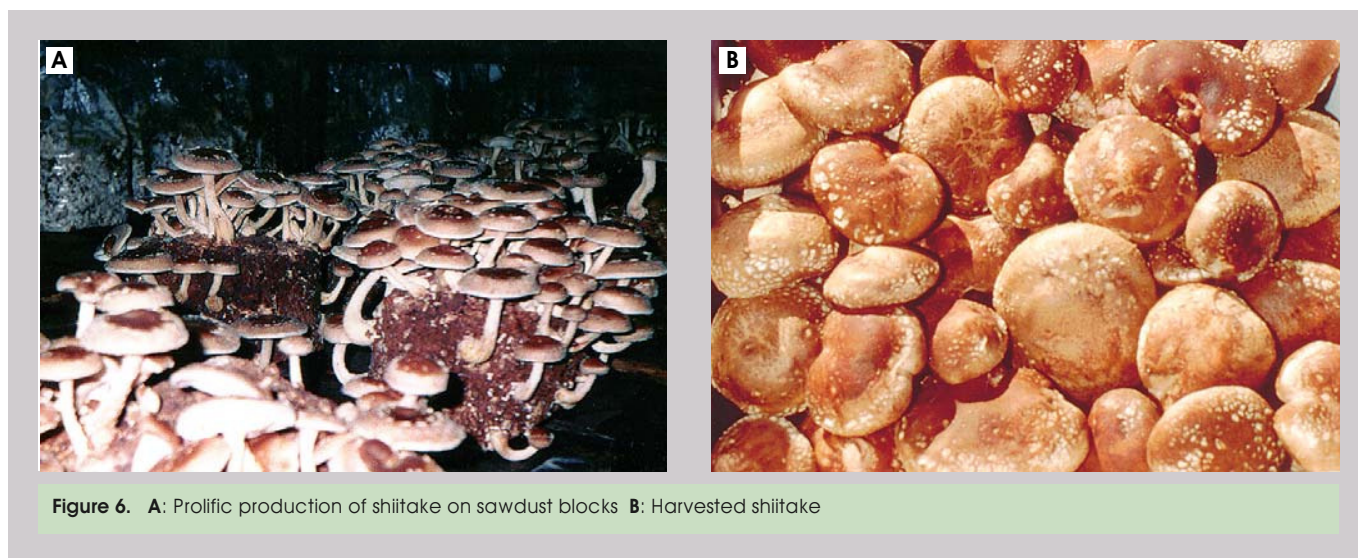


Figure 6. A: Prolific production of shiitake on sawdust blocks B: Harvested shiitake

### An Overview on Sawdust-block Cultivation in the U.S.

A review of shiitake sawdust-block cultivation by Hsu, 2003 (Table 6) shows that the 250 or so serious exotic mushroom growers in the U.S. generally use two cultivation practices in growing shiitake; brown-in-bag and brown-out-of-bag. During the spawn run in the vegetative phase, the first method keeps the sawdust blocks in the bags until a brown skin (or bark) is formed before stripping the bags. In the second method, the bags are stripped much earlier when the matured mycelial blocks are still white. Curing of the stripped blocks for browning outside of the bag is done in a curing room for about 30 days. This is followed by soaking (immersion) the blocks in cold water to trigger primordia formation, the initial stage of fruiting. Fruiting bodies are formed 3-4 days later in the fruiting room. For browning in the bags, primordia formation can be initiated by spraying water or by other means such as the use of fluctuating temperatures.

The brown-in-bag procedure usually produces meatier, darker, thicker mushroom caps. The down side of this method is a longer growing cycle, so more shelf space is required. In the brown-out-of-bag system, the crop has a shorter growing cycle. Mushroom will grow faster on highly supplemented substrates that are sometimes composed of more than 45% nutrients. The produced shiitake have thinner caps and a lighter color, and special strains developed in China are used for this type of a cultivation. The different growth parameters for these two methods are shown in Table 7.

Choosing a process is a decision that depends on what kind of shiitake mushrooms consumers want in the targeted markets. A grower's skill in managing the cultivation process is another important consideration. If the grower is able to recognize physiological maturity of the white mycelial blocks, browning out of the bag is the best practice. In contrast, the maturation of the substrate in the browning-in-bag system is visually apparent, but the growing cycle is longer. Space, temperament of the grower, and hygiene management skill should all be considered. If the market already has quality shiitake that consumers are familiar with, it could be a challenge to introduce a new product. It usually takes special marketing talent and persistent effort to nurture consumers' interest for new products.

**Table 6.** An overview on shiitake sawdust-block cultivation in the US, brown-in-bag vs. brown-out-of-bag (Hsu, Lou, 2003, Unicorn, TX, the U.S. with author's notes\*) www.unicornbags.com

	Brown-in-bag	Brown-out-of-bag
<b>Color of the block at stripping *</b>	Take the block out when brown	Take the block out when white
<b>Bag used</b>	Unicorn type 3T 14	Unicorn type 14
<b>Block weight</b>	5-6lb	5-6lb
<b>Substrate mix</b>	75-80% sawdust / 20-25% supplements	55-65% sawdust / 35-45% supplements (occasionally > 45% supplements)
<b>Type of sawdust</b>	Oak preferred	Oak preferred
<b>Sawdust size (typical)</b>	30-60 mesh, 70%	30-60 mesh, 70%
<b>Sawdust chips (typical)</b>	5-10mm, 30%	5-10mm, 30%
<b>Nutrients (wheat bran, rice bran, corn waste, millet, or other grain)</b>	Locally available	Locally available
<b>Gypsum &amp; Calcium sulphate</b>	0.5-2 %	0.5-2 %
<b>Environmental growth parameters</b>	See table 7.	
<b>Feature of outer brown bark</b>	Adequately formed	Well-formed, high quality
<b>Primordia initiation</b>	Water spraying, etc.* (water soaking, fluctuation of temp.)	Water soaking by immersion
<b>Type of strain</b>	Low temperature	Fast growing (Usually of higher fruiting temp. special strains from China)
<b>Fruiting</b>		Mushrooms formed 3-4 days after soaking in cold water
<b>Type of mushroom</b>	Large cap, meaty	Thinner cap
<b>Mushroom diameter</b>	3 inch	2-3 inch
<b>Number of flushes</b>	2-3 to 4-5*	2-3 to 4-, depending on block conditions, brown bark, etc.*
<b>Average weight of 1<sup>st</sup> flush</b>	4-8%	8-17%
<b>Average weight of 2<sup>nd</sup> flush</b>	4-8%	4-8%

## Environmental Management during Sawdust-block Cultivation in the U.S.

**Table 7.** Environmental control of shiitake production on sawdust blocks in the U.S.; brown-in-bag vs. brown-out-of-bag (Hsu, Lou, 2003.) www.unicornbags.com

	Brown-in-bag	Brown-out-of-bag
<b>Spawn run temperature</b>	20 °C: 1 month 18 °C: 1 month	20 °C: 15-25 days Strip bag
<b>Browning temperature</b>	During incubation in bag	18 °C: 30 days
<b>Primordia initiation</b>	Strip bag, water spray, water soaking, fluctuation of temp.etc.	Soak by immersion in cold water
<b>CO<sub>2</sub> (during spawn run)</b>	*no restriction before bag stripping	*no restriction before bag stripping / 8,000 ppm at curing
<b>CO<sub>2</sub> (during fruiting)</b>	1,000 ppm and less	1,000 ppm and less
<b>Lighting (during spawn run)</b>	50-100 lux before bag stripping	50-100 lux
<b>Lighting (during fruiting)</b>	500-1,000 lux after bag stripping	500-1,000 lux

\* Notes by author: Low CO<sub>2</sub> level is not necessary during mycelial stage. See case study and text. No need to regulate CO<sub>2</sub> concentration, nor to maintain high humidity during spawn run. Easy management.

## Case Study 1

Garden City Fungi, a successful grower in cultivating shiitake and other exotic mushrooms in the U.S. provided the following practical information on growing shiitake in sawdust blocks by browning in the bag (Glen Babcock, 2004).

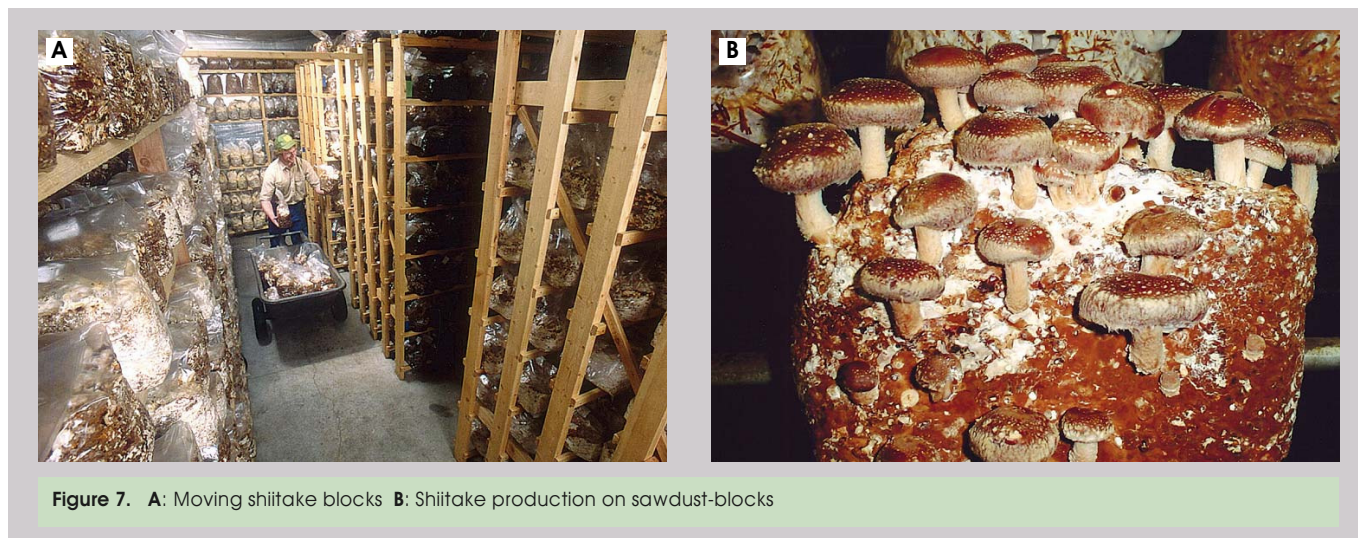


Figure 7. A: Moving shiitake blocks B: Shiitake production on sawdust-blocks

**Table 8.** Selection of shiitake strains and preparation of substrate blocks by Garden City Fungi, Montana, the U.S. ([www.gardencityfungi.com](http://www.gardencityfungi.com))

<b>Shiitake strains</b>	Duration, 60-90 days, Garden City Fungi strains 60 days: GCF 1011 90 days: GCF 1007 Both work well, produce dark mushrooms with nice flecking on the cap
<b>Substrate block weight</b>	6lb (wet weight)
<b>Bag type</b>	Unicorn #14
<b>Substrate moisture content</b>	65%
<b>Micro-porous filter</b>	1 per bag
<b>Air space in bag</b>	100 cubic inches $\pm$ = $\frac{1}{2}$ of the bag
<b>Substrate formulation</b>	Hardwood sawdust ( <i>Alder</i> or oak) 48% Recycle sawdust (spent substrate) 32% Millet supplement 10% Bran supplement (wheat bran) 10%
<b>Grain spawn</b>	$\frac{1}{2}$ cup rye-grain spawn per 6lb substrate block through spawning
<b>Autoclave sterilization</b>	Bulk of 400 blocks for 6.5 hours, at 121 °C

**Table 9.** Environmental control of growth parameters in shiitake sawdust–block cultivation, browning in bag (Glen Babcock, Garden City Fungi, 2004. [www.gardencityfungi.com](http://www.gardencityfungi.com))

	Spawn run	Browning	Primordia initiation	Fruiting
<b>Temperature</b>	18-20 °C; constant throughout day and night	During spawn run in bag / Additional browning 4-5 days out of bag when necessary	By temp. fluctuation after stripping the bag / Lower temp. into 12 °C at night	Daily fluctuation between 13-20 °C (8 hours at 13 °C/8 hours at 15-18 °C/ 8 hours at 20 °C)
<b>Light (fluorescent light)</b>	10-12 hours per day same light source blocks (closely stack-ed) receiving less light	Same as spawn run	10-12 hours per day	10-12 hours per day / 1,800-2,000 lux by estimate blocks (spaced further apart) receiving more light
<b>Humidity (R.H.)</b>	Not important as bag is sealed / 40-50% R.H. in building	Same as spawn run	High humidity generated by humidifier	85-95% all the time
<b>Oxygen supply</b>	Air exchange 0-1 / hour	Air exchange 5/hour		Air exchange 5/hour
<b>CO<sub>2</sub> level</b>	No limit	No limit	< 1,500 ppm	< 1,500 ppm
<b>Duration</b>	60-90 days Strain-dependent over 2 month		4-5 days from bag stripping to formation of very young primordia	2-3 flushes 6-10 days from primordia to formation of mature mushrooms
<b>Yield</b>				2-3lb per block on average

### Notes from Garden City Fungi:

**Light source:** 3,000 lux or so per light, 1 bulb for every 20 ft<sup>2</sup> of incubation space. Distance of light source to block space, approximately 3-4 ft range of light. It is estimated that such lighting set-up gives 1,800-2,000 lux light intensity received by substrate blocks.

**Oxygen:** There is a continual flow of fresh air (frequency for air exchange 5/hour) during primordia initiation and fruiting.

**Browning:** Strip the bag when browning throughout of the bag. In practice, a batch of 400 blocks are inoculated at a time at Garden City Fungi. When the time comes to open the bags, even if not all the blocks are brown throughout, all the bags are stripped. Timing is determined by blocks reach 70% or more in browning inside of the bags by prior experience. Such practice in timing is based on the fact that space is needed to start new blocks. Substrate blocks will produce mushrooms even if they are not entirely brown at stripping, as long as browning reaches 70% or more in each block. By the time blocks are done fruiting, the blocks which were not completely brown at bag stripping, will have complete browning. It takes about 2 weeks from bag stripping to finish harvest.

**Primordia initiation:** Allow the building to cool down to 50°F at night, then warm up during the day. This simulates real conditions in nature where mushrooms grow in the wild. The strains used by Garden City Fungi do not form primordia well if they are not subjected to the stimulation of cool temperature in diurnal fluctuation.

**Humidity:** Humidity fluctuates as the temperature rises and falls. When the heater turns on in the morning, it will warm the air. As the temperature rises at this time, the humidity will fall to about 85% R.H. Once the temperature is stabilized, the humidity will return to 95%. Once again, it simulates natural conditions.

**Markets for Garden City Fungi in the U.S. :** Inland northwest 70% / Midwest 20% / California and other southern states 10%

## Case Study 2

Fungi Perfecti ([www.fungi.com](http://www.fungi.com)), Olympia, Washington State, the U.S. (Paul Stamets, 2000), renowned worldwide. Usually brown in bag.

Humidity is high in the sealed bag during spawn run. During fruiting, fluctuate humidity several times a day (70-90% R.H.). Shiitake require lower humidity during fruiting body formation compared to some other mushrooms. Lower the humidity to 60% R.H. prior to harvest for 6-12 hours to improve shelf life.

**Table 10.** Shiitake sawdust-block cultivation at Fungi Perfecti, growth parameters

	Spawn run (usually brown-in-bag)	Primordia initiation	Fruiting body formation*		Crop cycle
			Cold temp. strains	Warm temp. strains	
<b>Temperature</b>	21-27 °C	10-16 °C	10-21 °C	16-27 °C	Every 2-3 weeks for 8-12 (16)weeks
<b>Light**</b>	50-100 lux	500-2,000 lux at 370-420nm	500-2,000 lux at 370-420nm		
<b>Humidity</b>	95-100% R.H./ Inside of the sealed bag	95-100% R.H.	60-80% R.H.		
<b>Oxygen through Fresh-Air exchange</b>	0-1 per hour	4-7 per hour	4-8 per hour		
<b>CO<sub>2</sub> tolerance</b>	> 10,000 ppm	< 1,000 ppm	< 1,000 ppm		
<b>Duration</b>	35-70 days (strain dependent)	5-7 days	5-8 days		

\*Fluctuations within the fruiting temperature ranges are beneficial to the development of the mushroom crop.

\*\*Light levels < 500 lux cause noticeable elongation of the stem.

## Production of Hua-gu, the Flower Shiitake

### Introduction

Prof. Yi Huang, whom I met in China in 1998, talked about his unforgettable experience of seeing hundreds of “flowers of shiitake” blooming all at once on a falling log when he was sent up the mountain for grass-root labors during the Cultural Revolution. He was so impressed by the sight, he decided right there and then to become a mushroom specialist.

Hua-gu, the flower shiitake, occurs spontaneously in nature under appropriate weather conditions during cold and dry winter months. It is not a characteristic of a particular genotype, not being a genetically inherent trait. On the contrary, hua-gu, the shiitake with an unique morphological flower-like cracking pattern on the cap, is produced artificially through manipulation of growth parameters. Hua-gu is produced at low humidity and cold temperature with fluctuation in temperature and humidity. Success in cultivation of hua-gu can bring growers considerable extra income in China. Model systems of hua-gu production can be found in Gutien county, Fujian province and Qingyuan county, Zhejiang province, in China. Hua-gu varies in quality. White hua-gu with deep and wide cracking grain and thick context (mushroom meaty part) ranks high on the grading scale, while dark tea-colored mushrooms with less pronounced cracking grain are regarded as inferior.



### The principle of hua-gu formation

During the formation of shiitake basidiocarps (fruiting bodies), under winter or winter-like conditions, when the young mushroom buttons reach 2-3cm in diameter, dry air and cold temperature force the pilial (cap) surface into dormancy. In such an adverse environment with drastic diurnal fluctuations of both temperature and humidity, a protective dry surface is formed on the young mushroom cap. Nonetheless, the inner portion continues to grow using water available from the substrate. When favorable growth conditions return, the surface grows at a retarded rate, while the inner portion develops at a normal pace. Under these conditions, shiitake mushroom buttons grow with alternation in dormancy and growth, and a considerable differential in the growth rate between the surface and the inner portion. In time, the rapid growth of the inner portion raptures the mushroom surface, producing a flower-like cracking pattern on the cap surface. The name, hua-gu means flower (hua) mushroom (gu) in Chinese.

### The crucial factors for producing hua-gu

Low humidity, cold temperature, drastic diurnal fluctuations in temperature and humidity, diffused light, short exposure to direct mild winter sunshine, and fresh air are all conducive to hua-gu formation. Hua-gu is best produced at high altitudes and northern regions where farmers can take advantage of natural environmental conditions.

### Selection of shiitake strains for hua-gu production

Growers should use low-temperature and high quality strains easily adaptable to grow at cold temperature for hua-gu production. Strains towards the lower temperature margin in the mid-temperature range can also be used.

Other examples of desirable strains for hua-gu production are: L-241-1, Jean-Yin #1, Yee-you #5, LCV141, Le 204, Le 13, 9101, 7402, 612, 9018, N-06. Strain characteristics should be thoroughly studied before cultivation. For fruiting outdoor, time of spawn-

ing should be coordinated with the maturation characteristics in order to benefit from the winter stimulation. For example, Strains L 241-4, 7402, N-06 are late maturing strains which should be inoculated early during March and April, while Yee-you #5, 9018, Le 204 are early to mid-maturing strains which should be inoculated in May-June.

**Table 11.** Selected strains of *Lentinula edodes* for flower shiitake formation (Luo, 2004)

Strain	Cultivation season	Fructing temperature (°C)	Duration*
939	Autumn	8-22	120-160 days
135	Spring	8-18	160-180 days

\* From inoculation to fructing

### Timely application of forcing hua-gu

It is important for farmers to treat young shiitake during the proper developmental stage, which is when the caps of the young mushroom buttons reach 2-3cm in diameter. If treated too early, when the mushroom buttons are smaller than 1.5cm in diameter, the fragile young mushroom buttons may die due to dehydration or freezing temperatures. If the treatments are applied too late, when the mushroom buttons have already reach 3.5cm in diameter or larger, the mushrooms do not respond readily, and only narrow and shallow cracking are formed, usually at the edge of the mushroom. The best season for applying hua-gu forcing lasts from November to the following March in Biyang, China.

**Hua-gu forcing technology** (Ting, 1994; Xu, 1998): Fruit in outdoor mushroom sheds. Subject young shiitake buttons of the proper developmental stage of 2-3cm in diameter to growth parameters as described (Table 12).

**Table 12.** Hua-gu forcing: Subject shiitake young buttons of 2-3cm in diameter to the following growth parameters.

<b>Dry air</b>	65% R.H., no misting or spraying of water
<b>Cold temperature</b>	8-12 °C
<b>Optimum</b>	5-15 °C
<b>Diurnal fluctuation of temperature</b>	10 °C; (in difference, desirable) Exaggerate the difference by using the covers during the day only
<b>Substrate moisture</b>	55% for controlled slow growth; inject water when too dry
<b>Short exposure to winter sunshine</b>	70% shading
<b>Proper drainage</b>	to maintain low humidity
<b>Line the ground with coarse sand</b>	already formed cracks on the mushroom cap can be re-sealed by new growth during rainy, cloudy or misty weather



**Figure 9.** Flower shiitake growing from sawdust bag

**Table 13.** Specific growth parameters for hua-gu formation (Luo, 2004)

Growth parameter	Spawn run	Primordia initiation	Fruiting
Relative humidity	65-70%	85%	70%
Air temperature	25 ℃ (18-22 ℃ if color changing)	18-22 ℃/8-12 ℃ day/night fluctuation	8-18 ℃ fluctuation
Light	None (sunshine if color changing)	1,000-2,000 lux	1,000-2,000 lux
Air (ventilation)	1-2 fresh air exchange per day	keep fresh air	keep fresh air
Duration	60-70 days	7-8 days	20-25 days

### Three stages of hua-gu formation (Z. B. Yu, 1998)

Yu uses the approach in Table 14 for hua-gu forcing. Stage 1. Pre-conditioning by cold temperature to hold the growth rate back at a slow pace. Directly expose young mushroom buttons to cold air outside the bags. This is an adaptation stage to harsh environment ahead, stage 2. Hua-gu forcing parameters, stage 3. Enhancing hua-gu formation. For a case study on hua-gu formation in outdoor mushroom sheds, refer to G. H. Lo (Ting, 1998). Air temperature, humidity and mushroom cap diameter were carefully monitored and recorded during the process of hua-gu formation.

**Table 14.** Three stages of hua-gu forcing by Yu (1998)

Stage 1. Pre-conditioning by low temperature. Subject shiitake of the proper developmental stage (from primordia to buttons of 2cm in diameter).	
Temperature	8-12 ℃
Humidity	85-90% R.H. (remains high)
Stage 2. Initiating hua-gu forcing when buttons reach 2-2.5cm in diameter.	
Temperature	15 ± 1 ℃ (8-18 ℃)
Humidity	50-67% R.H. (when < 47%, apply misting of water)
Substrate moisture	50-55%
Fluctuation of temperature and humidity	
Stage 3. Enhancing hua-gu formation when caps reach 3.5cm in diameter to maturation.	
Temperature	15-25 ℃
Humidity	55-65% R.H.

**Figure 10.** Flower shiitake **A:** Fresh flower shiitake **B** and **C:** Dried flower shiitake

## Conclusions

The current trend of shiitake production points to sawdust-bag cultivation. Growing shiitake in sterilized bags is gaining

popularity not only in Asian countries such as China, Taiwan, Singapore, the Philippines, Sri Lanka, and Thailand, but also in New Zealand, Australia, the U.S., Canada, Finland, France, the Netherlands and Germany (Oei, 2003). Growing interest is also evident in new markets in Mexico, Brazil (Renato *et al.*, 2004), Guatemala, and Peru. With the efforts of MushWorld towards encouraging shiitake cultivation as a means to alleviate poverty, it is anticipated that shiitake production will be further expanded to poverty-stricken warmer regions of the world, such as Africa and beyond.

Using shiitake bag cultivation instead of natural logs, mushrooms can be harvested faster, and the yield higher. Many types of organic wastes can be used to produce such valuable food through bioconversion. Mushrooms can be produced all year round to meet the market's demands. Shiitake bag cultivation is comparatively easier to manage and can be handled by workers, young and old, area as well as in urban districts.

It is evident that 1) shiitake varies in features and quality according to the strain, 2) different ways can be used for successful cultivation of shiitake. It is hoped that with the introduction of the practical knowledge and images presented in this review, readers will be inspired in their growing shiitake.

## REFERENCES

- Babcock, G. 2004. Reuse of substrate in specialty mushroom production. In: Romaine, Keil, Rinker and Royse, eds: *Mushroom Science XVI: Science and Cultivation of Edible Medicinal Fungi*. University Park, PA: The Pennsylvania State University Press. pp. 559-563.
- Chang, S.T. and P.G. Miles. 2004. *Mushrooms: Cultivation, Nutritional Value, Medicinal Effect and Environmental Impact*. 2<sup>nd</sup> ed. CRC Press.
- Chen, A.W. 2004. Growing shiitake mushrooms. In: *Mushroom Growers' Handbook 1: Oyster Mushroom Cultivation*. Seoul, Korea: MushWorld. pp 248-261.
- Chen, A.W. 2001. Cultivation of *Lentinula edodes* on synthetic logs. *Mushroom Growers' Newsletter* 10 (4): 3-9.
- Chen, A.W., N. Arnold, and P. Stamets. 2000. Shiitake cultivation systems. In: Van Griensven, ed: *Science and Cultivation of Edible Fungi*, pp. 771-778.
- Luo, X. C. 2004. Progress of xiang-gu (shiitake) cultivation in China. In: Romaine, Keil, Rinker and Royse, eds: *Mushroom Science XVI: Science and Cultivation of Edible Medicinal Fungi*. University Park, PA: The Pennsylvania State University Press. pp. 317-322
- Oei, Peter, 2003. *Lentinula edodes* (shiitake) cultivation on sterilized substrates (Hsu, Lou, 2003) on wood logs, in *Mushroom Cultivation*. 3<sup>rd</sup> ed. Leiden, the Netherlands: Backhuys. pp. 303-324, and 325-341.
- Renato, M.C. *et al.* 2004. Strains and substrate interaction on culinary-medicinal shiitake mushroom *Lentinula edodes* (Berk.) Singer (Agaricomycetiae) axenic sawdust cultivation in Brazil. *International Journal of Medicinal Mushrooms* 6 (2): 173-180.
- Royse, D. 2002. *Cultivation of Shiitake on Natural and Synthetic Log*. University Park, PA: The Pennsylvania State University Press.
- Stamets, P. 2000. *Growing Gourmet and Medicinal Mushrooms*. Berkeley, CA: Ten Sped Press.
- Ting, H. G. 1994. *New Technology of High-yield and Fast Production of Shiitake*. Beijing, China: Golden Shield Press (in Chinese).
- Wu, J.L. ed. 2000. *Shiitake Production in China*. Beijing, China: Agricultural Press (in Chinese).
- Wu, S.Y., J.H. YU, Z.W. Wu, G.J. Yu, D.S. Wu, H.F. Zhun, Y.F. Wu, and J.J. Ye. 1995. The volume-growth analyses of fourteen tree species for shiitake mushroom. In: Luo, X.C. and M. Zang, eds: *The Biology and Technology of Mushroom*. Beijing, China: China Agricultural Sciencetech Press. pp. 34-39.
- Xu, Q.C. 1998. New Technology for Breeding Bi-Yang Flower Mushroom. In: Lu, M.L., K. Gao, F. Si, and M.J. Chen, eds: *Science and Cultivation of Mushrooms*. Nanjing, China: JSTC-ISMS. pp. 32-35.
- Yu, Z.B. 1998. Bi-Yang Model System for Shiitake Synthetic Log Cultivation (in Chinese).

## Part I Shiitake

## Chapter 4

Shiitake Bag Cultivation

## Further Reading

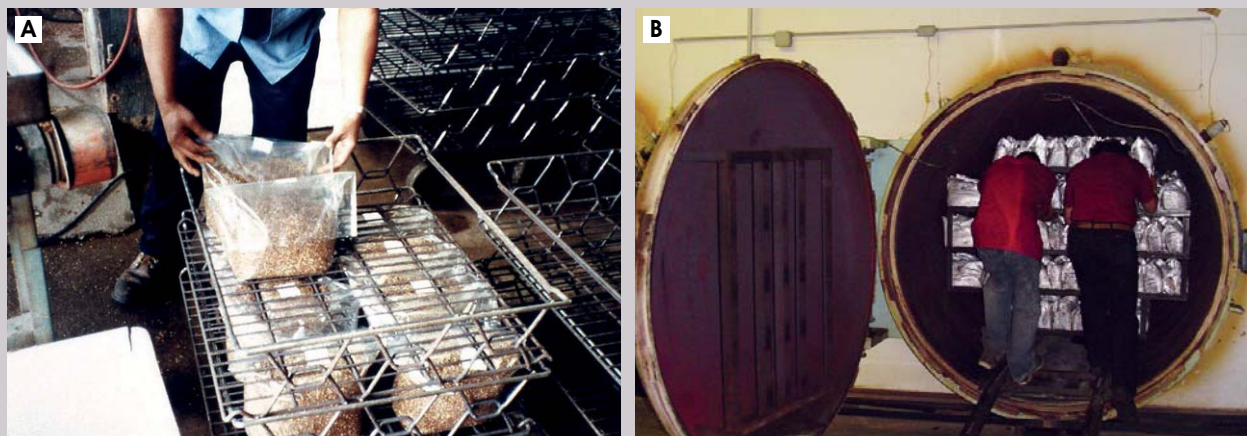
## ■ Shiitake Bag Cultivation in the U.S.

Daniel J. Royse<sup>1</sup> and Qing Shen<sup>2</sup><sup>1</sup>The Pennsylvania State University, University Park, PA 16802, the U.S. (djr4@psu.edu)<sup>2</sup>Kennett Square Specialties, the U.S.

The major advantages of producing shiitake on sawdust bags compared with producing shiitake on natural logs are: consistent market supply through year-round production, increased yields, and decreased time required completing a crop cycle. The cycle for supplemented sawdust block cultivation lasts approximately 3 months from time of inoculation to cleanout. Biological efficiencies for nutrient supplement substrate average from 75% to 125%. In contrast, the natural log cultivation cycle usually lasts about 6 years with maximum efficiencies around 33%. The time required on sawdust substrate is about 6% of the natural system with about 3 times the yield efficiency. These advantages far outweigh the major disadvantages of a relatively high initial investment cost to start a sawdust block manufacturing and production facility. As a result of these developments, shiitake production in the United States has increased dramatically in the last 10 years.

**Substrate preparation**

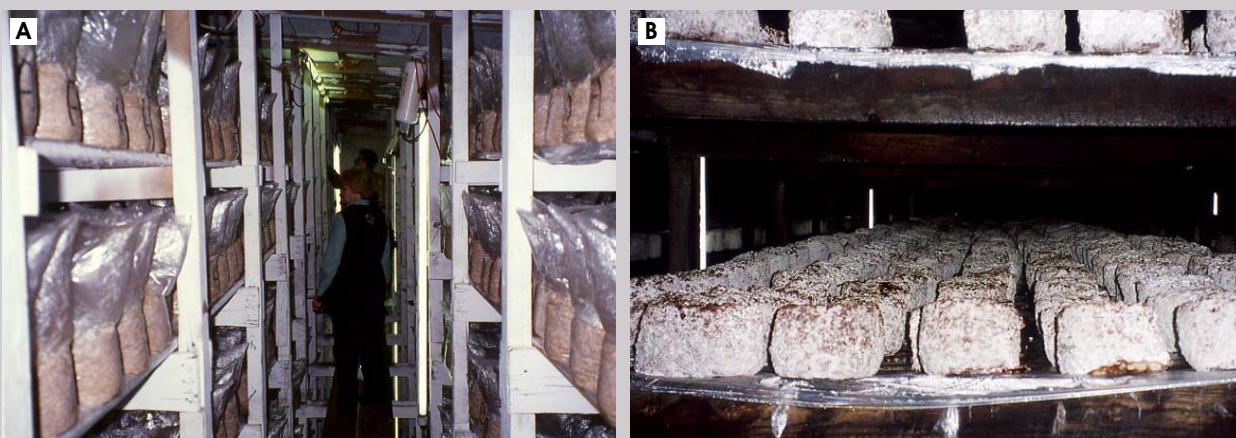
Sawdust is the most popular basal ingredient for shiitake bag cultivation in the U.S.. Starch-based supplements (10-60% dry weight) such as wheat bran, rice bran, millet, rye, and maize are added to the mix. These supplements serve as nutrients to provide an optimum-growing medium. Other supplements, added in lesser quantities include CaCO<sub>3</sub>, gypsum, and table sugar. The ingredients are combined in a mixer and water is added to raise the moisture content of the mix to around 60%. Bags are made of heat resistant polypropylene and contain a breather patch made of microporous plastic. The filled bags are stacked on racks (Fig. 1A), loaded into an industrial-sized autoclave (Fig. 1B), sterilized for 2 hours at 121 °C, cooled in a clean room and inoculated with shiitake spawn. The bags then are heat-sealed and the spawn is through-mixed (evenly distributed) into the substrate by mechanical or hand shaking. An alternative method of substrate processing and spawning is to heat-treat, cool, inoculate and aseptically bag the substrate in the same machine.



**Figure 1.** Sterilization **A:** Stacking of supplemented substrate contained in microporous filter bags onto autoclave carts. Tops of bags are folded over so that adjacent bags do not cover patches that allow for gas exchange. **B:** Workers moving carts containing shiitake medium in bags into large autoclaves.

### Spawn run and browning

If through mixing of the spawn (2-3% of wet substrate weight) into the sterilized substrate is used, a 20-25 day spawn run at 21 °C (4 hours light per day) is all that is required (Fig. 2A). With this method, the bags are removed from the substrate after completion of spawn run and the substrate blocks are exposed to an environment conducive for browning (oxidation of surface mycelium, also called skin formation by growers) of the exterior block surfaces. The browning process allows the mycelium on the log surface to aggregate and toughen thereby forming a layer of hyphae that is resistant to desiccation. During the browning period (4 weeks) shiitake blocks are maintained at a temperature of 19 °C while CO<sub>2</sub> levels are maintained at 2,200-3,000ppm (Fig. 2B). Maintaining CO<sub>2</sub> at these levels requires less energy use (less heating or cooling of fresh air) and promotes faster browning of the block surfaces. Sawdust blocks may be watered lightly 1-3 times per day to maintain continuous surface moisture which helps to facilitate the browning process. Excessive watering, however, will cause the surface mycelium to turn black, an undesirable consequence that may reduce yield at a later stage. Blackening of the surface mycelium may be the result of bacterial growth with subsequent loss of the protective nature of the hardened mycelium. Many growers have learned to properly brown the exterior surfaces of the blocks using only humidification control. As the browning process nears completion, primordia begin to form about 1-2mm under the surface of the log and as the primordia enlarge, cracks (called "staring" by growers) may form in the protective hyphal layer. Staring (forming star like cracks) is a good indication that the block is ready to be soaked and to produce mushrooms. If through mixing of the spawn is not used, a spawn run of 45-90 days in the bag is necessary to achieve proper spawn run and browning.



**Figure 2.** Spawn run and browning **A:** Spawn run in substrate contained in microporus filter bags stacked on shelves in a standard Pennsylvania double (800m<sup>2</sup>). Bags are spaced approximately 1 cm apart to facilitate air movement and cooling. **B:** Colonized substrate blocks on shelves 8 days after removal of bags. To enhance browning (oxidation) of substrate surfaces, water (mist) is applied 1-3 times daily.

Browning outside of the bag has some advantages and disadvantages over browning inside the bag. Browning outside of the bag produces a firmer, more resilient sawdust blocks that will resist breakage during soaking, harvesting and handling. In addition, browning outside the bag allows use of more productive strains that may cause blistering of the substrate if browning is completed inside the bag. Blistering is a condition wherein the outer surface of the log may buckle and develop air pockets that tend to flake off when removed from the bag. Browning outside the bag reduces the tendency for blocks to blister. Yields and mushroom quality tend to be higher when sawdust blocks are browned outside the bag. The disadvantage of browning outside the bag is the additional management required (watering 2-3 times per day and maintenance of higher relative humidity) so that block surfaces do not dry out. If log surfaces dry out, *Trichoderma* spp. may begin to colonize the desiccated hyphae and bits of exposed substrate.

### Fruiting and harvest

To stimulate maturation of primordial when browning is completed, blocks may be soaked in water (12 °C) for 3-4 hours. For blocks that are browned inside the bag, soaking on the first flush is not required because sufficient water is available to support the first flush of mushrooms. However, soaking of sawdust blocks is required for the second and



**Figure 3.** First-flush shiitake maturing on synthetic logs made from nutrient supplemented sawdust. After spawn run and browning, blocks are soaked and placed on shelves.

subsequent flushes. Soaking allows water to rapidly displace carbon dioxide contained in substrate air spaces, and provides enough moisture for one flush of mushrooms. After soaking, blocks are placed on shelves and mushrooms begin to enlarge. Approximately 7-11 days after soaking, mushrooms are ready to harvest (Fig. 3). Mushrooms are twisted from the surface and the residual substrate is sometimes removed with a knife or scissors to provide for a cleaner product. After all mushrooms have been harvested from the substrate, the blocks again are soaked in water. The second soaking may require up to 12 hours and the third soaking may require up to 18 hours to replace the water lost through production of mushroom tissue and through evaporation. The average time from the peak harvest of one flush to the peak of the next flush is about 18 days.

## SOURCES FOR FURTHER READINGS

- Chang, S.T. 1999. World production of cultivated edible and medicinal mushrooms in 1997 with emphasis on *Lentinus edodes* (Berk. Sing in China. *International J. Med. Mush.* 1: 291-300.
- Ito, T. 1978. Cultivation of *Lentinus edodes*. In: Chang, S. T., and W. A. Hayes, eds: *The Biology and Cultivation of Edible Mushrooms*. New York: Academic Press.
- Lee, E. 1996. Production of shiitake, oyster and maitake mushrooms in Connecticut. *Mushroom News* 42(3): 11-14.
- Mizuno, T. 1995. Shiitake, *Lentinus edodes*: functional properties for medicinal and food purposes. *Food Rev. Int.* 11: 111-128.
- Oei, P. 2003. *Mushroom Cultivation: Appropriate Technology for Mushroom Growers*. Leiden, The Netherlands: Backhuys Publishers. 429 pp.
- Przybylowicz, P., and J. Donoghue. 1988. Shiitake growers handbook. Dubuque, Iowa: Kendall/Hunt Publishing Company.
- Royle, D.J. 1995. Specialty mushrooms: cultivation on synthetic substrate in the USA and Japan. *Interdisciplin. Sci. Rev.* 20: 205-214.
- Royle, D.J. 1996. Yield stimulation of shiitake by millet supplementation of wood chip substrate. *Mush. Biol. Mush. Prod.* 2: 277-283.
- Royle, D.J. 1997. Specialty mushrooms and their cultivation. *Hort. Rev.* 19: 59-97.
- Royle, D.J. 2001. *Cultivation of Shiitake on Natural and Synthetic Logs*. University Park, PA: College of Agricultural Sciences, The Pennsylvania State University. 11 pp.
- Royle, D.J., and J. E. Sanchez-Vazquez. 2001. Influence of substrate wood-chip particle size on shiitake (*Lentinula edodes*) yield. *Bioresource Technol.* 76: 229-233.
- Royle, D.J., and J.E. Sanchez-Vazquez. 2003. Influence of precipitated calcium carbonate (CaCO<sub>3</sub>) on shiitake (*Lentinula edodes*) yield and mushroom size. *Bioresource Technol.* 90: 225-228.
- Royle, D.J., L.C. Schisler, and D.A. Diehle. 1985. Shiitake mushrooms: consumption, production and cultivation. *Interdisciplin. Sci. Rev.* 10: 329-335
- Royle, D.J., T.W. Rhodes, and J.E. Sanchez. 2002. Vacuum soaking of wood chip shiitake (*Lentinula edodes*) logs to reduce soak time and log weight variability and to stimulate mushroom yield. *Appl. Microbiol. Biotechnol.* 58: 58-62.
- Shen, Q., Q. Tan, and D.J. Royle. 2004. Growing *Lentinula edodes* and other mushrooms in China—a low input technology alternative. *Revista Mexicana de Micología* 18: 15-20.
- Stamets, P. 2000. *Growing Gourmet and Medicinal Mushrooms*. Berkeley, CA: Ten Speed Press.
- United States Department of Agriculture (USDA). 1993-2004. *Mushrooms*. National Agricultural Statistics Service. Washington, DC.

## Part I Shiitake

## Chapter 4

Shiitake Bag Cultivation**ALTERNATIVE SUBSTRATE FOR SHIITAKE**

One of the benefits of mushroom bag cultivation is that various agro-industrial wastes can be utilized like coffee residues, sugarcane bagasse, corncob, cotton waste, sunflower seed hulls, cereal straws, sawdust, and so on, according to local availability. Many underdeveloped regions are located in tropical or sub-tropical areas producing plentiful agricultural wastes from various plantations. These wastes are easy to obtain locally, so very cheap or sometimes free. Mushroom cultivation can generate a new income source by utilizing these pollutants and relatively cheap labor in these regions. It makes mushroom growing very attractive and effective means to make a living for the people in these areas. Most mushrooms can make use of the largest variety of waste substrates thanks to their enzyme that can biodegrade various types of available wastes.

Shiitake has been regarded less adaptable to various substrate materials and sawdust or wood chips are main substrate materials for shiitake bag cultivation. However, many trials and success have been in identifying alternative substrate materials for shiitake. This identification of alternative shiitake substrate is very meaningful, by which wastes and pollutants are converted into a new income source for poverty alleviation. Various research papers report possible substrate materials for shiitake growing such as coffee husk, coffee pulp, spent coffee ground, sugarcane bagasse, corncob, millet straw, wheat straw, tea leaves, peanut hulls, cotton seed hulls, sunflower seed hulls, dried grass powder, water hyacinth, and so on. If these resources are locally available, shiitake can be grown from them, bringing about quick return and high profits. However, it should be kept in mind that different treatments are exploited for different substrate materials due to their distinct characteristics. Therefore, growers should understand characteristics of a selected material beforehand, especially when non-conventional substrate material is selected for shiitake cultivation. The alternative substrate also requires spawn that can run rapidly with competitive advantage on that particular substrate. Four of alternative substrate materials for shiitake will be reviewed regarding their characteristics, nutritional contents, appropriate treatment, and productivity.



## Part I Shiitake

## Chapter 4

Shiitake Bag Cultivation**COFFEE RESIDUES**Leifa Fan<sup>1</sup>\* and Carlos R. Soccol<sup>2</sup><sup>1</sup>Horticultural Institute, Zhejiang Academy of Agricultural Sciences, Hangzhou, 310021, P.R. China \*(fanleifa@yahoo.com.cn)<sup>2</sup>Departament of Chemical Engineering, Federal University of Parana, Brazil

Enzymes in the shiitake metabolism allow the fungi to degrade and use cellulose, hemicelluloses and various quantities of lignin for their nutrition. Among agricultural by-products available for use in shiitake cultivation, coffee residues are one of the most potentially importance substrates because million tons of coffee residues are produced every year in more than 50 countries. However, due to the presence of substance unfavorable for mushroom growing including caffeine, tannins and polyphenols, these residues have not been utilized beneficially and their disposal is a serious concern for the processing units.

**Coffee Residues as an Alternative Substrate**

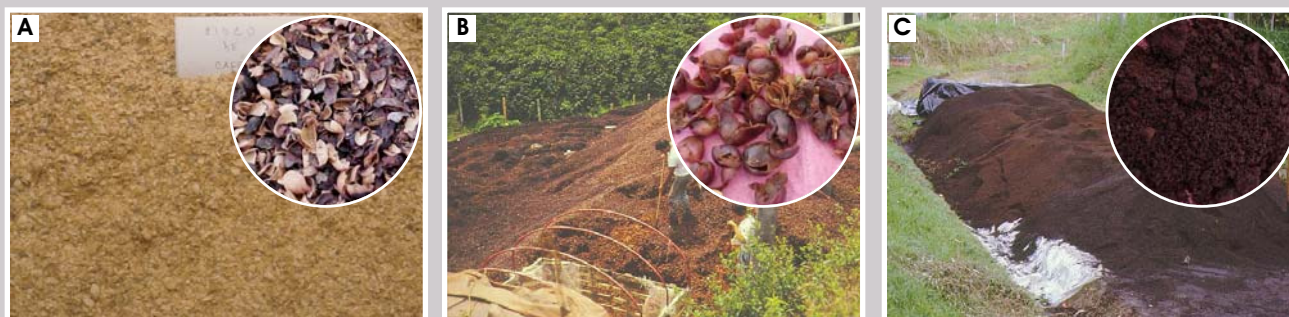
There are several different coffee residues, including coffee husks, coffee pulp and spent grounds. Coffee husk is produced in the dry process of the separation of the coffee berries while coffee pulp is obtained by the wet process of extracting coffee from the berries. Spent coffee grounds are produced during the processing of raw coffee powder to prepare instant coffee. The nutrition and harmful substances of main coffee residues are shown in the Table 1.

**Table 1.** Nutrition and harmful substances in coffee residues (%)

Component	Coffee husk	Coffee pulp	Coffee spent ground
Protein	9.2-11.3	8.5-12.1	10.3-12.2
Lipids	2.0-2.3	1.5-2.0	15.2-17.9
Cellulose	13.2-27.6	15.1-20.3	13.2-18.4
Ash	3.3-4.1	5.5-6.8	4.5-6.3
Extract not-nitrogen	57.8-66.1	45.5-54.3	41.0-49.8
Tannins	4.5-5.4	1.8-2.4	1.2-1.5
Caffeine	0.8-1.1	0.5-0.7	0.02-0.08

Note : The value varies according to the coffee species and processes.

Unfortunately, the coffee husk and pulp have large amounts of caffeine and tannins, and the harmful substances, especially caffeine, have a negative effect on mushroom growth and inhibit the growth of mushroom mycelium. While coffee residues are highly nutritious, most do require treatment before used as substrate for shiitake cultivation and the costs of pre-treating coffee husk and pulp can hinder their wide usage. Spent coffee grounds are the exception and do not require a caffeine removal processing stage (Thielke, 1989).



**Figure 1.** Coffee residues **A:** Coffee husk **B:** Coffee pulp **C:** Coffee spent ground (Photo courtesy of Carmenza L. Jaramillo)

## Pre-treatment of Coffee Residues

The pretreatment of coffee residues, especially coffee husk and pulp, aims at detoxification and removal of the most caffeine possible. Among the several possible methods for caffeine removal, the most frequently chosen are filtration with boiling water, degradation by fermenting microorganisms, and bioremediation using with *Pleurotus* spp.

### The boiling water method

The coffee husks or pulp are boiled in water for 15 minutes, and then the water is drained off. The residues can then be used for the shiitake cultivation. This method is efficient, but it does generate a large amount of water with harmful substances. It is thought that some potentially nutritious components are lost through boiling, but no specific research has been done on this specific possibility.

### The use of fermentating microorganisms

There are many microorganisms, such as *Rhizopus arrizus*, *Phanerochaete* and *Aspergillus* spp., which can partially degrade the caffeine and tannins, achieving reductions of 65-92% for caffeine and 45-65% for tannins (Brand *et al.*, 2000, 2001 and 2002; Pandey *et al.*, 2000). One week of fermentation after inoculation can suffice for this process.

### Bioremediation with *Pleurotus* spp.

The *Pleurotus* mushroom has a strong ability to degrade or absorb some harmful substances. It has been reported that *Pleurotus* can be used to absorb caffeine from substrate materials because this fungus can accumulate caffeine in the fruiting bodies and thereby diminish the caffeine content in the coffee residue substrate. According to the research (Fan *et al.*, 2000a), the fruiting body of *Pleurotus* can contain 0.157% caffeine while the raw coffee has 1% caffeine. The accumulated caffeine in the fruiting body is generally acceptable because most consumers are accustomed to drinking coffee. The harvested oyster mushrooms could perhaps be marketed as a new product with a stimulating effect and the coffee residues in the spent *Pleurotus* substrate could then be utilized for shiitake production. Certainly some addition of supplements would be required before the second use, as the oyster mushrooms would also consume some of the basic nutrition in the substrate.

## Shiitake Bag Cultivation with Coffee Residue

### Formula

Treated coffee residues are good substrates for shiitake cultivation, but they make loose bags when used alone. For this reason coffee residues are usually supplemented with some additional cellulosic substrates such as sawdust and rice or wheat bran in order to create a desirable texture for filling shiitake bags. The formula used is shown in Table 2.

### Filling the bag

Polyethylene or polypropylene plastic bags 25-35cm long and 15-20cm wide are used. All materials are weighed and prepared according to the formula, then mixed evenly with clean water at a ratio of 1:1.2. The water content is then adjusted to 55%, a level suitable for filling the bags. The mixture is packed into plastic bags easily, neither tightly nor loosely. Generally, the bags should contain half a kilogram of dried substrate. Once filled, they are tied with string or covered with cotton and a neck ring.

**Table 2.** Formulae of shiitake bag cultivation using coffee residues

Formula	Main substance	Nitrogen source	Supplementation
1	Coffee husk 50%, Sawdust 29%	Wheat or rice bran 20%	Gypsum 1%
2	Coffee pulp 50%, Sawdust 28%	Wheat or rice bran 20%	Gypsum 1%, Calcium superphosphate 1%
3	Coffee husk 50%, Coffee spent ground 29%	Wheat or rice bran 20%	Gypsum 1%
4	Coffee pulp 40%, Coffee spent ground 39%	Wheat or rice bran 20%	Gypsum 1%

Note: The formula can be adjusted according to local resources.

### Sterilization

After filling, the bags are transferred to a special steaming room and sterilized at 97℃ for 8~10 hours, or put in an autoclave for 2 hours at 1.1kg/cm<sup>2</sup>. If the bags are sterilized in an autoclave, the strings should be tied loosely or the bag should be perforated and covered with a filter. On the second day, when the temperature has dropped to 60℃, the bags are taken out and put into an inoculation room that has been cleaned in advance and prepared for cooling during the inoculation period.

### Spawning

Spawn is generally bought from reliable suppliers, and inoculation is conducted under a flush lamina desk or in an inoculation box equipped with a UV light. Inoculation can be performed when the bags have cooled to the point that the temperature at the bag surface is less than 25℃. The bags can be inoculated either at the sealed side or the other, according to preferences of each farm.

### Management at mycelial growth stage

During the spawn run, attention should be paid to maintaining a constant temperature around the bags. Substrate bag piles should be turned after one week in order to even the temperature for each tier of bags. When the white mycelia cover the whole surface of the bags (Fig. 2), the bags should be carried into the fruiting house.



**Figure 2.** Coffee residue substrate bag fully colonized by shiitake mycelia



**Figure 3.** Shiitake fruiting bodies from coffee residues (Photo courtesy of Gerardo Mata)

### Management at fructification stage

Growers are advised to move the fully colonized bags to growing house and arrange them there for fructification. The growing house should be covered by plastic and shade netting that allows some natural light to come through. When the color of substrate surface turns from light brown to dark brown and yellow water droplets appear, it is the time for primordial induction. About one week later, the primordia will start to form. After the fruiting bodies grow to 2cm in diameter, they can be watered directly overhead. There will be 4 or 5 flushes in total (Fig. 3). If the substrate is immersed in water for 1 or 2 days, in some cases another flush or two are possible.

In experiments the biological efficiency of this production can reach 90% (Fan *et al.*, 2000b), but farmers can usually harvest 0.3 to 0.5kg of fresh shiitake mushrooms from 1kg of dried substrate.

## REFERENCES

- Brand, D., A. Pandey, J.A. Rodriguez-Leon, S. Roussos, I. Brand, and C.R. Soccol. 2001. Packed bed column fermenter and kinetic modeling for upgrading the nutritional quality of coffee husk in solid-state fermentation. *Biotechnol. Prog.* 17(6): 1065-1070.
- Brand, D., A. Pandey, J.A. Rodriguez-Leon, S. Roussos, I. Brand, and C.R. Soccol. 2002. Relationship between coffee husk caffeine degradation and respiration of *Aspergillus* sp. LPBx in solid-state fermentation. *Appl. Biochem. Biotechnol.* 102-103(1-6): 169-177.
- Brand, D., A. Pandey, S. Roussos, and C.R. Soccol. 2000. Biological detoxification of coffee husk by filamentous fungi using a solid state fermentation system. *Enzyme Microb. Technol.* 27(1-2): 127-133.
- Fan, L., A. Pandey, R. Mohan, and C.R. Soccol. 2000a. Use of various industry residues for the cultivation of *Pleurotus ostreatus* in solid state fermentation. *Acta Biotechnology* 20: 41-52
- Fan L., A. Pandey, R. Mohan, and C.R. Soccol. 2000b. Solid state cultivation: an efficient method to use toxic agro-industrial residues. *J. Basic Microbiol.* 40: 187-197.
- Pandey, A., C.R. Soccol, P. Nigam, D. Brand, R. Mohan, and S. Roussos. 2000. Biotechnological potential of coffee pulp and coffee husk for bioprocesses. *Biochem. Eng. J.* 6(2): 153-162.
- Thielke, C. 1989. Cultivation of edible fungi on coffee grounds. *Mushroom Science* 12: 337-343.

## Part I Shiitake

## Chapter 4

Shiitake Bag Cultivation

## GRASS

Zhanxi Lin

JUNCAO Research Institute, Fujian Agriculture &amp; Forestry University, Fuzhou city, Fujian, China (lzxjuncao@163.com)

Translated by Dongmei Lin

Shiitake has traditionally been cultivated on tree-based materials such as logs and sawdust, and the tree resources have been over-exploited in many areas partly due to the fast growth of mushroom industry. As an alternative, various grass species have been researched as effective substrates for the cultivation of shiitake and other mushrooms. To date, several grass species have been selected as suitable mushroom substrates and among them, six species are recommended for shiitake cultivation. The Juncao Research Institute has named these selected grass species Juncao, which literally means 'Fungi grass.'

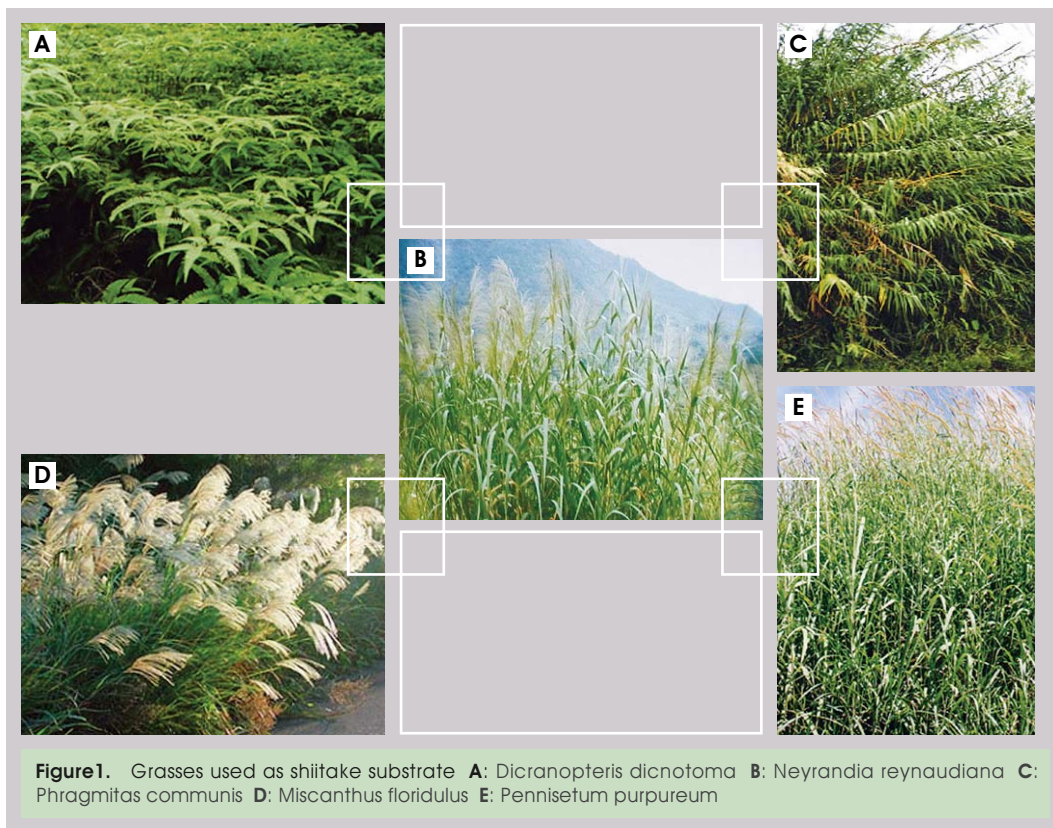
### Grass as an Alternative Substrate

The test results of the Fujian Agriculture University Central Laboratory show that the nutrient content of most grass species is richer than those of broadleaf tree sawdust (Table 1). Specifically, the protein content of wild *Dicranopteris dicnotoma*, *Neyrandia reynaudiana*, *Saccharum arundinaceum*, *Phragmitas communis*, *Miscanthus floridulus*, and *Themeda gigantea* is 2-4 times that of sawdust. Their fat, nitrogen, phosphorus, potassium and magnesium contents are 101-216%, 232-353%, 225-685%, 346-908%, 191-303% of those of mixed sawdust from broadleaf trees.

Mushrooms cultivated with the selected grasses have higher nutrition contents than those with sawdust or logs. It can be seen from Table 2 that mushrooms that are cultivated with grass substrates have higher nutritional values than those cultivated with sawdust or logs.

**Table 1.** Nutrients contents of grass species (%)

Nutrients Contents	Protein	Fiber	Fat	N	P	K	Ca	Mg
Mixed sawdust from broadleaf trees	1.19	84.82	0.93	0.19	0.02	0.11	0.22	0.03
<i>Dicranopteris dicnotoma</i>	3.75	72.10	2.01	0.60	0.09	0.37	0.22	0.08
<i>Neyrandia reynaudiana</i>	4.42	58.80	1.72	0.67	0.14	0.96	0.26	0.09
<i>Saccharum arundinaceum</i>	2.75	62.50	0.99	N/A	0.12	0.76	0.17	0.09
<i>Phragmitas communis</i>	3.19	72.50	0.94	0.51	0.08	0.85	0.14	0.06
<i>Miscanthus floridulus</i>	3.56	55.10	1.44	0.57	0.08	0.90	0.30	0.10
<i>Themeda gigantea</i>	3.85	51.1	1.38	0.61	0.05	0.72	0.19	0.08
<i>Pennisetum purpureum</i>	5.91	68.88	N/A	N/A	0.18	0.78	0.40	0.24
<i>Spartina atierniflora</i>	9.90	23.58	2.96	N/A	N/A	N/A	N/A	N/A
<i>Sorghum propinquum</i>	4.17	49.47	N/A	N/A	0.08	0.46	0.44	0.17



**Figure 1.** Grasses used as shiitake substrate **A:** *Dicranopteris dichotoma* **B:** *Neyrandia reynaudiana* **C:** *Phragmitas communis* **D:** *Miscanthus floridulus* **E:** *Pennisetum purpureum*

**Table 2.** Comparison of nutritional value of fruiting bodies grown in different substrate

Constituents	<i>Lentinula edodes</i>			<i>Auricularia polytricha</i>			<i>Auricularia auricula</i>	
	Juncao	Sawdust	Log	Juncao	Sawdust	Log	Juncao	Sawdust
Protein (%)	32.836	28.787	19.65	8.212	7.997	7.376	17.832	9.861
Fiber (%)	20.4	17.12	29.81	27.75	19.61	39.8	21.33	13.66
Fat (%)	2.31	2.61	1.71	1.4	0.8	1.2	0.87	0.47
Ash (%)	9.42	8.02	9.55	9.55	9.62	9.71	9.57	9.48
N (%)	5.254	4.606	3.145	1.314	1.28	1.18	2.853	1.578
P (%)	0.965	0.855	0.378	0.228	0.195	0.19	0.356	0.36
K (%)	1.944	1.447	1.372	1.066	0.829	0.696	1.562	1.69
Ca (%)	0.013	0.033	0.023	0.108	0.099	0.249	0.141	0.176
Mg (%)	0.143	0.132	0.137	0.148	0.133	0.136	0.128	0.177
Fe (ppm)	101.95	75.12	78.6	98.05	136.37	248.6	42.09	100.99

## ■ Preparation of Grass-based Substrate

Due to the different biological character of the grass, its pretreatment, harvesting, processing and storage are different from those of sawdust. The three handling steps outlined below help growers realize the full potential of the selected grasses' nutritional value.

### Harvesting

Due to the high nitrogen content of *Dicranopteris dicnotoma*, *Neyrandia reynaudiana* and other grasses, the harvesting season and weather must be chosen carefully. If grass is harvested during rainy days, drying and powdering is more difficult and mildew can cause less of the grass to be useable. Therefore, harvesting must take place during 5-7 sunny days. Harvesting time depends on which grass is harvested and which mushrooms will be cultivated on it. For example, *Dicranopteris dicnotoma* can be cropped during the whole year, though it is best harvested from May to July. The optimal harvesting time for *Neyrandia reynaudiana*, *Miscanthus floridulus* is during the flowering and heading stages. However, *Neyrandia reynaudiana* for cultivation of shiitake or wood ear (*Auricularia polytricha*) and *Auricularia peltata* should be harvested after heading and aging.

### Drying

After cropping, grasses must be dried thoroughly in sunlight, and this process is always affected by the weather. Growers are advised to store dried grasses before the rainy season. Two storage methods are commonly employed: indoor storage in dry rooms and outdoor haystack storage. For outdoor storage, waterproof coverings are required. For both methods, great care must be taken for fire-prevention. Loose grasses normally occupy large spaces indoors, and they are easily dampened outdoors, so the grasses should be processed into powder immediately after drying. Powdered grass in a small volume is more convenient than raw grass for both storage and long distance transport.

### Powdering

Special grinders are required to powder dried grass. The size of the grinder sieve also depends upon the different grass species. For example, a sieve whose holes are of diameter about 2.5mm is used for *Dicranopteris dicnotoma* while a sieve with holes of a diameter of 3.0-3.5mm is usually suitable for *Neyrandia reynaudiana*. Grass powder must be stored in dry rooms or it will become mildewed or blocked, which will exhaust the nutrients and lower the nutritional value of the powdered grasses.

## ■ Shiitake Bag Cultivation with Grass-based Substrate

### Grass composition for shiitake growing

The composition of grass-based shiitake substrate depends on the local conditions. Growers might want to utilize readily available and abundant grass species in their area. The following composition is recommended as shiitake substrate based on the research results of Juncao Research Institute of Fujian Agricultural University in China.

- 1) *Dicranopteris dicnotoma* 38%, *Miscanthus floridulus* 40%, wheat bran 20%, gypsum powder 2% (appropriate in warm and moist area).
- 2) *Miscanthus floridulus* 48%, *Dicranopteris dicnotoma* or *Pennisetum purpureum* 30%, wheat bran 20%, gypsum powder 2% (appropriate in forest area).
- 3) *Dicranopteris dicnotoma* 23%, *Neyrandia reynaudiana* 20%, *Saccharum arundinaceum* 20%, *Phragmites communis* 20%, wheat bran 15%, gypsum powder 2%.
- 4) *Neyrandia reynaudiana* 53%, *Dicranopteris dicnotoma* 30%, wheat bran 15, gypsum powder 2%.

### Strain selection

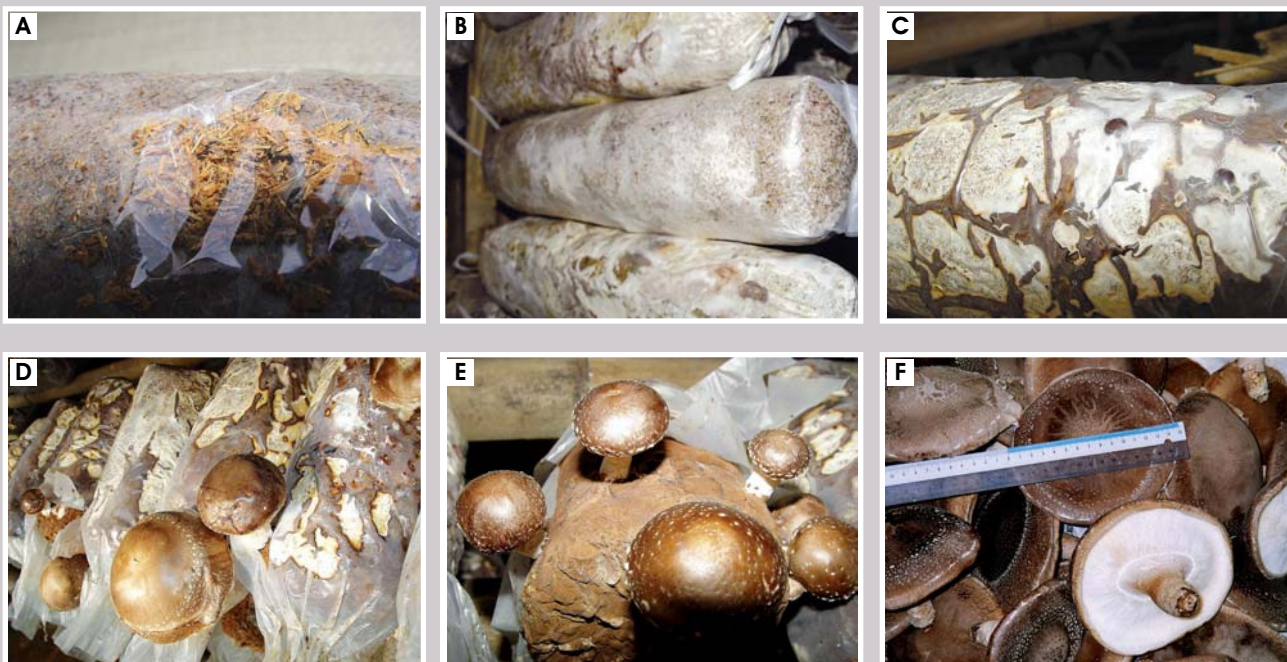
For this non-conventional substrate, new mushroom strains that are appropriate for the new substrate should be selected and improved. Juncao Research Institute has worked on this project, and a list of suitable strains for grass substrate cultivation is provided in Table 3. The yield and quality of shiitake mushrooms differ greatly according to strains though cultivated in the same area and with the same substrate material. Similarly, the same strain gives very much different results if cultivated in different areas or with different substrate material. Therefore, strains must be chosen based on the local climatic conditions and resources, and the quality of the strains should be carefully examined.

**Table 3.** Various strains of shiitake grown in grass-based substrate

Strain No.	Temperature type	Fruiting temperature (°C)	Size of fruiting bodies
LC214	Fairly high	11 - 15	Large
LC216	Fairly high	10 - 24	Medium-large
LC265	Fairly high	10 - 24	Large
LC202	Middle	10 - 21	Medium
LC206	Middle	8 - 21	Medium
LC207	Middle	8 - 21	Small-medium
LC236	Middle	9 - 21	Medium-large
LC109	Fairly low	7 - 20	Medium-large
Jinxuan No. 1	High	14 - 26	Medium-large
Jinxuan No. 2	High	13 - 26	Medium-large
Jinxuan No. 3	Low to middle	7 - 19	Medium
Jinxuan No. 4	Low	5 - 17	Medium

### Shiitake cultivation with grasses at a glance

The growing method of shiitake with grass substrate is not much different from that with sawdust. Due to the tendency of higher water absorption and loss, however, much attention should be paid to grass substrates in order to keep appropriate humidity and water content of substrate for each stage. When watering, it should be kept in mind that grass substrates absorb water more rapidly than sawdust substrates.



**Figure 2.** Shiitake cultivation with grass-based substrate **A:** Inoculation hole **B:** Mycelium growing **C:** Primordia formation and buttoning **D** and **E:** Fruiting development **F:** Sizable fruiting bodies

## Part I Shiitake

## Chapter 4

Shiitake Bag Cultivation

## WHEAT STRAW

Gerardo Mata<sup>1</sup> and Jean-Michel Savoie<sup>2</sup><sup>1</sup>Unidad de Micología, Instituto de Ecología, Apdo. Postal 63, Xalapa 91000, Ver., Mexico (gerardo\_mata 2000@yahoo.fr)<sup>2</sup>Institut National de la Recherche Agronomique (INRA), France

Traditional log cultivation of shiitake has been partly replaced by bag cultivation with sterilized sawdust due to this method's higher biological efficiency, and shorter production cycle. However, the sterilization process has a high initial installation cost, consumes more of energy, and is more susceptible to contamination (Kalberer, 1998). To solve these problems, pasteurized (65 °C) wheat straw substrate has been adopted for shiitake cultivation in Europe (Delpech and Olivier, 1991) and in some countries of America (Mata *et al.*, 2002).

### ■ Wheat Straw as an Alternative Substrate

Mushrooms such as shiitake are able to oxidize the lignin-polysaccharide complex of cereal straw without prior chemical or biological treatment.

Wheat straw substrate for shiitake cultivation has two considerable advantages over other agricultural by-products such as coffee pulp or sugarcane bagasse: a) wheat straw is stocked easily without problems of decomposition or fermentation; and b) contamination by moulds and bacteria is less frequent than other substrates due to the unique chemical composition of the wheat straw.

Straw being a crop residue, its chemical composition and degradation rate appear to be controlled by both genetic factors and cultural practices (Savoie *et al.*, 1994). Though some differences exist according to species and how long they are stored, the nutrition of wheat straw, rice straw, and coffee pulp used for shiitake cultivation are generally analyzed as shown in Table 1.

**Table 1.** Nutrition of wheat straw, rice straw and coffee pulp (mg / 100g of dry substrate)

Composition	Wheat straw*	Rice straw**	Coffee pulp**
Protein	7.9	9.0	10.2
Carbon	52.5	N/A	N/A
C/N	41.0	N/A	N/A
Lignin	8.6	5.7	21.0
Cellulose	35.2	33.9	36.4
Hemicellulose	N/A	26.8	5.1

\* Gaitán-Hernández and Mata 2004

\*\* Vega *et al.*, 2005



Figure 1. Cereal straw A: Wheat straw B: Rice straw

## Shiitake Bag Cultivation with Wheat Straw

### Substrate preparation

This process aims to prepare a substrate and bring it to a with favorable condition for the growth of shiitake mycelia. This is called the selectivity of substrates, and both the composition of the substrate materials and the heat treatments have a great effect on the substrate selectivity.

Wheat straw is shredded into pieces from 4 to 6cm in length for easy handling during pasteurization and bagging (Figs. 2). It is soaked in water for 6-12 hours at room temperature and mixed with 2 to 10% (dry weight) of gypsum. Several supplements containing materials that are lacking in wheat straw itself are added to provide sufficient nutrients for the shiitake mycelia. As a nitrogen and oligoelements source, soja flour added at 4kg per ton can increase the yield by 30%, but soja flour is more likely to lower substrate selectivity. Generally, substrate selectivity decreases by addition of components rich in nitrogen or oligoelements. Therefore, it is recommended to either add only a small quantity of them, or to sterilize the substrate if a large amount of the nitrogen rich components are added. Other supplements improve the competitiveness of shiitake against *Trichoderma* sp. Peat, sawdust or other water-soluble lignin derivatives not only have absorbing properties but also contain phenolic compounds that most competitors cannot degrade easily. Shiitake can degrade these soluble lignin with oxidative enzymes, so the shiitake mycelia have almost exclusive access to these supplements (Mata *et al.*, 2001; Savoie *et al.*, 2000). When 10% peat moss is added, the contamination rate by *Trichoderma* is decreased by 50% and the yield is increased by 30% (Mata *et al.*, 1998).

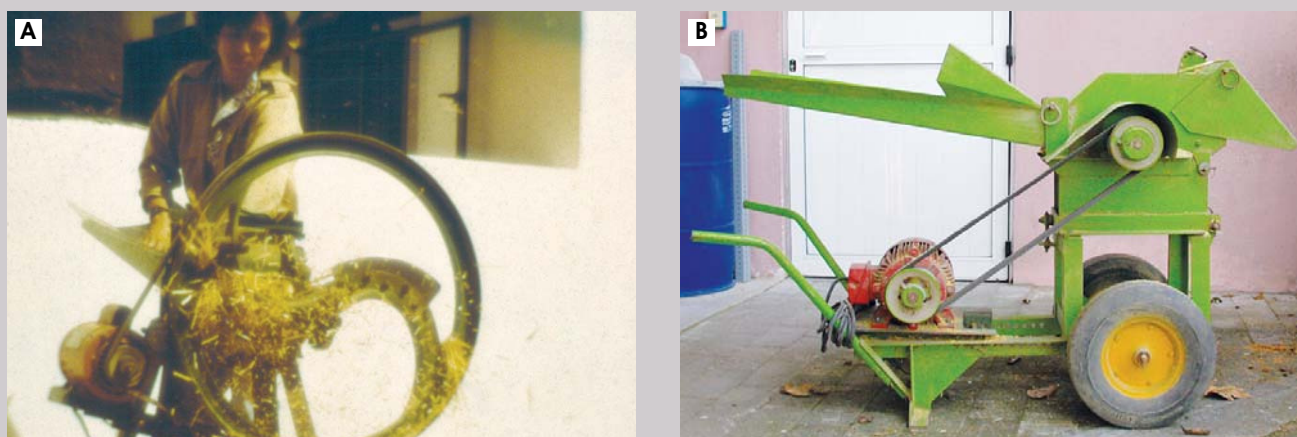


Figure 2. Different machines for cutting wheat straw

### Pasteurization

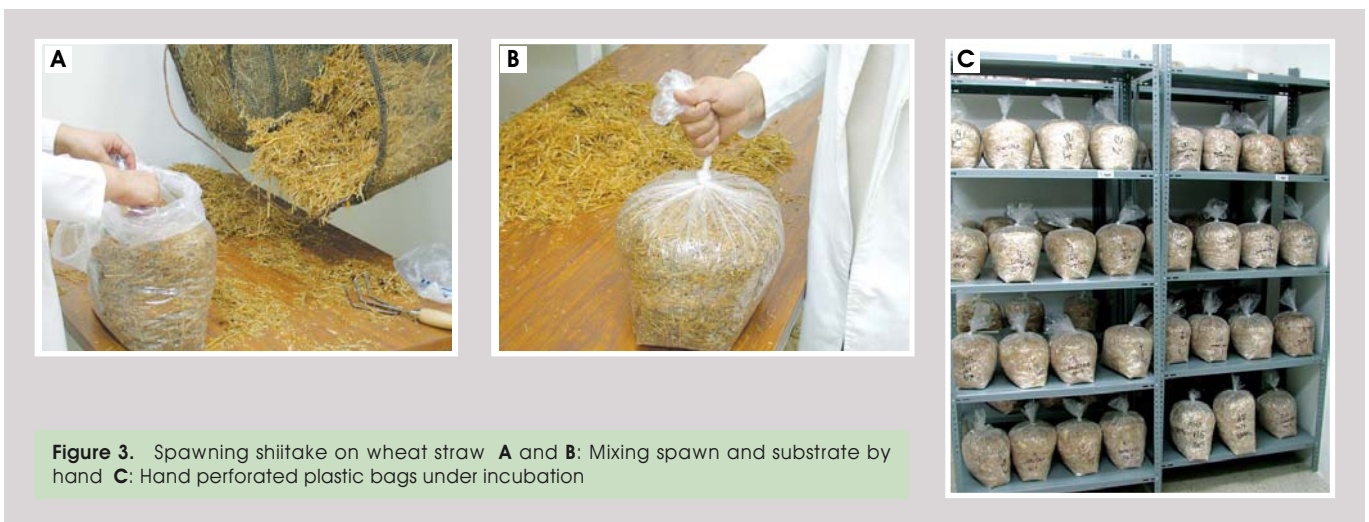
Wheat straw is pasteurized in order to kill possible competitor microorganisms as well as insects in the straw. Another goal of pasteurization is to propagate the thermophilic microorganisms that will improve the substrate selectivity by immobilizing the readily available nutrients to competitors and by producing toxic or inhibitory molecules to limit the rapid growth of competitors.

The substrate mixture is placed in containers for pasteurization with steam at 65 °C for 12-24 hours and then cooled to room temperature. Water content of the substrates after pasteurization is about 70% (Mata *et al.*, 1998).

### Spawning and incubation

The selection of genotypes appropriate for the chemical and structural properties of chosen substrates and thermal treatments are critically important to ensure a good production of fruiting bodies in the shortest time possible. Though the number of shiitake strains that are well adapted to pasteurized wheat straw is relatively low (Mata and Savoie, 1998), it is recommended that wheat straw using growers choose the shiitake strain with competitiveness in wheat straw.

After cooling, the pasteurized substrates are mixed with spawn in a clean environment. Aseptic conditions are not necessary because the substrate is not sterilized. In order to improve the competitiveness of shiitake during the first days after spawning, the mycelium in the spawn has to be vigorous, adapted to the components of the substrate and able to colonize all the particles of the substrate<sup>1</sup>. For these reasons, Delpuch and Olivier (1991) recommended limiting the use of supplementation in wheat straw substrates to prevent the growth of bacteria and moulds. Spawn must be mixed with sterilized or pasteurized straw at 5-7% (w/w) and the mixture should be placed in plastic bags that are lightly perforated or equipped with a microporous filter (Figs. 3A and B). Incubation is one of the most important phases in the shiitake cultivation on alternative substrates because of the competition between shiitake and competitor moulds that occurs during the first weeks. The initial rate of substrate colonization by the antagonistic fungi is an important factor of the competitive interaction. If shiitake rejects the attack by the mould at this stage, no other problem is encountered afterward. Some strains of shiitake are able to reject the mould attacks under temperature and nutritive conditions favorable to them (Badham, 1991) and if their mycelium has colonized enough space before contacting competitor fungi (Savoie *et al.*, 1998). Incubation must be carried out at 25 ± 2 °C with a 12 hours light and 12 hours dark cycle, which is recommended at least for shiitake cultivation on wheat straw, for



1–2 months depending on the strain (Fig. 3C). At the end of incubation period, the entire surface of substrate turns brown, indicating that mycelium is ready for fructification (Przybylowicz and Donoghue, 1988; Donoghue and Dennison, 1996).

### Obtained production on wheat straw

When incubation is completed, the plastic bags are removed and the substrate blocks are sprinkled with cold water. The room temperature is lowered to 17 ± 1 °C. A relative humidity of 90% and a cycle of 12 hours light / 12 hours dark are necessary to encourage mushroom development. After the farm has harvested the first flush, the blocks can be rehydrated to induce a second flush by soaking them in water for 12 hours (Gaitán-Hernández and Mata, 2004) (Figs. 4). Under commer-

<sup>1</sup> For detailed information, see IMPROVEMENT OF SPAWN FOR CULTIVATION IN ALTERNATIVE SUBSTRATES in Chapter 2.

cial production conditions, when large blocks of supplemented and pasteurized straw are used (16kg), harvest can be performed for 12-16 weeks and biological efficiency reaches 50-100%. Table 2 provides some research results on biological efficiency obtained from wheat straw as well as other alternative substrates for shiitake. Though the same substrate is used, biological efficiency varies depending on the conditions of cultivation. Moreover, it should be kept in mind that conditions such as strains, temperature and humidity provided during cultivation are different in each experiment referred in Table 2. Wheat straw and sugarcane bagasse inoculated with supplemented spawn produce a high biological efficiency (Salmones *et al.*, 1999; Savoie *et al.*, 2000).

**Table 2.** Comparison of shiitake biological efficiencies obtained on different substrates

Substrate	Heat treatment	Spawn	Biological efficiency (%)	Reference
Wheat straw	Pasteurization with steam	Conventional	59.2	Mata and Savoie, 1998
		Conventional	15.9	Delpech and Olivier, 1991
		Supplemented	59	Mata <i>et al.</i> , 1998
		Supplemented	116	Savoie <i>et al.</i> , 2000
	Pasteurization in hot water	Supplemented	55.6	Gaitán-Hernández and Mata, 2004
Coffee residues	Sterilization	Conventional	88.6	Leifa <i>et al.</i> , 1999
		Conventional	64.3	Mata and Gaitán-Hernández, 1994
Sugarcane bagasse	Sterilization	Conventional	133.4	Salmones <i>et al.</i> , 1999
Sugarcane leaves	Sterilization	Conventional	97.8	Salmones <i>et al.</i> , 1999
Bracts of pineapple	Sterilization	Conventional	37.5	Salmones <i>et al.</i> , 1999



**Figure 4.** Shiitake fruit bodies production on wheat straw **A:** Pins with dark cap on the substrate surface **B:** Young fruiting bodies **C:** Commercial production of shiitake **D** and **E:** Mature shiitake fruit bodies

## REFERENCES

- Badham, E.R. 1991. Growth and competition between *Lentinus edodes* and *Trichoderma harzianum* on sawdust substrates. *Mycologia* 83: 455-463.
- Delpech, P., and J.M. Olivier. 1991. Cultivation of shiitake on straw based pasteurized substrates. *Mushroom Science* 12: 523-528.
- Donoghue, J.D., and W.C. Denison. 1996. Commercial production of shiitake (*Lentinula edodes*) using whole-log chips of *Quercus*, *Lithocarpus* and *Acer*. In: Royse, D.J., ed: *Mushroom Biology and Mushroom Products*. Penn State University, University Park. pp. 265-275.
- Gaitán-Hernández R., and G. Mata. 2004. Cultivation of the edible mushroom *Lentinula edodes* (shiitake) in pasteurized wheat straw: Alternative use of geothermal energy in Mexico. *Engineering in Life Sciences* 4: 363-367.
- Kalberer, P. 1998. Influence of the substrate components on the crop yield of shiitake (*Lentinus edodes* (Berk.)Singer). *Gartenbauwissenschaft* 63: 15-19.
- Leifa, F., A. Pandey, and C.R. Soccol. 1999. Growth of *Lentinus edodes* on coffee industry residues and fruiting body production. In: Broderick, A., and T. Nair, eds: *Mushroom Biology and Mushroom Products*. WSMBMP, Sydney. pp. 285-292.
- Mata, G., and J.M. Savoie. 1998. Extracellular enzyme activities in six *Lentinula edodes* strains during cultivation in wheat straw. *World Journal of Microbiology and Biotechnology* 14: 513-519.
- Mata, G., J.M. Savoie, P. Delpech, and J.M. Olivier. 1998. Reduction of the incidence of *Trichoderma* spp. using substrate supplementation with peat and an alternative spawn during cultivation of *Lentinula edodes* on pasteurized wheat straw. *Agronomie: Agriculture and Environment* 18: 515-520.
- Mata, G., P. Delpech, and J.M. Savoie. 2001. Selection of strains of *Lentinula edodes* and *Lentinula boryana* adapted for efficient mycelial growth on wheat straw. *Revista Iberoamericana de Micología* 18: 118-122.
- Mata, G., and R. Gaitán-Hernández. 1994. Avances en el cultivo del shiitake en pulpa de café. *Revista Iberoamericana de Micología* 11: 90-91.
- Mata, G., R. Gaitán-Hernández, R. Pérez-Merlo, and C. Ortega. 2002. Improvement of shiitake spawn for culturing on pasteurized wheat straw. In: Sánchez, J.E., G. Huerta, E. Montiel, eds: *Mushroom Biology and Mushroom Products*. Cuernavaca, Mexico: UAEM. pp. 303-309.
- Oei, P.. 1991. Some aspects of mushroom cultivation in developing countries. *Mushroom Science* 13: 777-780.
- Przybylowicz, P., and J. Donoghue. 1988. *Shiitake Growers Handbook: The Art and Science of Mushroom Cultivation*. Dubuque, Iowa: Kendall/Hunt Publishing Company.
- Salmones, D., G. Mata, L. M. Ramos, and K. N. Waliszewski. 1999. Cultivation of shiitake mushroom, *Lentinula edodes*, in several lignocellulosic materials originating from the subtropics. *Agronomie* 19: 13-19.
- Savoie, J.M., G. Mata, and C. Billete. 1998. Extracellular laccase production during hyphal interactions between *Trichoderma* spp. and shiitake, *Lentinula edodes*. *Applied Microbiology and Biotechnology* 49: 589-593.
- Savoie, J.M., N. Minvielle, and N. Chalaux. 1994. Estimation of wheat straw quality for edible mushroom production and effects of a growth regulator. *Bioresource Technology* 48: 149-153.
- Savoie, J.M., P. Delpech, C. Billete, and G. Mata. 2000. Inoculum adaptation changes the outcome of the competition between *Lentinula edodes* and *Trichoderma* spp. during shiitake cultivation on pasteurized wheat straw. In: Van Griensven, L.J.L.D. ed: *Science and Cultivation of Edible Fungi*. Rotterdam, the Netherlands: A.A. Balkema. pp. 667-674.
- Vega, A., R.E. Caballero, J.R. García, and N. Mori. 2005. Bioconversion of agroindustrial residues by *Pleurotus ostreatus* cultivation. *Revista Mexicana de Micología* 20: in press.

## Part I Shiitake

## Chapter 4

Shiitake Bag Cultivation**SHIITAKE BAG CULTIVATION IN THAILAND**Mungkom Thevasingh<sup>1</sup>, Wanchai Pale<sup>2</sup> and Kyung Wha Choi (Ivy)<sup>3</sup><sup>1</sup> Chiang Mai University, 239 Huay Kaew Road, Chiang Mai 50200, Thailand (greenfusant@yahoo.com)<sup>2</sup> Wanchai Farm, Thailand<sup>3</sup> MushWorld, Korea

Thailand has been involved in commercial mushroom production since the 1930's (Singh, 1998). Support has come from both government and private agencies for programs that encourage development in rural areas. The increasing demand for mushrooms in the canning and processing industry has also caused an increase in mushroom cultivation. The annual Thai mushroom production is valued at more than THB<sup>1</sup>10,000 million (USD260 million) (Phanuthat, 2001). In Thailand, mushrooms are primarily sold in supermarkets and restaurants in the capital and other tourist areas. As the tourism and hotel business expands in Thailand, the mushroom consumption per capita also increases. Shiitake is one of the most popular, flavorful, and expensive mushrooms in the Thai markets. Shiitake cultivation in Thailand started in Chiangmai in the northern part of Thailand using wood logs. Log cultivation was one of the contributors to undesirable of forest exploitation, so the Thai government encouraged shiitake farmers to change to bag cultivation using sawdust. Shiitake is one of the most profitable mushroom crops in Thailand due to its relatively high price. Thai people usually consume fresh shiitake rather than dried. Shiitake that are not sold fresh are sent to food processing factories to be made into sauces, crackers, and other preserved products.



**Figure 1.** Substrate bags incubated in evaporative cooling room

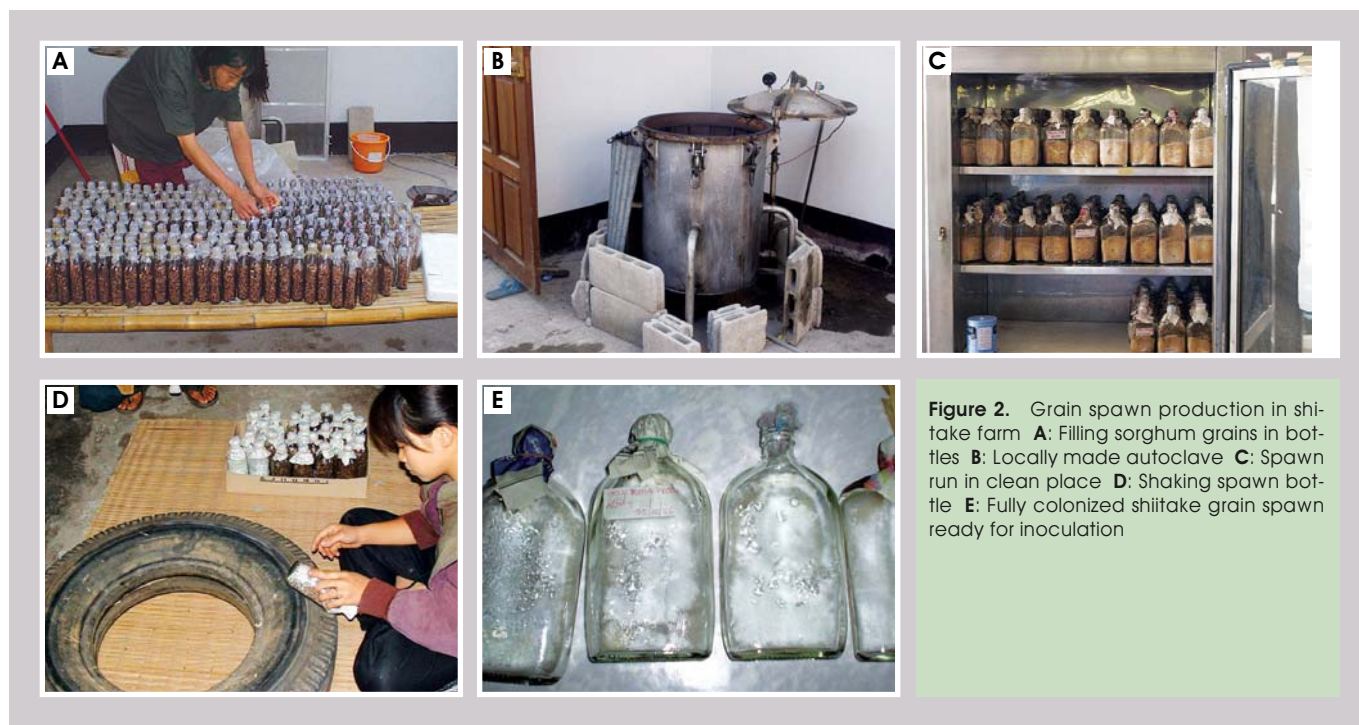
Shiitake grows well in the lower temperatures of the northern Thailand region where the winter temperature is 18-25 °C. This is a good climate for the mycelial growth of shiitake and the coolness decreases the pest fungi contamination rates. Shiitake can be cultivated all year round, but the yield is distinctly higher in the cool seasons and cool areas. Therefore, most shiitake growers prepare substrate bags in June and incubate the bags for 4 months and get fruiting bodies in cool winter, November to February. While they don't grow shiitake in hot summer, March to May. On the other hand, while large scale farms equipped with cooling system (fan and pad cooling system<sup>2</sup>) prepare shiitake bags in summer in order to get fruiting bodies in rainy season with relatively cool temperature (Fig. 1). Shiitake prices drop as low as THB100-160 (USD2.61-4.16) per kg at retail during the rainy season (June-October) because of the low demand caused by the combination of abundant wild mushrooms and low tourist activity in this season. The retail price during dry season (November-May) varies from THB120-240 (USD3.12-6.24) per kg according to the markets where shiitake is sold: village market, town market, supermarket and so on.

### Shiitake Grain Spawn

<sup>1</sup> THB (Thai Baht, USD1 = THB38.46 in March, 2005)

<sup>2</sup> For detailed information on fan and pad cooling system, see SHIITAKE GROWING HOUSES IN THAILAND AND THEIR MANAGEMENT in Chapter 6.

Most shiitake farms in Thailand utilize grain spawn<sup>3</sup> because grain spawn colonizes substrates relatively rapidly and it is easy to use when inoculating the bags. Some farms that are troubled with rats that enjoy eating grain will utilize sawdust spawn instead in order to avoid rat damage. Many farms purchase spawn from supplier, but some large farms produce spawn for their own use. The production process of grain spawn is as following. Sorghum grains are filled into the medium-size Maekhong whiskey bottle and the bottle is plugged with cotton and covered with paper pieces (Fig. 2A). The grains are sterilized in low cost autoclave made from iron and then cooled and inoculated with inoculum (Fig. 2B). The bottles are incubated for spawn run in clean place (Fig. 2C). The recommended procedure is to shake the grain spawn bottle during spawn run and before inoculation (Fig. 2D). The recommended procedure is to shake the grain spawn bottle during spawn run and before inoculation (Fig. 2D).



**Figure 2.** Grain spawn production in shiitake farm **A:** Filling sorghum grains in bottles **B:** Locally made autoclave **C:** Spawn run in clean place **D:** Shaking spawn bottle **E:** Fully colonized shiitake grain spawn ready for inoculation

## Shiitake Cultivation Steps

### Substrate: para rubber tree sawdust

Shiitake grows well from *Castanopsis* or *Quercus* logs. These trees play an important role in forest and soil water reservation, so cutting down these trees is prohibited in Thailand. Therefore, para rubber tree (*Hevea brasiliensis*) sawdust is used as an alternative substrate for shiitake cultivation in Thailand, and the results are satisfactory. The rubber tree sawdust is a waste product from the local furniture industry. Every year many rubber-exhausted trees are cut down to make way for new planting in the southern part of Thailand and these logs are then used as raw materials for the furniture industry. A large quantity of sawdust waste is collected in ten-wheel trucks and then transported to northern Thailand where it is used for shiitake cultivation. The price of rubber tree sawdust is about THB16,000 (USD416) per truckload of 13 tons. One truck of sawdust is sufficient to produce between 13,000 and 15,000 substrate bags (0.7-1.0kg/bag).

### Substrate preparation

Rubber tree sawdust is usually left outdoor for 1-2 months for fermentation before being used, in order to get rid of volatile toxic gases. Gases emitted during spawn run could harm or kill the shiitake mycelia. After the outdoor fermentation, the dried sawdust is pre-wetted with clean water and is left on a concrete floor overnight and some supplements are added. The usual composition of the substrate material in Thailand is shown in Table 1.

**Table 1.** Formulation of shiitake substrate

Materials	Quantity
Sawdust	100kg
Rice bran (fine)	5kg
Sugar	2.3kg
Magnesium sulfate	0.2-0.5kg
Water	65 l

<sup>3</sup> For detailed process of grain spawn making, see SHIITAKE SPAWN PREPARATION CHIEFLY WITH SAWDUST in Chapter 2.

Though the process of substrate preparation varies depending on farms, a shiitake farm in Chiangmai prepares substrate using the methods described here. This farm adds several supplements such as lime, calcium nitrate, and vitamin B<sub>1</sub> to their regular formulation. The sawdust is first screened to get rid of big particles or chips which could potentially perforate plastic bags (Figs. 3). This process is important because perforation of the bags could easily allow contamination during spawn run.



**Figure 3.** Sawdust screening **A:** Screening sawdust **B:** Screening machine and sorted big particles

100kg of sawdust is spread on the floor and rice bran is added at 3-5% of the weight of sawdust (Fig. 4A). One kg of lime and 2-3kg sugar are also scattered on the sawdust (Fig. 4B). One kg calcium nitrate, 0.2 kg magnesium sulfate, and 0.05kg vitamin B<sub>1</sub> are dissolved, and the solution is sprinkled on the sawdust (Fig. 4C). The supplements are all thoroughly mixed with the sawdust (Fig. 4D). More water is added to raise the moisture content to 60-65% and the sawdust is mixed again (Figs. 4E and F).



**Figure 4.** Substrate preparation **A:** Adding rice bran to sawdust **B:** Scattering lime and sugar **C:** Dissolving calcium nitrate, magnesium sulfate, and vitamin B<sub>1</sub> **D:** Mixing materials thoroughly **E:** Adding water **F:** Mixing materials

### Bagging and sterilization

700-1,000g of the mixed substrate is put into each clear, heat-resistant plastic bag (7 inch × 11 inch). Some shiitake farms fill substrate bags manually, putting mixed substrate material into a bag and then compacting the substrate by hitting it with a rod or bottle (Fig. 5A). Compacting is not a difficult job, so it can be performed by several workers. Some larger scale

farms use a compacting machine that presses the substrate into the bags (Fig. 5B). The machine saves a great deal of time, and is highly recommended for large farms. A plastic ring is inserted as a bottle neck and the mouth is sealed with cotton plug and then wrapped with a square piece of newspaper.



**Figure 5.** Bag filling and compacting **A:** Manual filling and compacting with rod **B:** Compacting bags with machine

Filled bags are sterilized in an oil drum with steam. Water is poured into the bottom of the drum and metal grates are placed inside the drum to hold up the bags in each layer (Figs. 6A and B). Usually 100 bags are sterilized in a 200 l oil drum at 90-100 °C for 3-4 hours (Fig. 6C). Many farms consume hardwood sawdust or logs as fuel. The structures of the fireplace for the oil drum are different based on which fuel is used. The fireplace for sawdust has quite a distinctive structure. Sawdust is poured into the fireplace and the fire burns under the drum. As the sawdust at the bottom burns up, the upper sawdust slides into the fire place. Figure 6D shows fire place full of sawdust and as the sawdust burns up, it shrinks as shown in Figure 6E. The fireplace structure for logs is designed to fit that specific fuel (Fig. 6F).



**Figure 6.** Sterilization of bags in oil drum **A:** Inside oil drum (there is water under the metal grate) **B:** Metal grate holding bags up in each layer of drum **C:** Oil drum filled with bags **D:** Substrate sterilization in a big drum (fuel-sawdust) **E:** The structure of fire hole for small drum **F:** Fireplace for logs

### Inoculation

When sterilization is completed, the bags are moved to a cooling room and cooled to the ambient temperature at 30℃ (Fig. 7A). Grain spawn is inoculated into the cooled bags. Several grains are poured into the bag and it is wrapped again with a cotton plug and newspaper. It is recommended that the spawning environment be kept very clean, so many farms have separated the inoculation process and it is performed in after disinfecting the inoculation room with 70% alcohol before inoculation. Some farms inoculate spawn in a somewhat open environment (Fig. 7C). The inoculation environment does affect the contamination rate.



### Spawn run

Most shiitake farms in Thailand incubate shiitake bags for spawn running on the ground though some farms do so on shelves. Before being filled with inoculated bags, the ground of a growing house is limed to prevent green mold (Fig. 8A). The bags are incubated at 25-28℃ for 2-4 months. White shiitake mycelia grow from bottle necks where grain spawn was placed to the bottom (Fig. 8B). After being fully colonized, the shiitake bags turn brown (Fig. 8C), and they are ready for fruiting induction when browning is completed. It takes 48-51 days for full colonization by shiitake mycelia in the bags and 114-118 days until fruiting initiation after inoculation.



### Primordial induction

The bags are exposed to lower temperatures and higher humidity to induce fruiting. The bags are opened by removing the plastic necks and the upper part of the bag is cut (Figs. 9A and B). And then the bags are inverted on wet ground for 2-3 days. Because the ground has more moisture and is of a lower temperature, the shiitake mycelia in the bags experience a sudden change of temperature and moisture. They are turned upright again after 2-3 days (Fig. 9C). The bags are covered with wet sacks, followed by a watering in order to wet the bags thoroughly. In winter with relatively low temperatures, fruiting is induced by keeping the bags at 18-25℃ and in 90-100% humidity under plastic sheet or wetted sacks for 3-4 days. In summer, water in a bucket is cooled to 7-10℃ by adding ice, and then this cold water is used to provide a low temperature shock. Alternatively, small pieces of ice are sprinkled on top of the bags and the bags are covered with wetted sacks for 3-4

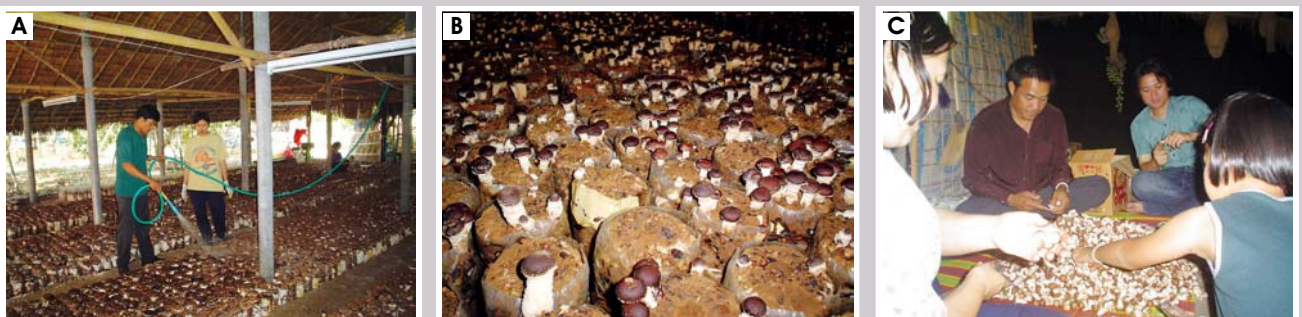
days. Some farms stimulate fruiting by beating the top of substrate with a sandal after cutting the upper plastic bags, and then providing lower temperature and high humidity as described above (Fig. 9D).



**Figure 9.** Primordial induction **A:** After getting rid of neck and ring **B:** Cutting top of plastic bags **C:** Brownish surface **D:** Beating the top of the substrate

### Fruiting and harvesting

When small white primordia appear, the sacks are removed and the bags are watered 2-3 times per day. Shiitake is very sensitive to the level of CO<sub>2</sub> during fruiting, and the formation and development of fruiting bodies is inhibited by high concentrations of CO<sub>2</sub>. Poor ventilation during fruiting body development causes the elongation of stems and slows cap enlargement. Watering is not recommended 6-12 hours before harvest. Growers allow the fruiting bodies to grow until the edge of caps partly separate from the stems. After the first flush, the substrates rest for 7-14 days and then the next flush is induced again by repeating the stimulation. Usually 3-5 flushes are harvested, with an average of total yield of about 100-150g per bag, over the course of 2~3 months. The harvested shiitake is trimmed, graded, and packed, and then preserved under cool

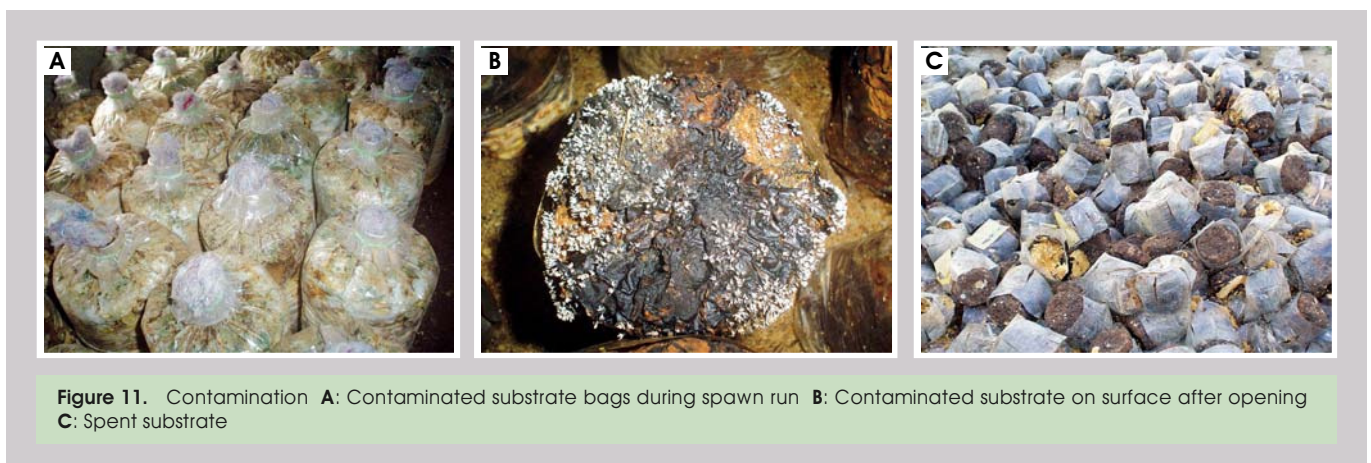


**Figure 10.** Fruiting and harvesting **A:** Watering **B:** Fruiting body growing **C:** Grading before packaging

conditions that can be as low as 7°C. Shiitake can be kept fresh for about one week under these conditions. Fresh shiitake is much preferred to dried in Thailand, so it is very important to preserve the freshness of the shiitake. The shelf life of shiitake can be extended by wrapping with paper before storing in a refrigerator.

### Pathology considerations

Outbreaks of pests and diseases can be extremely damaging, especially if contamination occurs early in the cropping cycle. To maintain pest and disease-free farms, farm hygiene must be maintained. It is crucial that bags are properly sterilized and growing houses are properly managed so as to avoid unnecessary introduction of contaminants to the growing houses. Even the smallest flies and gnats as well as contaminated bags must be removed as quickly as possible. After harvesting 3-5 flushes, the weight of the substrate in a bag shrinks to 300g, the length shrinks by 1-2 inches and the yield declines to an uneconomic level. The spent substrate is recycled as an organic soil matter to gardeners and horticulturists, being given away free or sold for the very low price of THB100-200 (USD2.60-5.20) per 1.5 ton truckload (Fig. 11C).

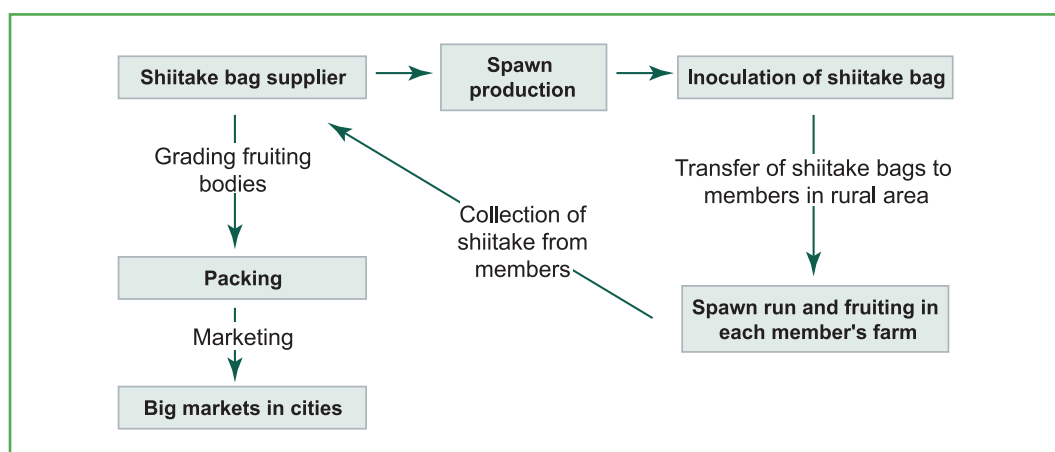


**Figure 11.** Contamination **A:** Contaminated substrate bags during spawn run **B:** Contaminated substrate on surface after opening **C:** Spent substrate

## Shiitake Bag Supply System

### How it works

Shiitake bag supply system has proven to be very effective method to support large scale shiitake cultivation as a group. Figure 12 shows how this system works. The bag supplier provides inoculated bags to its members and the bags are colonized by shiitake mycelia and produce fruiting bodies on the members' farms. Harvested shiitake from many farmers is



**Figure 12.** Operating system of shiitake bag supply

brought to the supplier, and then the supplier grades, packs, and markets the products to customers in the large urban areas.

The constant availability of fresh shiitake is a prerequisite for becoming a supplier in any of the big markets in Thailand. Because wholesalers and retailers demand a constant supply, farmers need to group together in order that the production

from many farms may allow supplying fresh shiitake continuously. This system has benefits not available through large scale commercial farms. The growing houses in this system are owned by each farmer, so a large investment to build many growing houses is not required. Moreover, each individual farmer bears the responsibility for his or her own shiitake crops. If the shiitake bags are well managed, the farmer can earn money by selling the shiitake to the bag supplier. On the other hand, the farmer earns little if the bag culture is badly managed. In addition, scattered shiitake farms do not have the same risk of accumulated diseases and insects like a very large scale shiitake farm do. The small farmers who cultivate pre-inoculated bags also benefit by getting a quicker return of capital than if they themselves had to perform the whole process of shiitake cultivation.

Shiitake is more suitable for a central bag supply system than other mushrooms such as oyster mushrooms. The relatively high price of shiitake motivates growers to invest and join this system which gives such quick returns. The fruiting bodies of shiitake have longer shelf life than other mushrooms, and this also induces some growers to choose shiitake cultivation. There are several shiitake bag suppliers in northern Thailand. Some deliver fully colonized bags to farmers while others deliver partly colonized bags. Among them, the farm A will be illustrated below.

The farm A is a large shiitake bag supplier with about 400 members in Chiangmai. The price of a bag is THB5(USD0.13) or more, depending on the distances of the farms. The shiitake bags are delivered right after inoculation in winter, but delivered when shiitake mycelia cover the top of the bags in summer. This is because summer creates a higher risk of contamination. The farm A produces about 4,000 bags per cycle, which takes 3 days, from September to February (more or less winter), and about 1,000 bags per cycle from March to August (summer) (Figs. 13).



Each member incubates the delivered shiitake bags for spawn run and produces shiitake on his or her own farm. They send their harvested shiitake to the bag supplier. The farm A collects about 120kg per day in winter and about 50kg per day in summer. This amounts to 3.6 tons per month in winter and 1.5 tons per month in summer. The collected shiitake is trimmed, graded, and packed, and then delivered to the big markets in Chiangmai, Lampang, and Bangkok (Figs. 14). The

price of shiitake fluctuates, and at one time the retail price of shiitake was as low as THB100 (USD2.60) per kg due to the presence of quantities imported shiitake from China. In general, shiitake from the farm A is sold at THB100-120 (USD2.60-3.12) per kg to wholesalers in the nearby provinces.



**Figure 14.** Postharvest at bag supplier's place **A:** Trimming and grading collected shiitake **B:** Shiitake packing

## Cost and benefit

### For farm A (shiitake bag supplier)

**Table 2.** Cost for one bag production

Item	Cost in THB
Sawdust	1.00
Supplement	0.5
Plastic neck	0.25
Plastic bag*	0.35
Labor for filling and packing**	0.50
Depreciation cost of equipments	0.50
Transportation	0.40
Others***	0.50
Total	4.00 (USD0.10)

\* Polyethylene plastic bag 1kg cost THB75 (USD1.935) has approximate 200 bags

\*\* One man day labor cost THB140, can fills and packs the bag 400 bags (skilled person) and 200-300 bags (non skilled)

\*\*\* Rubber band, spawn, fuel for sterilization water, and electrical power

It costs THB4 (USD0.10) for the farm A to produce an inoculated shiitake bag to be delivered to its members. This cost includes substrate materials, plastic bags and necks, labor, depreciation cost, transportation, and other costs (Table 2).

One cycle of bag production takes 3 days: one day for sawdust preparation and filling bags, the second day for sterilization and cooling, the last day for inoculation. This process can be repeated ten times a month. During a winter of 6 months, 4,000 bags are produced by the three day long process. The contamination rate is 10% in winter, so 400 contaminated bags are removed before the rest are delivered to member farms. In addition, some bags are broken during delivery and some bags are contaminated in the member farms and the farm A doesn't charge for these bags. This loss reaches 10% of the delivered bags (360 bags), so it should be calculated that farm A delivers 3,240 bags in one cycle (3 days) and 32,400 bags a month. Therefore, 194,400 bags are sold to member farms over the course of the winter.

Only 1,000 bags are produced per cycle in summer. The contamination rate reaches up to 15% (150 bags) in summer, but additional loss during and after delivery is only 5% of the delivered bags (42.5 bags). It can be calculated that 807.5 bags are delivered by one operation and 8,075 bags a month. Therefore, 48,450 bags are sold to member farms for the whole summer. As a result, the farm A delivers 242,850 bags in the course of one year (Table 3).

**Table 3.** Volume of shiitake bag delivery to member farms per year

	Volume of production per operation (3days)	Volume of production per year	Unusable bags	Sold bags
Summer (6 months)	1,000 bags	60,000 bags	11,550 bags	48,450 bags
Winter (6 months)	4,000 bags	240,000 bags	45,600 bags	194,400 bags
Total		300,000 bags	57,150 bags	242,850 bags

The bags are sold to the members for THB5 each, so the net profit from selling a bag is THB1 because production cost of a bag is THB4 (Table 2). Therefore, the farm A makes a net profit of THB242,850 (USD6,314.3) by selling 242,850 bags per year.

Upon receiving the shiitake, the farm A pays to the member farms THB70 (USD1.82) per kg. A shiitake bag produces average 120g of shiitake, so the sold 242,850 bags in member farms produce 29,142kg per year. The farm A pays THB2,039,940 (USD53,040) to member farms in a year. The sale price of collected shiitake to markets varies according to quality. Shiitake is graded into four grades and the price varies from THB60 to 120 (USD1.56-3.12) according to the grades. When calculated by proportion and price per kg of each grade, the farm A earns THB2,914,200 (USD75,772.2) per year by supplying shiitake to markets (Table 4).

**Table 4.** The value of shiitake sale to market per year

Grade	Diameter (cm)	Proportion (%)	Yearly production (kg)	Price per kg in THB	Yearly value of sale in THB
A	> 3.5	20	5,828.4	120	699,408
B	2.5-3.4	40	11,656.8	110	1,282,248
C	1.0-2.5	20	5,828.4	100	582,840
D	< 1.0	20	5,828.4	60	349,704
Total		100	29,142		2,914,200 (USD75,772.2)

Transportation costs are THB5 for 1kg shiitake, so the farm A pays THB145,710 (USD3,788.6) per year as the transportation cost. The net profit of farm A from supplying shiitake to markets is THB728,550 (USD18,943.1). In conclusion, the net profit of the farm A from supplying both shiitake bags to member farms and selling shiitake to the markets reaches THB971,400 (USD25,257.4) per year (Table 5).

**Table 5.** Cost and benefits of shiitake bag supplier, farm A

<p><b>1. From shiitake bag supply to member farms</b></p> <ul style="list-style-type: none"> <li>• Income from supplying a bag: THB5</li> <li>• Cost for producing a bag: THB4</li> <li>• Profit from supplying a bag: THB1</li> <li>• Net profit of selling bags for a year: THB1 × 242,850 bags = THB242,850 (USD6,314.1)</li> </ul>
<p><b>2. From shiitake supply to markets</b></p> <ul style="list-style-type: none"> <li>• Total value of sale: THB2,914,200 (USD75,772.2)</li> <li>• Transportation costs: THB5 × 29,142kg = THB145,710 (USD3,788.6)</li> <li>• Farmer payments: THB70 × 29,142kg = THB2,039,940 (USD53,041)</li> <li>• Net profit = Total value of sale - Transportation costs - Farmer payments = THB2,914,200 - THB145,710 - THB2,039,940 = THB728,550 (USD18,943)</li> </ul>
<p><b>3. Total Net Profit</b></p> <p>net profit of bag supply + net profit of shiitake sale = THB242,850 + THB728,550 = THB971,400 (USD25,257.4)</p>

### For the members farms

The member farms buy shiitake bags from the farm A at THB5 per bag. The amount of delivered bags varies from 5,000 bags to 10,000 bags per crop depending on the available capital of each farm. If a member farm purchases 10,000 bags per crop, it pays THB50,000 (USD1,300) per crop. The construction cost for a growing house which can contain 10,000 bags is about THB20,000 (USD520) and the house will last for 3-4 years. Most farms cultivate two crops a year though some in highlands cultivate three crops. Therefore, the house depreciation cost is about THB3,333 (USD86.66) per crop. The labor costs for bag management and harvest reaches THB12,000 (USD312) for a crop and other expenses such as water, electricity, and so on are THB300 (USD7.8). Therefore, the total production cost is THB65,633 (USD1,706.53) for a crop (Table 6).

A shiitake bag produces average 120g, so a delivery of 10,000 bags produces 1,200kg for a crop. A member farm is paid by THB70 for 1kg shiitake, and it can earn THB84,000 (USD2,184) for a crop. The net profit of a member farm is THB18,367 (USD477.56) for a crop (Table 7). However, most farms pay their own labor without employing workers. In that case, the net profit per crop reaches THB30,367 (USD789.57). In conclusion, the yearly net profit of a member farm is at least THB36,734 (USD955.12) and at most THB60,734 (USD1,579.15) for cultivating two crops (Table 7) per year.

**Table 6.** Production cost for a member farm per crop

Item	Unit price in THB	Number of units	Cost in THB
Shiitake bags	5	10,000 bags	50,000
A growing house containing 10,000 bags	20,000	it lasts for 3 years and two crops are cultivation a year	3,333
Labor cost	12,000		12,000
Others	300		300
Total			65,633 (USD1,706.53)

**Table 7.** Cost and benefit of a member farm

<p><b>1. Production cost per crop</b> Including labor cost: THB65,633 (USD1,706.53) Excluding labor cost: THB53,633 (USD1,394.51)</p>
<p><b>2. Value of shiitake sale per crop</b> Volume of shiitake sale: 120g × 10,000 bag = 1,200kg Value of shiitake sale: 1,200kg × THB70 = THB84,000 (USD2,184)</p>
<p><b>3. Net profit per crop</b> when workers are employed, Net profit = Value of sale - production cost (including labor cost) = THB84,000 - THB65,633 = THB18,367 (USD477.56) when family labor is used, Net profit = Value of sale - production cost (excluding labor cost) = THB84,000 - THB53,633 = THB30,367 (USD789.57)</p>
<p><b>4. Net profit per year</b> Minimum: THB36,734 (USD955.12) - when workers are employed Maximum: THB60,734 (USD1,579.18) - when family labor is used</p>

According to Office of the National Economic and Social Development Board in Thailand, the average income per capita in rural areas is THB916 (USD23.82) per month and THB10,992 (USD285.80) per year. When it is assumed that a family has 4 members, the average income per family in rural area is THB43,968 (USD1,143.21) per year. The income source for shiitake growers is the value of shiitake sale to bag supplier and their yearly income reaches THB168,000 (USD4,368) for cultivation two crops. Therefore, it can be said that a shiitake cooperative member farm makes more money than an average rural family.

## Conclusion

Shiitake can be easily cultivated in northern Thailand with relatively low costs and low technology. However, a high yield and high quality requires that farmers have more experience in shiitake cultivation. Communities in the northern region of Thailand can capitalize on their relatively cheap home labor by encouraging more shiitake production. The additional income from shiitake growing can further improve a farmer's standard of living. Clearly, the establishment of a properly organized mushroom growing industry is a vital component of the rural development programs in Thailand.

## Acknowledgement

Special acknowledgement for translation to Dr. Uraporn Sardud, Department of biology, Chiangmai University, Dr. Morakot Sukchotiratana, Department of Biology, Chiangmai University, and Dr. Wong Wee-Chong, food safety scientist & lead auditor, Malaysia.

## REFERENCES

- Panuthut, C. 2001. Information for decision of mushroom cultivation. In: *Thai Mushroom*. Bangkok, Thailand: Newthumma. pp. 1-12.
- Singh, R.B. 1988. Statement by Dr. R.B. Singh FAO Regional Plant Production and Protection Officer. In: Food and Agriculture Organization and Department of Agriculture, Kasetsart University, eds: *Development of Button Mushroom Cultivation amongst Small Scale Growers in Northern Thailand*. Bangkok, Thailand: Regional office for Asia and the Pacific (RAPA) Food and Agriculture Organization of the United Nations. pp. 3-4.

## Part I Shiitake

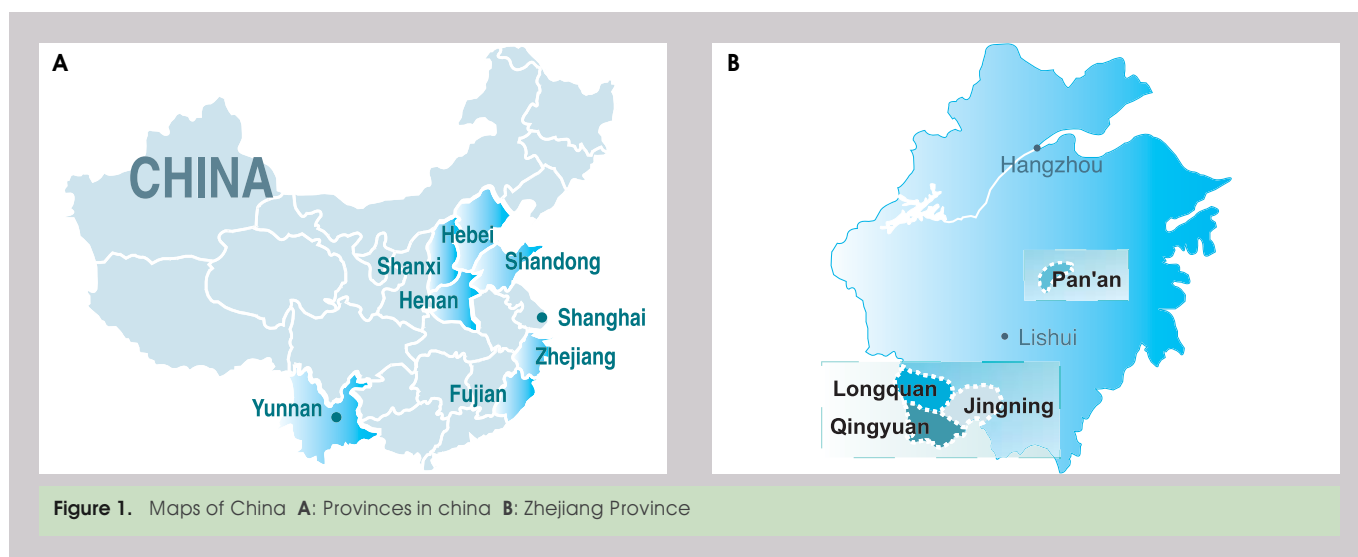
## Chapter 4

Shiitake Bag Cultivation

## SHIITAKE BAG CULTIVATION IN CHINA

Leifa Fan<sup>1</sup>, Huijuan Pan<sup>1</sup>, Yingmei Wu<sup>2</sup> and Kyung Wha Choi (Ivy)<sup>3</sup><sup>1</sup>Horticultural Institute, Zhejiang Academy of Agricultural Sciences, Hangzhou, 310021, P.R. China \*(fanleifa@yahoo.com.cn)<sup>2</sup>Zhejiang Qingyuan Nature Co., Ltd., P. R. China<sup>3</sup>MushWorld, Korea

Shiitake has been cultivated for over 1,000 years in China. The first written record of shiitake log cultivation comes from the Sung Dynasty (960-1127 A.D.), but other documents recorded that shiitake had been consumed in 199 A.D. (Wang, 1993). Among many mushroom varieties, shiitake is the mushroom with the largest volume of production in China, accounting for 2 million tons per year (Gu, 2003), of which Zhejiang and Fujian produce half (Chang and chen, 2003). Shiitake grows naturally in a sub-tropical zone with an average annual temperature of 15.2-17.7 °C and average annual rainfall of over 1,000mm. The mountainous area of Qingyuan in Zhejiang province is regarded as the location of the first shiitake cultivation (Fig. 1B). The regions centered around the Qingyuan area produce half a million tons of fresh shiitake by the bag cultivation method. Shiitake producing areas have recently been appearing in other areas of northern China such as Henan, Shanxi, and Shandong, principally because of the lower price of substrates and higher profits than those in the south shiitake production region (Fig. 1A). Many shiitake farmers from Zhejiang and Fujian are moving to the suburbs of metropolitan cities in northern China and they are bringing with them money and growing knowledge.



### Development of Shiitake Bag Cultivation in China

The grower controlled parameters of shiitake cultivation include nutrition and environmental factors such as temperature, humidity, air, and light. Social conditions such as market stimulation programs and technical and financial support for farmers are as important as environmental conditions, especially those living in the remote and mountainous villages. The Chinese history of shiitake cultivation provides a very good example of the importance of social conditions.

### Social conditions for shiitake cultivation: Zhejiang model

The demand for shiitake products is an important variable affected by social conditions. The Chinese shiitake industry was first developed to produce exportable materials. The shiitake enterprise started at the Zhejiang Academy of Agricultural Sciences (ZAAS) was the first shiitake export business and regularly sent fresh shiitake to Japan in the early 1980's. Initially, the suburbs of Hangzhou such as Xiaoshan, Fuyang and Lin'an were selected as shiitake production areas. Cultivation techniques were taught to farmers through training courses, and a standard shiitake production model was developed. As the suburbs of Hangzhou became more industrialized, however, shiitake production was transferred to the more rural regions. However, the farmers living in the remote and mountainous villages lacked both funds and cultivation knowledge. After opening to the outside in the 1980's, the Chinese government was seeking poverty alleviation methods that would assist the rural people in mountainous regions. Shiitake cultivation was determined to be a potentially effective means of poverty alleviation, due to low initial costs, high possible profits and relatively quick returns.

For these new programs the poor counties selected for the shiitake cultivation included Pan'an, Qingyuan, Longquan, and Jingning (Fig. 1B). Although shiitake had been traditionally cultivated in Qingyuan, the main method was log cultivation and the production was on a small scale. Thus, financial aid was provided to the farmers as the form of training program package. The government also supported shiitake cultivation here by establishing local markets that made trade more convenient and improved transportation. Initially, the mushroom researchers of ZAAS participated in training and planning, and then the specialists of Shanghai and Fujian joined and added their efforts in supporting the new shiitake production regions.

Increasing numbers of large export companies were founded, and competition increased. Some of these companies financed the farmers and others paid a good price to farmers, both of which increased shiitake production significantly. As a result of the new production, prices lowered to a reasonable level and local shiitake consumption rose. Knowledge of the nutritional and medicinal value of shiitake also spread by word of mouth. All these factors contributed toward creating domestic market with huge potential. Today, about 80% of the shiitake crop is sold in domestic markets.

Shiitake cultivation has become a model among poverty alleviation programs for rural people. Other provinces of China are now adopting and developing the model of Zhejiang, adjusting slightly depending on the local resources and environmental conditions. In some cases farmers have moved and brought knowledge of the cultivation techniques to other regions and in other cases farmers from distant areas have move to Zhejiang to learn about shiitake bag cultivation. Market demand, financial assistance, and technical training and exchange are the key factors in this large increase of shiitake production.

### History of shiitake bag cultivation in China

Shiitake sawdust cultivation was developed in China in the 1960's using glass bottles as containers. Later, in the 1980's, shiitake was produced on molded bricks of sawdust (Fig. 2). Although effective, this method was very laborious. The sawdust mixed with supplements was placed in the bottles and then sterilized in an autoclave. After inoculation, the substrate in the bottles was incubated for 40-50 days. Upon full colonization, the substrate was removed from the bottle and then molded into a square wood frame of 30 × 20 × 5cm. Then the substrate was covered with plastic film and aerated for one week. Shiitake mycelium secreted brown water and the surface of the substrate was browned. Then the film was removed and fruiting was induced.



**Figure 2.** Shiitake fructified in the molded bricks of sawdust

Research on shiitake cultivation using plastic bag was inspired by the successful cultivation of *Tremella* in plastic bags in the late 1980's. This technique was quickly extended across the country and annual national shiitake production rose as a result. With bag culture the production cycle was shortened to 90-120 days' spawn run and 4-5 months' harvest. The biological efficiency of bag production is 50-60%.

It has been reported that shiitake production in China increased 135 fold between 1983 and 2003 (Chang and Chen, 2003). The volume of shiitake production in China was perhaps 90% of world shiitake production in 2003 (Gu, 2003). It is estimated that 95% of the domestic production of shiitake is by bag cultivation with sawdust substrate (Gang, 2001). The percentage of the most desirable flower shiitake with white cracks on the caps is about 20% of domestic production (Yu, 2003).

## Practices for Shiitake Bag Cultivation in China

### Crop cycle and strains

There are many shiitake strains cultivated in China. Generally, shiitake can be cultivated for the whole year even in natural conditions if good protection from sunlight is provided and if high temperature strains are used in summer in the mountainous regions. The inoculation time varies according to the strains and regions. Usually one crop of shiitake is cultivated per year. Shiitake is mainly harvested in autumn and spring with a lesser amount harvested in winter. The production cycles and strains appropriate for each cycle are listed in Table 1. In the common 'Spring to Summer' cycle, high temperature strains are inoculated for summer fruiting.

**Table 1.** Production cycle and strains

Production cycle	Inoculation time	Spawn run period	Fructification time	Strains
Spring to fall and winter	February - April	More than 120 days	Fall and winter	241-4*, 9015, 939, Q20, 135*
Spring to summer	February -April	90-120 days	Summer fruiting	W-1*, Cr04, G47, 8001
Fall to next spring	Fall	90 days	Winter and spring	L82-2, 865, 9612, 33, 62, 66, 26, Cr02*

\* Popularly used strain in China

### Materials for substrate

Required nutrition for shiitake cultivation includes carbohydrates and nitrogen and a small quantity of mineral and vitamins. Theoretically, any agro-industrial organic materials which can provide the essential nutrition can be used as a substrate material for shiitake cultivation. This includes crop stalks, sawdust, sugarcane bagasse, cottonseed hulls, corncobs, and beanstalks. Some grasses<sup>1</sup> are also used for shiitake cultivation, including *Dicranopteris dicnotoma* Bernh, *Neyraudia reynaudiana* Keng, *Saccharum arundinaceum* Retz, *Phragmites communis* Trin, *Miscanthus floridulus*, *Themeda gigantean* var., *Pennisetum ourpureum* Schumach, and *P. sinese* Roxb. All substrate materials should be ground prior to use lest spiky substances poke holes in the plastic bag. The main substrate requires supplementing with a rich nitrogen source such as rice bran, wheat bran, bean cake, rape cake, peanut cake, urea, or ammonium sulphate. These nitrogen sources are usually added at a rate of 10-20%. Minerals are also added such as gypsum, calcium carbonate, and calcium superphosphate.



**Figure 3.** Making sawdust with collected branches **A:** Collected branches stored in the corner of a farmer's house **B:** Sawdust making machine

Hardwood sawdust is the single best substrate material for the production of the highest quality shiitake. Many shiitake farmers in rural areas collect branches and twigs in the mountains in order to make sawdust by themselves (Figs. 3). The typical formula for shiitake cultivation in China is sawdust 78%, wheat bran 20%, gypsum 1%, and brown sugar 1%. These days

<sup>1</sup> For more information, see ALTERNATIVE SUBSTRATE: GRASS in Chapter 4.

cottonseed hulls are also widely used in shiitake bag cultivation. That typical formulation is cottonseed hull 50%, sawdust 28%, wheat bran 20%, gypsum 1%, and sugar 1%. These formulations have been developed by both experienced shiitake farmers and research organizations. The formulations can be changed each year according to the regional prices of the materials. For example, if cottonseed hull prices are high in a certain year, growers are likely to use less cottonseed hulls in order to reduce their production costs. Table 2 shows a substrate formulation for shiitake cultivation that has been adopted by many Chinese growers.

**Table 2.** Formulation of shiitake cultivation in China

Formulation	Main substance	Supplements
1	Hardwood sawdust 78%	Wheat or rice bran 20%, Red sugar 1%, Gypsum 1%
2	Hardwood sawdust 77%	Wheat or rice bran 20%, Red sugar 1%, Gypsum 1%, Calcium superphosphate 1%
3	Cottonseed hull 50%, Hardwood sawdust 28%	Wheat or rice bran 20%, Red sugar 1%, Gypsum 1%
4	Sugarcane baggasse 39%, Hardwood sawdust 39%	Wheat or rice bran 20%, Red sugar 1%, Gypsum 1%
5	Sugarcane baggasse 78%	Wheat or rice bran 20%, Red sugar 1%, Gypsum 1%

Note: The principal difference is the main substances, dependent on the local resources.

It is difficult to determine which formulation achieves higher productivity, and in most cases, growers choose the materials that are cheap and easy to obtain in their area.

### Plastic bag and filling

The size of the plastic bags used differs depending on the mushroom species. In most cases, polyethylene or polypropylene bags that are 55-60cm long and 15-16cm wide are used for shiitake cultivation. The substrate materials are evenly mixed and clean water is added at a ratio of 1:1.2 (substrate/water) to achieve a water content of about 55%. Growers are advised to pile the substrate mixtures for 1-2 hours while the materials fully absorb the water. The mixture can be packed into the plastic bags either by hand or with a bagging machine (Fig. 4A). The bags are compacted during filling if a bagging machine is used. The ends of the filled bags are tied with string (Fig. 4B). Filled bags weigh about 2kg. The bags are arranged for sterilization. To stop the piles from collapsing growers tie the piles with string (Fig. 4C). When all the bags are ready, the pile is covered with a plastic sheet and steam is injected underneath the plastic cover.



**Figure 4.** Filling bags **A:** Filling with bagging machine **B:** Tying with string **C:** Bag arrangement with strings for sterilization

### Sterilization

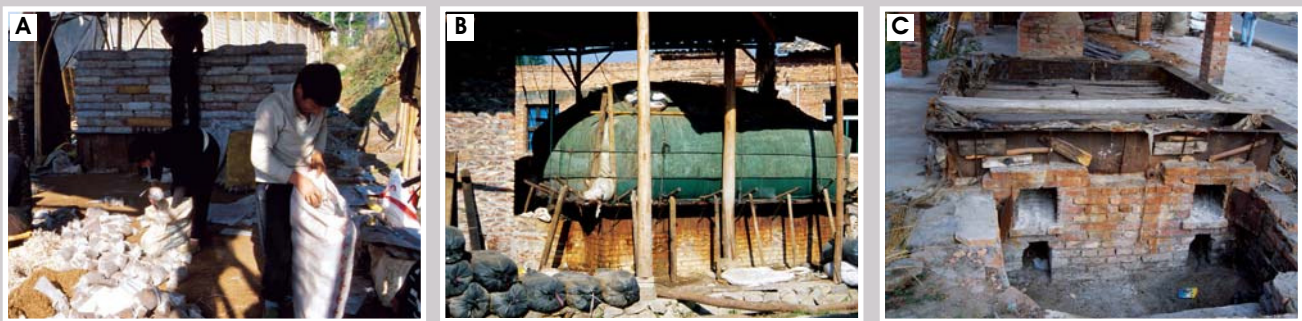
The bags are sterilized to remove the competitive microbes. Several different methods are used for sterilization. Injecting steam into the piled bags under plastic cover is a popular technique. The bags are sterilized at 100 °C for 8-10 hours. The temperature inside the plastic cover is checked, not the substrate temperature. It usually takes more than 10 hours to raise the air temperature inside plastic cover up to 100 °C, and then bags are sterilized for an additional 8-10 hours. Figure 4C shows a boiler used to inject steam under a plastic cover.

Another common type of sterilizer in rural areas is a kiln. The filled bags are put into sacks for safe arrangement and the sacks are arranged in the kiln (Fig. 5A). The piled sacks are covered with cloth and tied, and then a fire is used to boil water beneath bags and the bags are then sterilized by the steam (Fig. 5B). Figure 5C shows the structure of fire holes and base of a kiln. Water is poured into the frame above the fire holes and the boiled water sterilizes the piled bags.

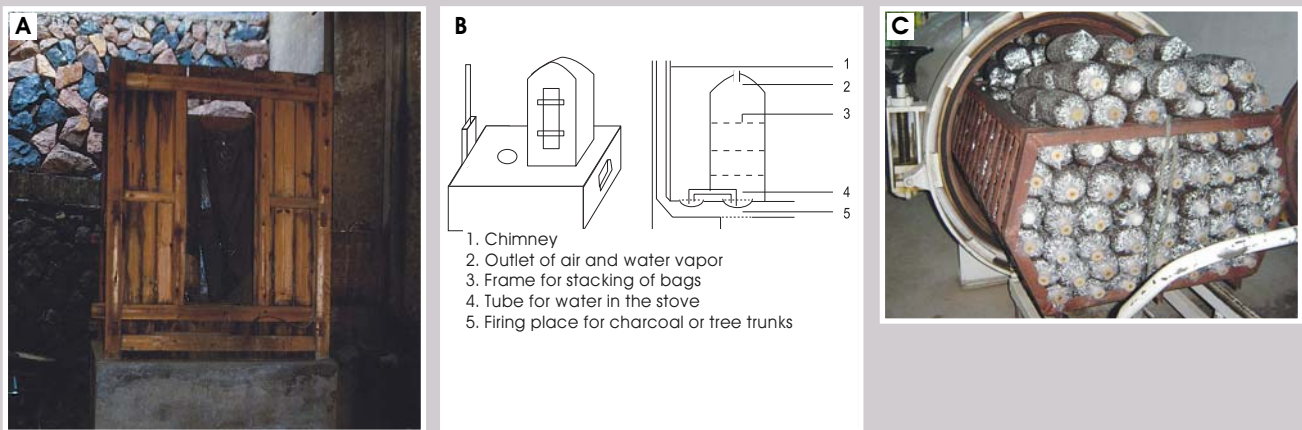
A steaming room is another method used for sterilization (Fig. 6A). In this system, the bags are stacked in layers in the steaming room and sterilized at 97°C for 8-10 hours. This method uses stoves fired by charcoal or tree trunks. Figure 6B shows the structure of a steaming room very well. With this method, the substrate temperature can reach 97°C in one hour and this temperature should be maintained for 8 hours.

In some regions, the bags are sterilized in an autoclave at 100°C for 8 hours (Fig. 6C). On the following day, the bags are taken out when the temperature inside the autoclave drops to 60°C.

The bags are taken to the inoculation room and cooled to room temperature before inoculation. The inoculation room should be disinfected before the transfer of bags to prevent contamination during cooling and inoculation.



**Figure 5.** Sterilization kiln **A:** Arrangement of sacks with bags **B:** Sterilization with kiln **C:** The structure of kiln



**Figure 6.** Steaming room and autoclave **A and B:** Steaming room and its structure **C:** Autoclave

## Inoculation

Spawn is generally purchased from spawn production companies. Some farmers do produce their own spawn if they have mastered the techniques. Mother cultures can be obtained from research units. A farmer needs just one portable autoclave (50 liters) and an inoculation box equipped with a UV light in order to produce their own spawn. After some trials, they can get good results at a less than 5% contamination rate.

The bags are inoculated once they have cooled to below 25°C inside the inoculation box (Fig. 7A). An inoculation box is relatively inexpensive to produce and is effective in preventing sterilized bags from coming in contact with outside air that contains many microorganisms. Both sides of the bags are punched with 3 holes, each 1.5cm in diameter and 2cm in depth,

and then sawdust spawn is inserted into the holes by hands. Plugs and liquid spawn are also used in some regions, but these spawn types are not very popular. The holes are sealed with adhesive tape, or the bags are put inside other bigger plastic bags to prevent contamination in the early stage of incubation (Fig. 7C). The thin outer bags are peeled off about 10 days later once mycelial growth appears around the inoculated parts. The ratio of spawn to substrate is 2-3% in general and the contamination rate is under the 5%, though this all varies depending on the individual farmers.



**Figure 7.** Inoculation **A:** Inoculation within inoculation box **B:** View inside the inoculation box **C:** Inoculated bags covered with thin bags

### Management for mycelial growth

After inoculation, the bags are carried to the incubation room and stacked into pile (Fig. 8A). The duration of this phase depends upon the strains inoculated and environmental conditions. In general spawn run requires 90-120 days. It is recommended that growers re-stack the bags periodically in order to provide an equal amount of accumulated temperature and humidity for each bag. Changing the layers occasionally also prevents substrate temperature from becoming too high. The bags are also turned at regular intervals in order to provide a similar micro-environment to both sides of each bag.

Shiitake mycelia are aerobic, so they require oxygen for their growth. Because the plastic bags do not have any filter for air exchange, perforation is required. As the mycelia grow and cover more parts of bags, growers perforate the bags to provide more oxygen. Perforation is done around the edges of mycelial growth and will cover the whole bags by the time the bags are fully colonized (Fig. 8B).

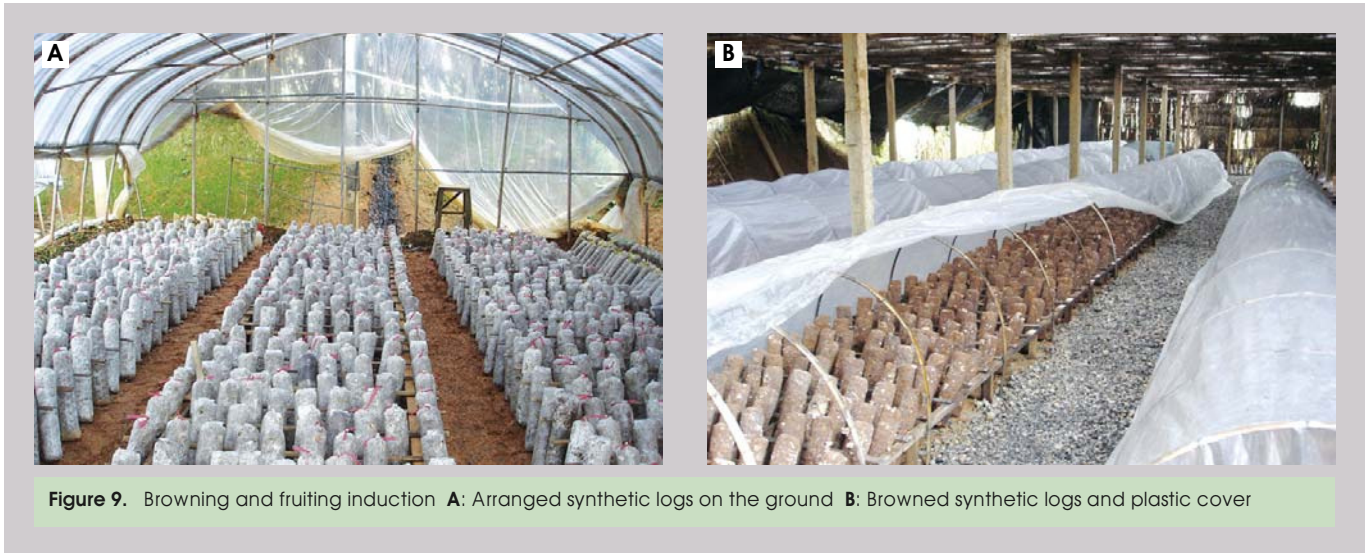


**Figure 8.** Spawn run **A:** Stacked bags during spawn run **B:** Perforation for oxygen supply

The mycelia growth is basically completed when the bag surface is grown through with white mycelia. The bags are transferred to a growing house when there are some red spots or small warts on the surface of the bag. In some cases, the incubation room can be used as the fructification room, but this space does need good protection from sunlight during the summer.

### Primordia formation and fruiting

When the substrate bags are fully colonized by shiitake mycelia, they are moved into a growing house. In some cases, the plastic coverings are removed from bags and the substrates are placed on the ground of the growing house, leaned against a frame of wooden sticks or iron wires (Fig. 9A). Next, the substrates will go through a browning process. During browning, the temperature is kept at 20-25 °C for 3-5 days. When the mycelia on the substrate surface become dark white in color, the ventilation should be gradually increased. When the surface color of the substrates turns from light brown to dark brown and yellow water drops appear, it is time to spray water to induce primordia formation. The color change directly affects the yield of shiitake. A shiny brown color is usually an indicator of high quality and high productivity. Some growers peel off the plastic bags after browning. Coverage of a thin plastic film over the spawned blocks helps maintain appropriate humidity (Fig. 9B).



When the mycelial surface turns brown, temperature and humidity are controlled by watering the substrates and lifting up the plastic cover at night for 5-7 days. The change of temperature, humidity and light can stimulate primordia formation. About one week later, the primordia appear. No water is needed at this time, but humidity is maintained and minimal ventilation is used because primordia are very sensitive. After the fruiting bodies grow to 2cm in diameter, direct watering is possible again. During the development of fruiting bodies, the lower the temperature, the slower the shiitake develops and thicker caps and shorter stems produce a high quality shiitake mushroom.



In other cases, the substrate bags are placed on the shelves in a growing house without removing the plastic coverings, and they are kept on until the harvest is finished (Fig. 10A). The plastic covering helps the substrate keep more moisture, so it is more likely to produce a higher quality of shiitake (Fig. 10B). When primordia form, growers need to cut the plastic at all the places where the primordia have formed, and this is a very time consuming and laborious process.

### Flower shiitake cultivation

Flower shiitake with white cracks on its cap is considered the best quality of shiitake in many countries of Asia (Figs. 11). Cracking of mushroom cap occurs spontaneously in nature during cold and dry winter months. The flower pattern is not a characteristic of a particular genotype or genetically inherent trait, but rather a morphological flower-like cracking pattern on the upper surface of the cap. This white cracking pattern is produced by the different growth rates between the surface and the inner section of the cap due to drastic diurnal fluctuations of temperature and humidity. In most cases, flower shiitake is now produced on shelf systems with plastic coverings on the substrate. Flower shiitake production requires high humidity and temperature in daytime and lower humidity and temperature during nighttime. Sometimes, growers warm the growing houses with hot water steaming during the day and lift up the overhead plastic covering during the night to lower humidity and temperature. The techniques employed in an attempt to produce flower shiitake are applied when the caps of the fruiting body reach 2-3cm in diameter. Using the flower producing techniques too early may result in the death of the fruiting bodies because of their delicacy during the early stage of fruiting. On the other hand, too late an application may produce no results. When growers attempt flower producing, the number of fruiting bodies is reduced to fewer than 5 in one bag for each flush. The price of dried shiitake varies according to the quality, and the wholesale price of dried flower shiitake may be as high as USD10-20 per kg, while the price for regular air dried shiitake is USD5 per kg, and the low quality shiitake price is only USD3 per kg.

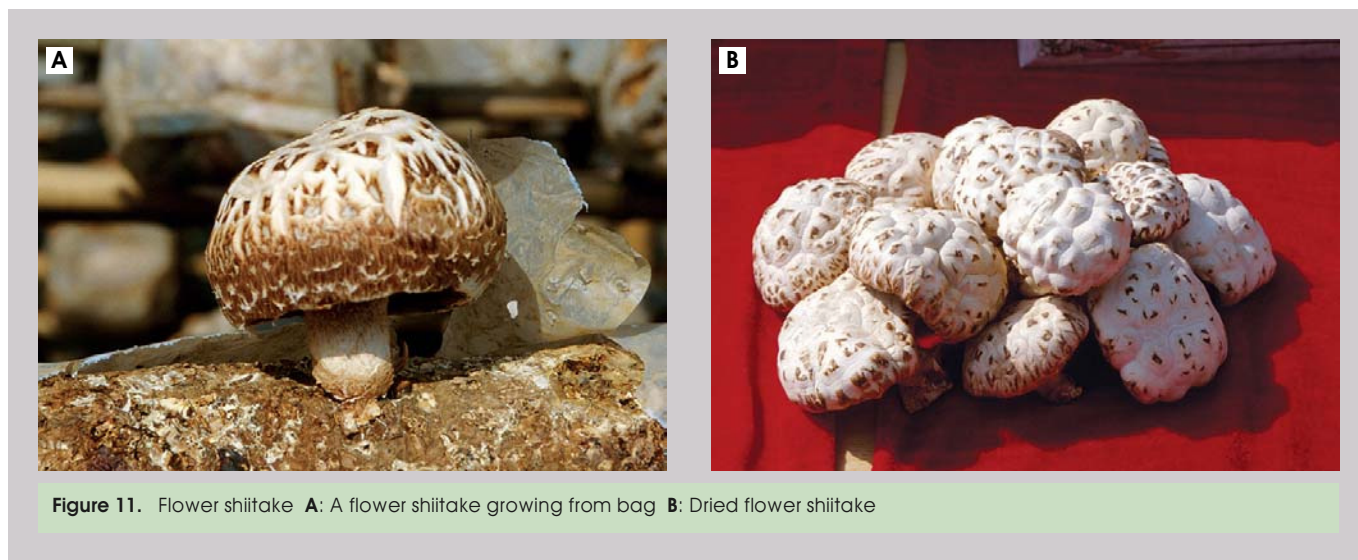


Figure 11. Flower shiitake A: A flower shiitake growing from bag B: Dried flower shiitake

### Management for fruiting in each season

In China, one crop of shiitake is usually cultivated per year with family labor, and growing is mostly dependent on natural conditions. Therefore, it is highly recommended that Chinese growers inoculate with high temperature strains in order to produce fruit in summer, but fruiting of high temperature strains is most possible in mountainous regions during the hot summers. For summer fruiting, it is recommended to build the growing houses under trees and spray water 2-3 times a day in order to lower the temperature and increase humidity. For autumn fruiting, it is crucial to maintain the humidity at 90% by spraying water several times a day. Much attention should be paid to maintaining optimal temperatures during early fall when the ambient temperatures are high and during early winter when the outside temperatures are low. Usually, 4-5 flushes are harvested in fall. Winter is a period of dormancy, with very little harvest, so the substrate should be managed in such a way that it may recover vitality and prepare nutrients for the next fruiting in spring. It is essential to reduce air exchange and maintain the temperature and humidity of growing house in winter. In the spring, 2-4 flushes can be harvested if the management is proper. The substrates are immersed in water for 1-2 days so as to absorb enough water before fruiting induction. In general, 6-8 flushes are harvested for 10 months. Chinese growers harvest 0.5-0.6kg of shiitake from

substrate bags of 2kg. The dry weight of the substrate is about 1kg, so biological efficiency is about 50-60%.

### Harvest and marketing

Shiitake mushrooms are harvested when the edges of caps are still curled in and before the caps are open. Care is required not to harm the substrate during harvest and not to damage harvested shiitake during handling and transportation. Growers might not want to harvest shiitake shortly after watering or raining, as shiitake quality will be lower due to more water content and the shelf life will be shorter. After harvest, it is recommended to deliver shiitake to markets as soon as trimming and grading are completed (Fig. 12A). If shiitake cannot be delivered to the market quickly, cold storage in refrigerator is recommended, but this type of facility is quite costly to growers in rural areas. Therefore, shiitake is often dried with hot air for longer preservation. There are specific companies that dry shiitake, but some growers have drying equipment in their own farms (Figs. 12B and C).



**Figure 12.** Trimming and drying shiitake **A:** Trimming and grading shiitake before market delivery **B and C:** Drying equipment using hot air and its fire place

Fresh shiitake is delivered to markets and sold to buyers or wholesalers (Figs. 13A, B and C). Fresh shiitake is exported to Japan, but most of the shiitake in domestic markets is dried. Therefore, most shiitake production bases sell dried shiitake. Qingyuan county is a good example, as it has very a big market that deals only in dried shiitake (Figs. 14).



**Figure 13.** Street vendors for fresh shiitake in rural area of Zhejiang **A:** Growers and wholesalers in street market **B:** Bargaining **C:** High quality fresh shiitake



**Figure 14.** Dried shiitake market in Qingyuan county **A** and **B**: A lot of people and dried shiitake in the market **C**: High quality dried shiitake **D**: Sieve grading dried shiitake according to cap size **E**: Stems are also dried and sold

### Cost and Benefits of Shiitake Bag Cultivation in China

The basic investment required for shiitake bag cultivation by a family owned farm is shown in Table 3. A house (100m<sup>2</sup>) for inoculation and spawn run costs USD1,500. The equipment costs USD280, which includes a bagging machine (USD80), a sterilizer with a steam generator (stove) (USD150), and an inoculation box equipped with a UV lamp (USD50). All of this equipment and house usually lasts for at least 10 years. A growing house (200m<sup>2</sup>) made with bamboo and plastic film costs

**Table 3.** Cost and benefit of shiitake cultivation in China for one year in USD

Cost	Item	Cost	Depreciation cost
	House for inoculation and spawn run	1,500 (10 years)	150
Equipments*	280 (10 years)	28	
Shiitake house	500 (3 years)	167	
Substrate and bags	800	800	
Total production cost		1,145	
Benefit	Volume of production	Price per kg	Income
	5,000-6,000 kg fresh shiitake	0.4	2,000-2,400
Net profit	Total income – Total production cost	minimum: USD855, maximum: USD1,255	

\* Equipments include bagging machine (USD80), sterilizer with a steam generator (stove) (USD150), an inoculation box equipped with a UV lamp (USD50).

USD500, and last only for 3 years. If a farm makes substrate materials of 10,000kg dry weight every year, which can produce about 11,000 bags of 2kg, the cost of the substrate materials reaches USD800. The total production cost is USD1,145, figuring substrate material costs and the depreciation of equipment and houses (Table 3). Labor costs are not calculated because only family labor is utilized.

Substrate materials of 10,000kg dry weight can produce about 5,000-6,000kg fresh shiitake, which corresponds to 500-600kg of dried shiitake. The fresh shiitake price per kg varies with seasons and quality, but the average price is USD0.3-0.5 per kg. The average price of dried shiitake is USD3-5 per kg. If the yearly average price is USD0.4 per kg, a family can earn a minimum of USD2,000 by selling 5,000kg of fresh shiitake, and a maximum of USD2,400 by selling 6,000kg of fresh shiitake. The net profit of a family is a minimum of USD855 and a maximum of USD1,255 per year. Greater profit is possible if a greater amount of flower shiitake is produced. In most cases, shiitake cultivation is an additional income source, as most shiitake growers grow other plants such as rice, corn, sweet potato, and vegetables as their principal occupation.

## REFERENCES

- Chang, S.T. and M.J. Chen. 2003. History, actual situation and prospect of shiitake production. *Edible Fungi* 25(1): 2-4.
- Gang, Q.H. 2001. Shiitake production in western and southern Zhejiang and ecological study. *Zhejiang Forestry Science* 21(4): 71-76.
- Gu, E.X. 2003. Situation of mushroom production and products. *Edible Fungi of China* 22(6): 3-4.
- Wang, N.L. 1993. *Edible Fungi Cyclopedia of China*. Beijing Chinese Agricultural Publishing House.
- Yu, C.B. 2003. Production of flower shiitake in China. *Edible Fungi of China* 22(5): 29-30.

## Part I Shiitake

## Chapter 4

Shiitake Bag Cultivation**FARM DIARY FOR SHIITAKE BAG CULTIVATION**

Chan-Kyu Choi

Han Jung Nong San, 26-4 Go-po, Song-san, Hwa-sung, Kyung-gi, Korea (kumung1@hanmail.net)

Reported by Song Baek Cho, MushWorld, Korea

Translated by Kyung Wha Choi, MushWorld, Korea

**My Personal History as a Shiitake Grower**

**Figure 1.** The author taking care of shiitake bags

I was born in Song-san, a village that is famous for grape production in Korea and my family cultivated grapes. I used to grow grapes, but decided to choose another produce which could provide greater profits. While searching for an appropriate produce, I chanced to attend SIEMSTA (Seoul International Exhibition of Machinery, Science and Technology for Agriculture) in 1998. There I encountered shiitake bags imported from China and these attracted me very much. As one of the traditional products in Korea, shiitake has been considered a relatively luxurious food so its price is quite high if the quality is good. At that time, almost all shiitake in Korea were cultivated from logs because people believed that high quality shiitake could not be obtained from bag cultivation. After pilot trials with some sample bags imported from China, however, I found that the quality of shiitake cultivated from sawdust bags was good and I was convinced

that I could produce high quality shiitake from bag cultivation.

I began to research the possibility of my cultivating shiitake in bag cultivation here in Korea. It was not an easy task because I had very little knowledge concerning shiitake cultivation on either logs or in sawdust, and very little information on shiitake bag cultivation was available in Korea at that time. I started my own shiitake bag cultivation but the results of early days were terrible failures. It is very important to emphasize that I experienced a lot of failures and performed numerous trials before I finally became able to realize a profit from shiitake bag cultivation. The numerous failures taught me what to do and finally I became one of the pioneers of shiitake bag cultivation in Korea.

**Farm diary and my success**

I began to write my farm diary when I first started shiitake cultivation. My wife and I checked the temperature, humidity, bag condition, and fruiting body condition of each growing house every three hour by turns. I also examined and studied what happened to bags and shiitake quality under certain temperatures and humidity as well as under different amounts of watering. Finally, I accumulated enough experience and understanding concerning appropriate temperatures, humidity, ventilation, and watering for each step of shiitake bag cultivation. Actually, I am not writing such a laborious farm diary any more because I established my own cultivation methods which, I think, fit best for the Korean natural environment and market characteristics. However, I am still applying what I learned from my farm diary in striving for better shiitake quality. I recommend that all new growers keep a farm diary because this activity helps you learn about shiitake growing.

I wrote this particular farm diary not for my own reference, but rather to share my experience and knowledge with other

shiitake growers. I have visited various regions in China to see how they cultivate shiitake on sawdust bags, so many parts of my growing methods are modeled after activities I saw in China. I have applied these methods to fit the environment and shiitake market of Korea. A grower may find my methods inappropriate for their own situation, and such differences are natural. We live in countries or regions with different temperatures, humidity, social customs, available equipment, distribution systems, and market demand. I just hope all growers can learn from my experiences and apply this knowledge to their own situations. Good luck to all!

**Why I chose bag cultivation**

Shiitake can be produced throughout the year if cultivated on sawdust bags because the environment is much more controlled than with log cultivation. This method produces a stable income to growers all year round. In addition, bag cultivation enables planned production of shiitake by controlling production cycles, which prevents a fall in the price of shiitake caused by over production. However, absolute control of the environment is sometimes so expensive that shiitake production can be less profitable. Therefore, I am trying to achieve a maximum of efficiency at a minimum of cost by making the utmost use of the natural environment of each season.

The name of my shiitake farm is Han-Jung, which means ‘cold well’ in Korean. I have three growing houses (total 792m<sup>2</sup>), one incubation room (198m<sup>2</sup>), a small cooling room and a spawning room and cold storage (66m<sup>2</sup>) and a work area (132m<sup>2</sup>) with a mixer and a bagging machine. I also have a ribbon mixer, a sterilizer, and a clean bench for inoculation. The full capacity of my growing houses is 9,000 bags at the same time, and I can cultivate 2.5 crops a year. Therefore, I estimate that I can cultivate 22,500 bags per year.

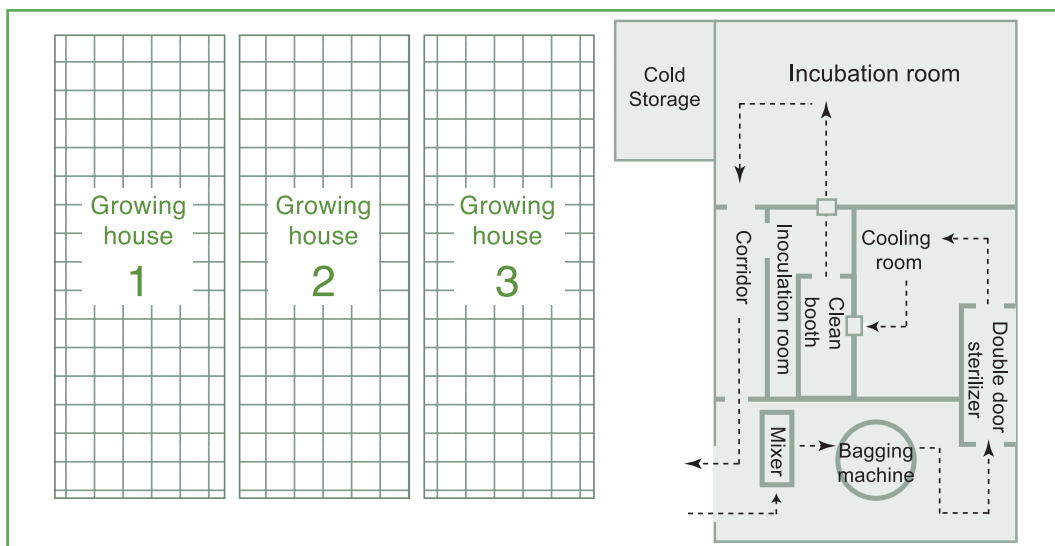


Figure 2. Schematic drawing of Han-Jung (“cold well” in Korean)

**<Shiitake cultivation cycle written in this farm diary>**

Month \ Location	April	May	June	July	August	September	October	November
Incubation room	■	■	■					
Growing house #1			■	■	■	■	■	■
Growing house #2				■	■	■	■	■

Lot #1: Group 1 ■ Group 2 ■  
 Lot #2: ■

## Bag Preparation and Inoculation

April 9, 2004

Temp. : 3.8/20.5 ℃

R.H.: 47.0%

Rainfall : 0mm

Sunny

All the substrate materials have been delivered. In March and April, I prepare bags with formulation for high temperature strains. Though these bags are made in spring, the shiitake will start to fruit 2 months later when the bags are fully incubated by the shiitake mycelia, which will be hot summer. Shiitake strains are classified by its optimum temperature range for fruiting induction (appropriate temperature for spawn run is uniform for every strain), so one should choose a strain suitable for the temperature when it fruits, not when it is inoculated. This can be confusing for beginners.

### Preparation of materials and its formulation

For high temperature strains, I use the substrate formulation as shown in Table 1 while I use a different formulation for the low temperature strain as shown in Table 2.

**Table 1.** Substrate formulation for high temperature strain

Material	Sawdust	Wheat bran	Rice bran	Gypsum	Brown sugar	Lime	Calcium carbonate	Total
Quantity (kg)	700	60	60	7	7	4	6	844
Ratio (%)	83	7.1	7.1	0.8	0.8	0.5	0.7	100

**Table 2.** Substrate formulation for low temperature strain

Material	Sawdust	Wheat bran	Rice bran	Gypsum	Brown sugar	Calcium carbonate	Urea	Potassium carbonate	Total
Quantity (kg)	700	63	63	9.8	9.8	2.1	2.1	1.98	851.78
Ratio (%)	82.2	7.4	7.4	1.2	1.2	0.2	0.2	0.2	100

Supplements such as wheat and rice bran, brown sugar provide nutrients that are lacking in sawdust, but the high nutrients within the supplements are more likely to cause contamination, especially in summer. Therefore, they are less used for the high temperature strain and urea and potassium carbonate are not added. I concluded from my experience that the formulation in Table 1 is so far the best for the high temperature strain because of the minimized contamination rate, though I may change my mind later. The current contamination rate is lower than 1%.

Lime is added only for the high temperature strain. If lime is added, the substrate temperature increases up to 60 ℃ during mixing, so this functions as pasteurization and the contamination risk decreases as a result. Gypsum adjusts the acidity of the substrate. The initial acidity of the substrate is about pH7, but becomes pH3-4 after sterilization. Rice bran is easy to obtain, but also decomposes easily. It has a high nutrient content and thus increases contamination risk. When the time between mixing and sterilization is long, rice bran is more likely to decompose. Therefore, I mix wheat bran with rice bran at the rate of 5:5. It is recommended to use fresh rice bran.



**Figure 3.** Oak sawdust and chip (5:5)

I currently use both oak chip of 3-5mm and sawdust of 2-3mm in diameter at the rate of 5:5 (Fig. 3). But, the porosity is quite high, so I am planning to change the rate to 4:6. The appropriate porosity or solidity of substrate bags can be tested by pressing them with a finger. If the bag recovers soon after pressing, it is appropriately compacted.

The difference caused by sawdust particle size is worthy of explaining. If 3-5mm chips are used for more than 50% of the mix, it takes longer for the shiitake mycelium to penetrate the particles and absorb the nutrients. Though the white mycelia cover the particles, it takes more time to digest and absorb the nutrients inside the particles. 3-5mm chips give a steady and good quality shiitake for up to 10 flushes, while 2-3mm sawdust produces only a very small amount of fruiting bodies after the second or third flush. When 3-5mm chips and 2-3mm sawdust are used half and half, the

first flush could be of low quality, but high quality shiitake will be harvested from the second flush.

April 10, 2004

Temp. : 5.3/21.7 ℃ R.H.: 42.1% Rainfall : 0mm Partly cloudy

Today, I mixed substrate materials and filled 1,200 bags and put them into the sterilizer. They are being sterilized tonight for 6 hours.

### Mixing substrate materials

All the substrate materials are mixed for one and one-half hours. At first, sawdust and wheat bran and rice bran are poured into ribbon mixer and mixed for 30 minutes. Water (more than 50% of the substrate weight) is added and this is thoroughly mixed for another 30 minutes. Gypsum, brown sugar, lime, and calcium carbonate are dissolved respectively and added to the mixture and mixed for last 30 minutes (Fig. 4). Finally, the moisture content is adjusted to 50-55%, which is the optimal water content for the growth of shiitake mycelia. The water content of delivered substrate materials varies according to the supplier, so the added water amount is also varied. I used to use measuring instruments to calculate water content, but now I estimate with my hands. Usually, the substrate mixture contains the appropriate amount of water if the mixture sticks together for a while when a handful is grabbed.



Figure 4. Mixing substrate materials A: Ribbon mixer with watering hose and motor attached B: Mixing substrate materials thoroughly

### Bagging

The mixer is connected to a bagging machine, so the substrate mixture is moved to the bagging machine which fills the substrate into plastic bags (Figs. 5). My mixer can produce about 400 pieces of 3kg bags with one operation. 700kg sawdust and 144kg supplements make the total substrate material weigh 844kg. In most cases, water is added for 50% of the total weight of materials to make the water content be 50-55%. The total weight of the substrate mixture is about 1,266kg and this amount can fill about 400 bags. A filled bag is 12cm in diameter and 38-40cm in length. It is recommended that bagging be done within two hours. The shorter the bagging time, the better. It usually takes about 40 minutes for 4 persons to fill 400 bags; one fits plastic bags in bagging machine, another two tie the filled bags and the last carries them to sterilizer.



Figure 5. Bagging A: Substrate mixture is carried from mixer to bagging machine through conveyer B: Filling bags with substrate mixture

Filled and compacted bags are closed with iron staples (Figs. 6A and B). Iron staples are much better than nylon cable tie because they are much stronger and durable during the high pressure sterilization. Nylon cable ties can become untied during high pressure sterilization. The person who staples also cuts away the extra plastic above the staple (Fig. 6C).

Stapled bags are placed into heat resistant nests and stacks. Four bags fit into one nest and stack. The nest and stacks are moved to the sterilizer by hand pallet truck and they are arranged in the sterilizer (Figs. 7A and B). I have a double door sterilizer; one door is open to the work area where the mixer and bagging machine are located, and the other door leads to the cooling room (Fig. 7C).



**Figure 6.** Tying with staple **A:** Stapler **B:** Bags tied with iron staple **C:** Cutting above the staple



**Figure 7.** Sterilization **A:** Nest and stacks filled with bags on hand pallet truck **B:** Bags arranged in sterilizer **C:** The other side door opens towards the cooling room

### Sterilization

The sterilizer can sterilize 1,200 bags at one time, so the mixer should be operated three times to fill the sterilizer full. It usually takes about 2.5-3 hours for mixing and bagging 400 bags for each operation. Therefore, a 9 hour gap occurs between the first mixed substrate batch and the last one. Lime is used in summer to prevent the substrate from decomposing during the interval.

I am planning to utilize two mixers at the same time which can fill 600 bags each. Then, I will be able to fill the sterilizer with 1,200 bags within 3 hours. I have three growing houses and each of them can be filled by about 3,000 bags. Therefore, I need to operate the sterilizer at least twice to fill one growing house.

The bags are sterilized at 110℃ under 0.5kg/cm for 6 hours. I used to sterilize bags at 100℃ for 10 hours including 8 hours to increase temperature up to 100℃. By sterilizing at 110℃ for 6 hours I have lowered the contamination rate. Moreover, I save fuel costs by reducing the sterilization time.

**April 11, 2004**

Temp. : 9.8/22.2℃ R.H.: 45.3% Rainfall : 0mm Mostly sunny

The sterilized bags were transferred to the cooling room. They will be cooled there all day long because the cooling room is small. They will be inoculated tomorrow after having cooled.

### My farm structure

My farm is designed to minimize the movement of bags from mixing to incubation (Fig. 8). The contamination rate is also minimized by this design. The substrate mixture is moved to the bagging machine and the filled bags are moved into the sterilizer through one door. After sterilization, the bags are moved into the cooling room through the other door. When one door of the sterilizer is open, the other is always closed in order to prevent contamination. After cooling, the bags are inoculated in the inoculation room and then moved to the incubation room and kept there for 2 months. Upon the completion of incubation, the bags are moved to a growing house.

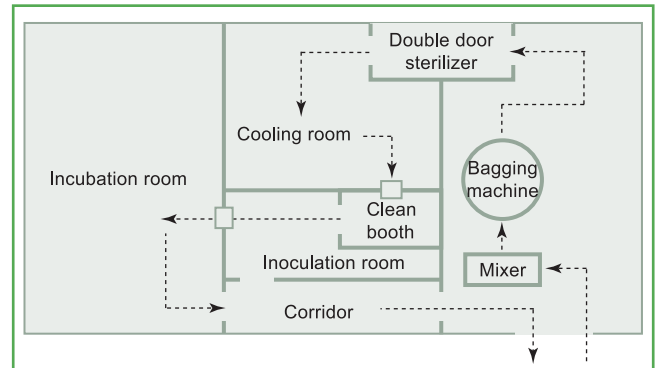


Figure 8. One way voyage of bags from mixing to incubation

### Cooling bags

After sterilization, the chamber is depressurized and then the bags are moved to the cooling room that is equipped with a 10-horsepower cooler (Figs. 9). It takes a relatively long time to cool the bags to 18-20 °C in the current size cooling room, so I am planning to expand it to shorten cooling time. The cooling room and inoculation room are the places where the highest degree of cleanliness is required. The sterilized bags are moved into the cooling room without any contact with outside air, thanks to the double door sterilizer, and then to the inoculation room after cooling. The sterilized bags are empty of microorganisms. If any fungi or bacteria do contact the substrate before shiitake spawn is inoculated, the microorganism will occupy the substrate very easily because it will not need to compete with any other microorganisms. That is why I pay careful attention to maintaining hygiene and sanitation in the cooling room and the inoculation room.

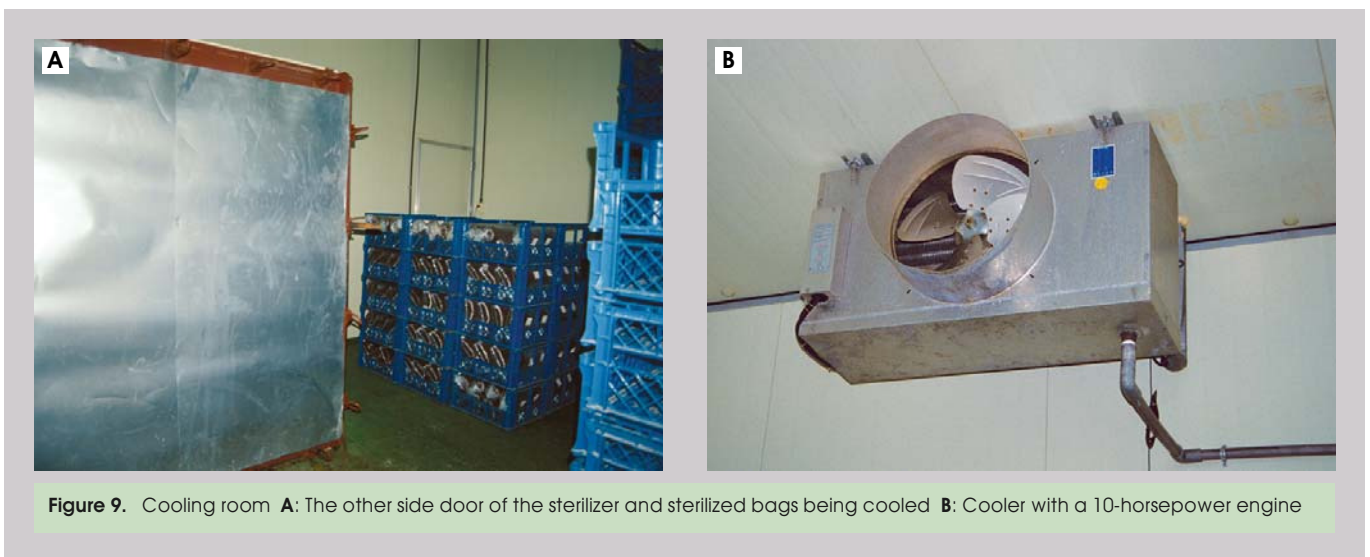


Figure 9. Cooling room A: The other side door of the sterilizer and sterilized bags being cooled B: Cooler with a 10-horsepower engine

April 12, 2004

Temp. : 8.0/22.4 °C R.H.: 66.3% Rainfall : 0mm Partly cloudy

The 1,200 cooled bags were inoculated today and transferred to the incubation room.

### Inoculation

I use sawdust plug spawn<sup>1</sup> for inoculation. After purchasing sawdust spawn, I make sawdust plug spawn by myself with a plug spawn production machine and it is not a complicated process<sup>1</sup>. I use an ozone generator in the inoculation room and in the incubation room to lower the contamination rate. The inoculation room is disinfected with strong ozone (3ppm) from the ozone generator one day before inoculation for 3-5 hours (Fig. 10). A high concentration of ozone can be dangerous enough to kill workers. Therefore, no one should enter the inoculation room during this disinfection and entry should be allowed only after at least 10 hours later than the finish of the disinfection. The inoculation process requires the highest degree of cleanliness, so we wear special suits, masks and hats during inoculation (Fig. 11).

<sup>1</sup> For detailed process of making plug spawn, see SHIITAKE SPAWN PREPARATION CHIEFLY WITH SAWDUST in Chapter 2.



**Figure 10.** Ozone generator attached to the outside wall of the inoculation room



**Figure 11.** My wife and I, wearing suits for inoculation, are holding a plate of plug spawn

There is a pathway equipped with ultraviolet in between the cooling room and the clean booth within the inoculation room (Fig. 12A). The bags are disinfected under the ultraviolet lamp and brought into the clean booth of the inoculation room (Fig. 12B). The temperature within the inoculation room is maintained at 17-20 °C. The ambient temperature should be lower than that of the cooled bags because a higher ambient temperature could increase the bag temperatures and this could cause contamination of the bags.



**Figure 12.** From cooling room to clean booth in inoculation room **A:** Pathway to inoculation room equipped with ultraviolet lamp (the photo is taken from cooling room) **B:** Clean booth in inoculation room

I disinfect the inoculation spots on the bag surface with 70% alcohol and then punch holes in a bag with 5 holes on each side (Fig. 13A). And the plug spawn inserted holes are taped to prevent contamination (Fig. 13B). The inoculated bags are loaded on the rolling conveyor to the incubation room and stacked on shelves with 15 levels in the incubation room (Figs. 14).

#### April 13, 2004

I filled another 1,200 bags after mixing substrate materials. They are being sterilized tonight for 6 hours.

Temp.: 9.9/22.4 °C R.H.: 53.3% Rainfall: 0mm Partly cloudy

#### April 14, 2004

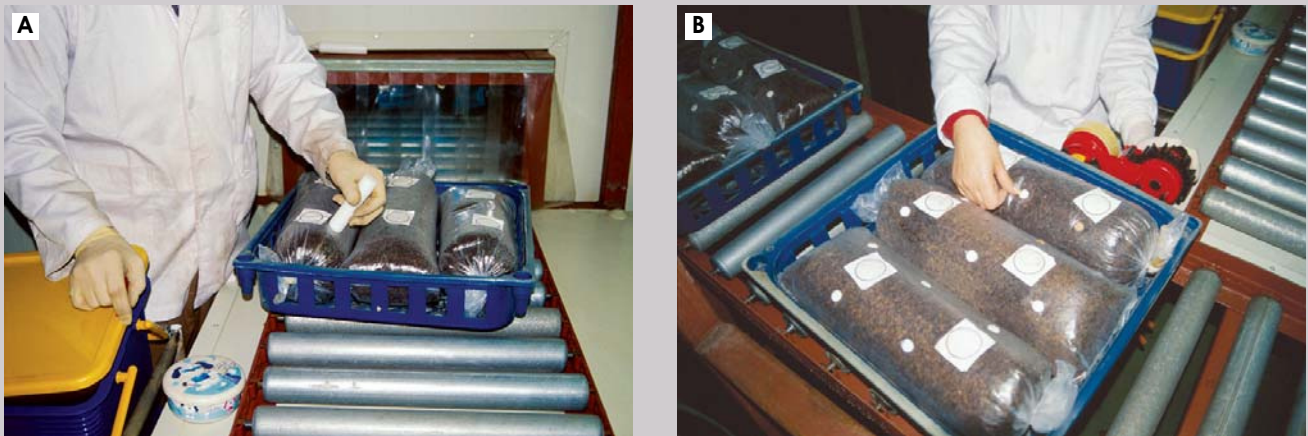
The sterilized bags were moved to cooling room and they will be cooled until tomorrow.

Temp.: 8.0/23.0 °C R.H.: 52.4% Rainfall: 0mm Mostly sunny

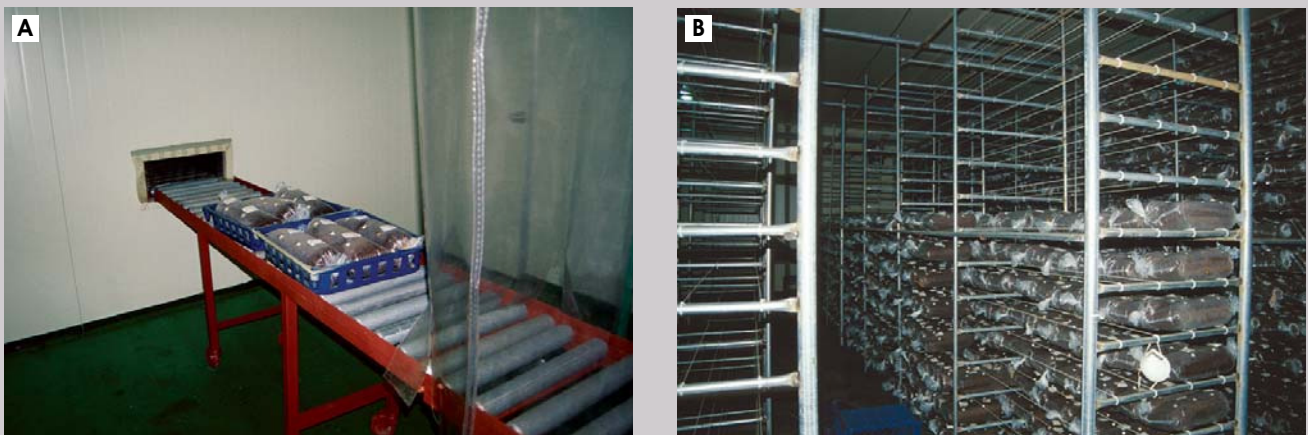
#### April 15, 2004

The 1,200 cooled bags were inoculated today and transferred to the incubation room. Now about 2,400 bags are in the incubation room and they can fill a growing house. I will call these 2,400 bags Lot #1, though there was a 3-day gap between the

Temp.: 5.3/21.6 °C R.H.: 49.4% Rainfall: 0mm Partly cloudy



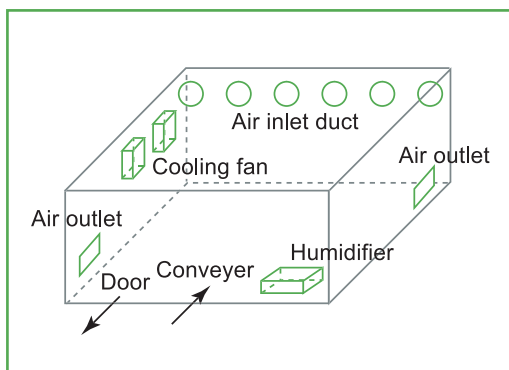
**Figure 13.** Inoculation within clean booth **A:** Plug spawns are inoculated after punching holes **B:** The inoculated spots are taped to prevent contamination



**Figure 14.** From inoculation room to incubation room **A:** Inoculated bags being moved into incubation room through the outlet **B:** Stacked bags in incubation room

first 1,200 bags and the second 1,200 bags. I can not make 2,400 bags at one time because of the small cooling room. After I expand the cooling room, I could place 2,400 bags in the cooling room and inoculate them all in one day. I will assume that I had started incubating 2,400 bags from today.

### Spawn Run

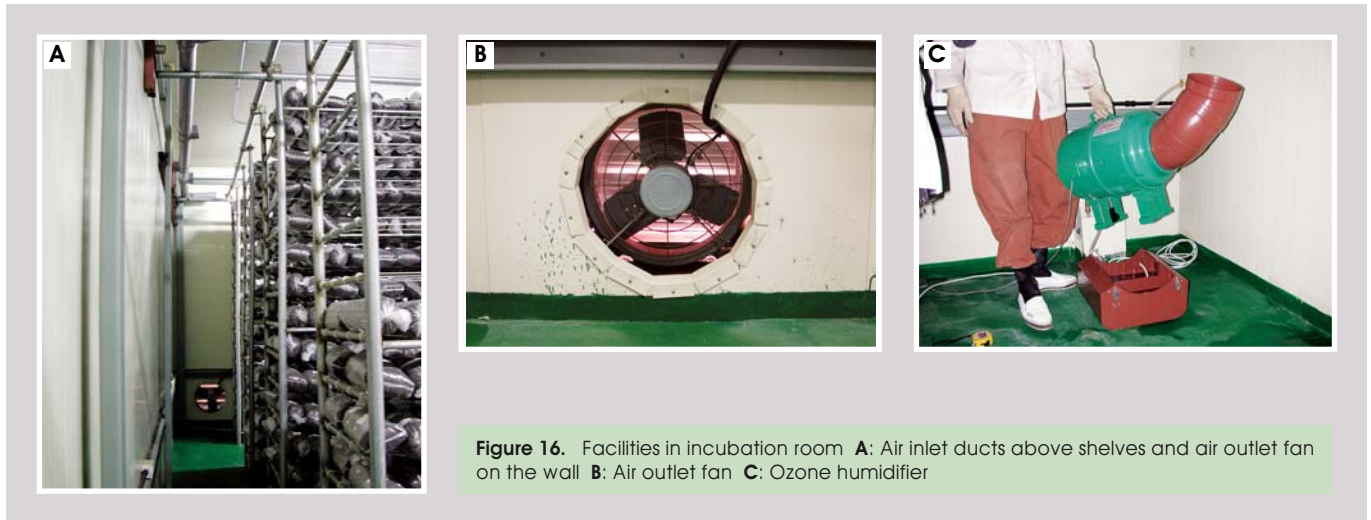


**Figure 15.** Structure of incubation room

Proper incubation for the spawn running is essential to achieving a successful yield. Once the bags are well incubated, the fruiting process gets much easier. The incubation room has air-inlet ducts, two air-outlet holes with a fan, two unit coolers and a humidifier (Fig. 15). The temperature, humidity and CO<sub>2</sub> concentration are controlled during incubation with this equipment. I also use an ozone humidifier that vaporizes ozonized water to lower the contamination rate (Fig. 16C). The ceiling is also equipped with ozone nozzles connected to the ozonizer. 0.2ppm ozone is diffused to incubation room for 10 minutes per hour and controlled by a timer. This concentration of ozone doesn't harm the shiitake mycelia but does prevent contamination.

Ventilation is achieved by inhalation through inlet ducts and exhaust through the fan in my incubation room (Figs. 16A and B). The room doesn't have any windows and all the air comes through a HEPA filter within the inlet and is then distributed into the room through

ducts. I keep a higher pressure inside incubation room, to provoke the natural exhaust of inside air. In this way the air enters the room mainly through the inlet with the HEPA filter.



Chinese shiitake growers prefer strains with a longer spawn run period (4-5 months). However, strains with longer than 60 days' spawn run period are not a good economic choice in Korea because it is very costly to incubate bags for 4-5 months under these controlled environments. I used to incubate the bags for 60 days, but I learned how to shorten the period to 50 days after I had gained a bit of experience.

However, I will incubate the bags for 60 days in this case for the reader's reference. After mastering 60 days' incubation growers might themselves want to find a way to shorten the timeframe. My incubation room is very tightly controlled and this facility has required a large investment. Though the investment is reasonable in Korea due to the high prices and large market for shiitake, another farmer's situation might be different. If the environment for incubation is not controlled, it might take more time for full spawn running.

The stages of the 60-day spawn run period are shown below.

**Table 3.** Each stage of 60-day spawn run period

Stage	Duration(days)	Temperature (℃)	Ventilation	Light	Humidity (%)	
Early stage	7	18	no	darkness	70	
Middle stage	1 <sup>st</sup> half	15	no	darkness	70	
	2 <sup>nd</sup> half	15	a little	darkness	70	
Late stage	Maturity period	10	below 20	a lot	light	70
	Browning period	13	23	a lot	light	70

#### April 16, 2004

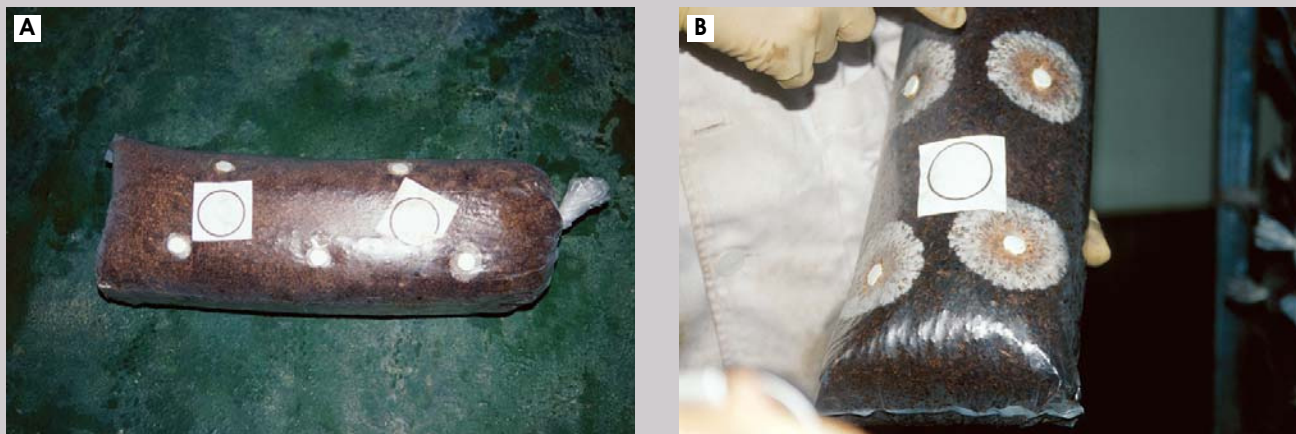
Temp. : 8.9/21.8℃ R.H.: 49.6% Rainfall : 0mm Sunny

All the bags were arranged on the shelves in the incubation room yesterday and they will be incubated there for about 60 days. During the 'Early stage,' the temperature in the incubation room will be adjusted at 18℃. This temperature is not favorable for the growth of green mold or bacteria, thus giving the shiitake mycelia the chance of stable colonization against other weed molds. The relative humidity is maintained at 70% without any controls. No ventilation or light is provided. The same conditions will be provided for 7 days and the shiitake mycelia will grow from the inoculated spots.

#### April 22, 2004

Temp. : 12.7/18.2℃ R.H.: 69.3% Rainfall : 0.5mm Shower

Shiitake mycelia keep growing white from the inoculated spots (Fig. 17B). The first half of the 'Middle stage' has started today. The temperature is being maintained a bit higher at 23-25℃. No ventilation or light is provided and the humidity is about 70% without any control. The same environment will be provided for 15 days.



**Figure 17.** Early stage of spawn run **A:** White mycelia are visible around the plug spawn after 3 days' spawn run **B:** The bags after 7 days' spawn run

### Turning of bags

The bags are turned in each stage of incubation. This turning aims at uniform incubation of each bag. The micro environments between the upper and lower part of bag are different in temperature and light intensity. More even temperature and light can be provided to both sides by turning the bags. In addition, the slight percussion by turning promotes the growth of the shiitake mycelia. Chinese shiitake growers change stacking shapes in each incubation stage, which provides the slight percussion to bags that promotes growth.

I turned the bags today because the 'Middle Stage' has started today (Fig. 18). It is not a difficult job, but quite tricky because the shelves are quite high with 15 levels. I use a ladder for turning bags on the upper parts of the shelves.



**Figure 18.** My wife turning bags during incubation

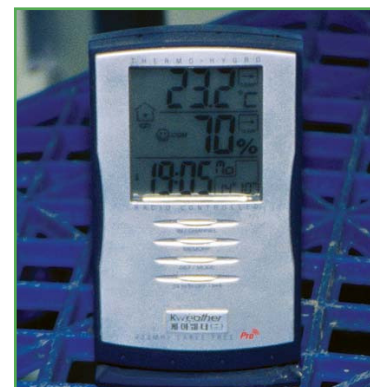
### Exchange of O<sub>2</sub> and CO<sub>2</sub> through filter on the bag

Shiitake mycelia are aerobic, so I use bags with filters of 3cm in diameter on both sides to provide oxygen for the mycelia growth. If the plastic bag has no filter, it is recommended to perforate the parts covered with white mycelium with small punch holes to provide air. Chinese growers using bags without filters usually perforate the bags 3-4 times in concentric circles until the bags are fully colonized, but the filters save me the labor of doing this work. During mycelial growth gas should be allowed to escape from inside the bags through a filter or perforations. Un-ventilated gases inside the bags can damage the shiitake mycelia.

**May 7, 2004**

Temp.: 7.3/24.8 ℃ R.H.: 41.9% Rainfall: 0mm Partly cloudy

The first half of the 'Middle stage' finished yesterday and the second half started today, so I turned the bags. About 70% of each bag has been colonized by the white shiitake mycelia. As mycelial activity becomes more active, the emitted heat increases the temperature in the room. Therefore, the temperature is maintained a bit lower, at 20-23 ℃. The humidity has also begun to be controlled at 70% (Fig. 19). Ventilation started today: one hour in the morning and one hour in the evening. Light is not provided yet. This environment will be continued for 15 days. The ventilation time will be increased little by little, up to two hours both in the morning and evening, within the next 15 days.



**Figure 19.** Digital thermo-hygrometer

**May 22, 2004**

Temp.: 10.8/23.6 ℃ R.H.: 52.8% Rainfall: 0mm Mostly sunny

The 'Late stage' incubation starts today, so I turned the bags again. The first half of the 'Late stage' is called the 'Maturity

period' (10 days) and the rest is the 'Browning period' (13 days). More than 90% of each bag has been colonized by white shiitake mycelia. The bags will be fully colonized soon, so the temperature should be maintained as low as 20℃. The room is ventilated for 2 hours in the morning and evening. These conditions will be continued for 10 days. In addition, lighting will be provided day and night starting today to provoke the alteration from the vegetative stage into the reproductive stage. Browning starts in the 'Maturity period' (the first half of 'Late stage') of 10 days and is completed during the 'Browning period' (the second half of 'Late stage'). Primordia are also formed within the substrate during the 'Maturity period'.

### May 28, 2004

Temp. : 16.5/21.7℃ R.H.: 88.0% Rainfall : 42.5mm Rain

It rained today. During the first half of the 'Late stage' (Maturity period) the temperature is maintained below 20℃, the humidity is at 70%, and there is a 2 hour ventilation in the morning and evening. On rainy days the room does not require the 2 hour ventilation. Exhaust is performed with the fan whenever the air is felt not fresh and when the humidity should be lowered.

### June 1, 2004

Temp. : 12.1/27.8℃ R.H.: 51.4% Rainfall : 0mm Mostly sunny

The first half of the 'Late stage' finished yesterday. The bags are already fully colonized by shiitake mycelia and browning has started during the 1st half of the 'Late stage'. The second half, the 'Browning period', has started today, so I turned the bags. Browning will be completed during this period of 13 days. The temperature is adjusted at 23℃, the humidity at 70%, and lighting and much ventilation are provided.

I took 200 bags (I will call them Group #1) randomly and transferred them to growing house #1 where shiitake fruiting bodies from previously transferred bags are being produced. The group #1 bags will be browned in the growing house while the others (I will call them Group #2) will be browned in the incubation room. I will later compare the Group #1 bags to the Group #2 bags in the incubation room.

The browning period is critical in producing high quality shiitake. Though the shiitake mycelia moved into the reproductive stage during the 'Maturity period', it is recommended to also have a 'Late maturity' period in order to produce higher quality for a longer period.

Based on my own experience, I recommend completing the full incubation period even though the bags look fully incubated before the incubation period ends. When fruiting is induced without having completed the incubation period, the shiitake quality was not high. This seems to be because the shiitake mycelia are not yet mature enough to produce high quality fruiting bodies. Of course, the substrate formulation also has some effect on the incubation period and the quality of fruiting bodies.



Figure 20. Browned bags in incubation room

### June 4, 2004

Temp. : 17.8/30.4℃ R.H.: 54.5% Rainfall : 0mm Partly cloudy

Browning is going on both in the incubation room and in the growing house. The bags in the growing house are shrinking as browning goes on, so there is a gap between the plastic bags and the substrate.

### June 7, 2004

Temp. : 18.6/24.7℃ R.H.: 49.8% Rainfall : 0mm Cloudy

I found green mold growing on some bags in the growing house because of the very high relative humidity and the gap between the plastic bags and the substrate. I always keep the plastic bags on during the browning in the incubation room, but I decided to peel off the bags now to minimize the contamination rate. The group #1 bags in the growing house are all peeled off while the Group #2 bags in the incubation room are still wearing the plastic bags.

## Shiitake Growing House

I estimate that the spawn running of the bags will be complete by June 13<sup>th</sup> and expect to transfer them to the growing house. Growing house management<sup>2</sup> is very important, especially during the hot summers. The outside temperatures are very high for shiitake fruiting, so the inside temperature and humidity must be controlled properly to achieve high yield.

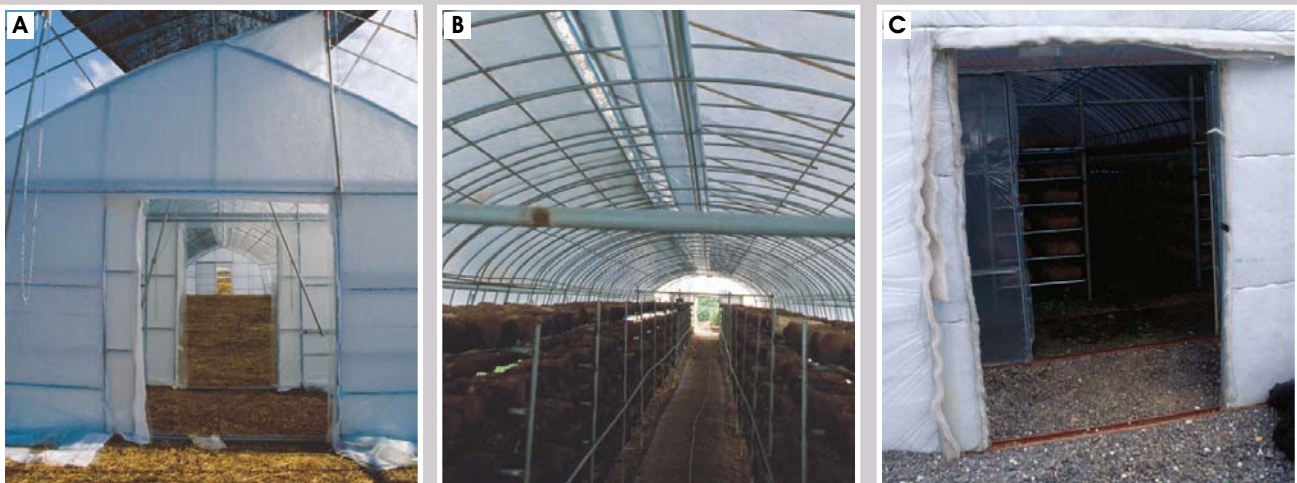
<sup>2</sup> For detailed information on growing house management, see SHIITAKE GROWING HOUSE-KOREAN CASES in Chapter 6.

June 12, 2004

Temp. : 17.7/30.5℃ R.H.: 43.9% Rainfall : 0mm Mostly sunny

Today I checked the growing houses to see whether there were any problems. I have three growing houses and previously incubated bags are fruiting shiitake in the houses. I haven't previously written about my working with the already incubated bags lest it confuse the reader. Old substrates from which the eighth flushes have been harvested were removed from growing house #1 in order to make room for the newly incubated bags which are being incubated in the incubation room. Now, only the Group #1 bags remain in growing house #1.

I am paying a lot of attention to the growing house management now because it is summer. Because shiitake prefers temperate climates, special care is required to grow shiitake in hot summers. Therefore, I have built the growing house with an open roof that allows me to meet the picky requirements for fruiting shiitake in the summers. The temperature inside the growing house with the open roof is lower than the temperatures inside the typical growing houses without the open roof by 10℃ on sunny days and by 5℃ on cloudy days in summer. The open roof growing house also costs less to build than the ordinary panel growing houses. My open roof growing house has a triple structure; the inner plastic covers the shelves and the outer structure covers the inner structure. Shade net covers the outer structure (Figs. 21A, B and C). This growing house is characterized by an open roof. This partly opened and overlapped roof enables abundant ventilation to lower the temperature while it still prevents rain or snow from coming inside the building. The ground inside the growing house is covered with gravels or yellow soil to prevent contamination. The ground under the shelves is a bit lower than the aisles to let water drain away.



**Figure 21.** Growing house **A:** Triple structure of growing house **B:** The outer structure with partly open roof and the inner structure with plastic rolled up **C:** The outer structure made by two sheets of plastic cover and chemical cashmilon within

## Induction and Fruiting

June 13, 2004

Temp. : 16.4/26.5℃ R.H.: 48.9% Rainfall : 0mm Sunny

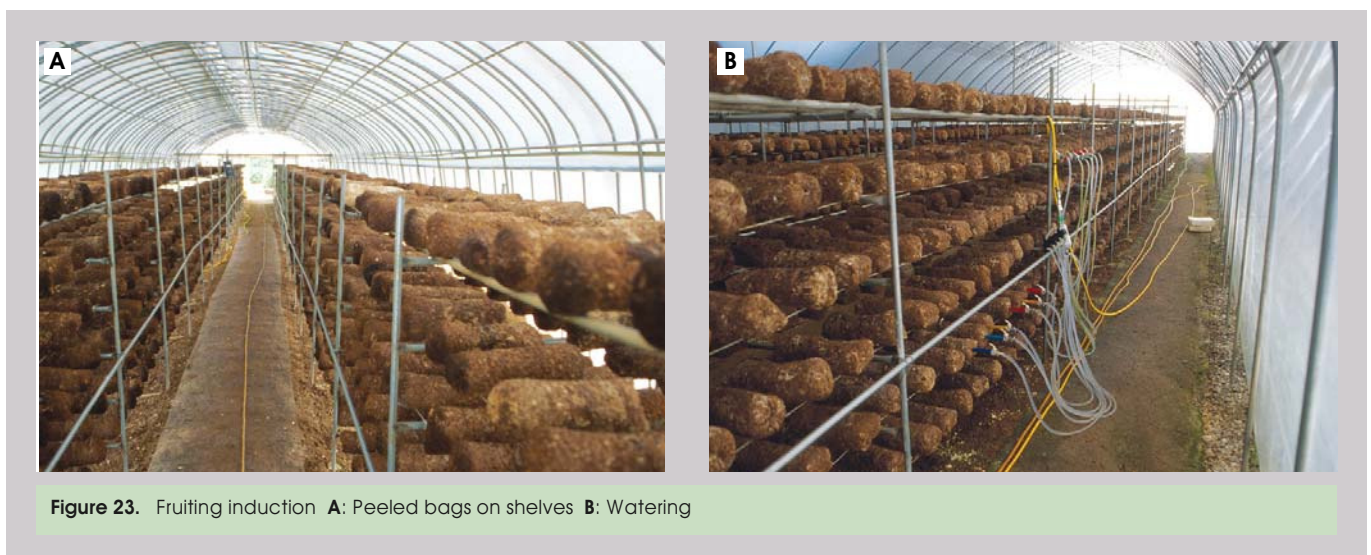
The Group #2 bags which had been matured in incubation room were transferred to the growing house #1 today. The 2,200 bags were transferred by truck from incubation room to the growing house (Fig. 22A). The bags were carried into growing house by handcart (Figs. 22B and C). I arranged the group #2 bags on the shelves with two rows of 6 bags on each level (Fig. 22D). My shelves have 6 layers in total.

As soon as all the bags of Group #2 were arranged on the shelves, I peeled off the plastic bags to induce fruiting (Fig. 23A). I usually keep the plastic bags on the synthetic log during fruiting and harvesting, but I peel them off when I am growing high temperature strains. This is because the high temperature strain forms a lot of pins in the first flush and it is very laborious to make holes for the numerous pins. From the second flush, however, much reduced number of fruiting bodies are formed. The high number of pins in the first flush doesn't affect the life span of the bag. The physical shocks caused by the transfer are enough to induce the first flush. The high temperature strain is induced to fruit when the temperature is at around 20℃. Fruiting induction is the most crucial step in shiitake bag cultivation because the induction stage decides much of shiitake quality. Therefore, optimal temperature and humidity should be provided for fruiting induction. The temperature is maintained at 23-25℃ and the humidity at 70-90%. When the surface of the bags is dry, it is very hard to get pins.

Therefore, water should be sprayed in the growing house in the morning and evening. Ventilation is not essential for fruiting induction, but the side wall is opened and closed to control the temperature.



After the plastic is peeled off, the bags are watered enough to provide enough moisture to the surface of substrate (Fig. 23B). Though the relative humidity is quite high in summer, wind dries the moisture from the surface of the substrate. Therefore, enough watering is required to maintain the humidity and soften the peeled substrate blocks. For one day after filling the shelves, I keep the growing house closed to maintain stability.



**June 14, 2004**

Temp. : 15.8/29.3℃ R.H.: 46.0% Rainfall : 0mm Partly cloudy

I started ventilation today. I rolled up the inner plastic to the end and opened the plastic of the outer structure to 80cm above the ground. The bags are more likely to be attacked by green mold if sufficient ventilation is not provided. I should see pins in the substrate soon. It takes about 3-4 days for fruiting induction and 7-10 days for fruiting development, so it takes a total of 10-14 days from induction to harvest for the high temperature strains.

**June 15, 2004**

Temp. : 16.3/30.8℃ R.H.: 43.8% Rainfall : 0mm Partly cloudy

Two days have passed since I transferred the bags into the growing house. I have compared the Group #1 bags as they browned and matured in the growing house with the Group #2 bags that were browned in the incubation room. Thick brown bark has formed for the Group #1 bags. I think this is mainly due to the strong light as well as the fluctuation of temperature between daytime and nighttime. The thick bark of the substrate hinders the pinning of fruiting bodies and the wider fluctuation of temperature than that of the incubation room provoked an excessive amount of primordia. However, it is very hard for these primordia to penetrate the thick bark, so many of them will die within the substrate. On the other hand, it seems to be because the fluorescent lighting within the incubation room is much weaker than the indirect sunlight in growing house, so the bark of the Group #2 substrate bags that were browned in the incubation room is soft and thin, which makes pinning much easier.

I performed this test to see whether I could incubate more bags in the incubation room by incubating a batch of bags for shorter period of 47 days in the room in order to be able to produce more shiitake bags. If the bags could be successfully browned in a growing house, I would brown them in the growing houses after incubating for only 47 days in the incubation room. This would have made the operation of the incubation room more efficient. However, as a result of this test I have concluded that I had better not make this change.

**June 19, 2004**

Temp. : 20.0/22.6℃ R.H.: 87.3% Rainfall : 89.5mm Rain

It has been raining for three days. The weather forecast said the rainy season will be over next week. Korea, as well as Japan and China, has a rainy season in early summer and then the hot and humid summer continues for 1-2 months.

When the relative humidity is very high, as it is today, the shiitake bags are easily contaminated by green molds. The optimal relative humidity for high quality shiitake is 65-70%, but the actual humidity here is as high as 70-80% even in the hot summer which comes after rainy season. Therefore, I need to lower the humidity by ventilation in order to harvest high quality shiitake. Small pins are now visible on the substrate. High temperature strains have a reliable fruiting schedule, and it takes 3-4 days for fruiting induction, 7-10 days for fruiting and harvesting, and 5-7 days for rest. A total of 15-21 days are required for one flush. On the other hand, the harvest of a low temperature strain cannot be divided by flush. Though the quality is lower, the high temperature strain is more appropriate for yields planned according to market price. If the price is low I can keep the shiitake substrate resting. If the price goes higher, I can induce the next flush and supply shiitake at the higher price. Shiitake sells at twice the usual price on special occasions including Korean Thanksgiving Day. Therefore, I can control my cropping day to meet these peak days by cultivating a high temperature strain.

**June 20, 2004**

Temp. : 20.1/24.1℃ R.H.: 86.9% Rainfall : 6.5mm Rain

It keeps raining. Some of the fruiting bodies have grown large enough to be harvested. I harvested about 20kg today. The harvest will go on for 7-10 days as fruiting bodies develop asynchronously. When the harvest ends, the bags will rest for a week.

The Korean summers are very humid and hot. Therefore, the most difficult problem is lowering the relative humidity. Humidity can be easily controlled by running a humidifier when the relative humidity is low.

**June 24, 2004**

Temp. : 20.4/29.5℃ R.H.: 71.7% Rainfall : 0mm Cloudy

The shiitake is growing very well and we have harvested about 14kg per day. The first flush of a high temperature strain has many fruiting bodies (Figs. 24A and B). This year I have for the first time myself grown a high temperature strain. I used to cultivate low temperature strains even in summer by controlling the temperature with an air conditioner, but I was not successful in growing a low temperature strain in summer when the outside temperature was over 30℃. The high temperature strain is now fruiting without any difficulties in my growing house, but the quality of the fruiting bodies is much lower than that of the low temperature strain. The rate of flower shiitake (the highest quality of shiitake) is up to 40% when a low temperature strain is cultivated. However, this is my first trial with a high temperature strain. I believe the quality of the high temperature strain will be improved by repeating cultivation every summer as my experience with it will increase.

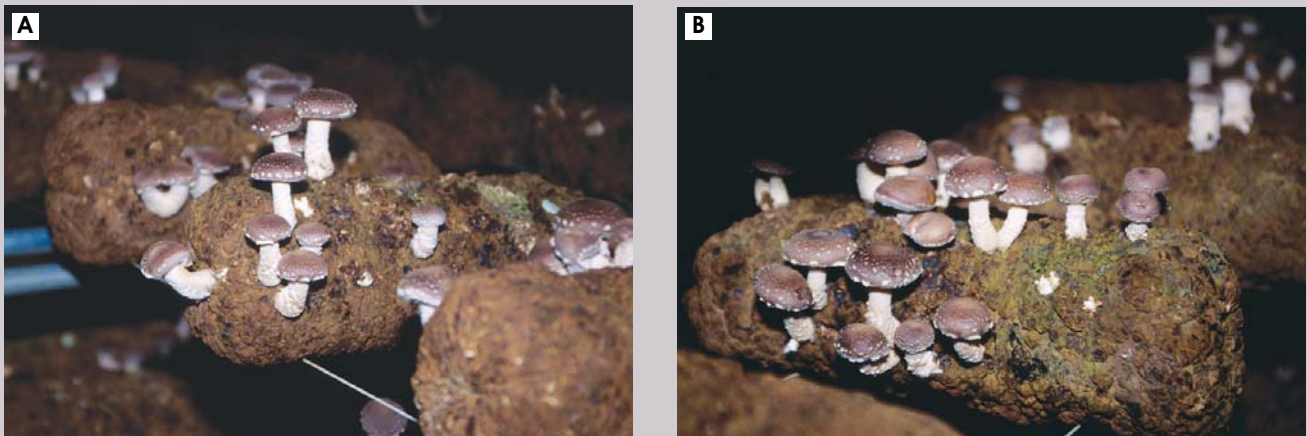


Figure 24. The first flush with many fruiting bodies

It is hot summer with high humidity, so I cannot find flower shiitake and the currently produced shiitake is fair to average in quality. Shiitake is harvested everyday and stored in the refrigerator. They are supplied after trimmed every other day because I use the collecting car that comes every second day to minimize transportation costs (Fig. 25). I supply my shiitake to the Suwon Agricultural Wholesale Market. They are sold by auction, so the price fluctuates according to supply and demand. The price goes up in the hot summer and cold winter when enough shiitake is not produced from logs. In addition, it also increases around Korean Thanksgiving day (September or October) and Korean New Year's Day (January or February) due to the temporary surge of demand.



Figure 25. Trimming and packing

### June 26, 2004

Temp.: 21.1/28.7℃ R.H.: 71.3% Rainfall: 1.0mm Shower

Harvest of the first flush in Growing House #1 (both from Group #1 and 2) has almost finished. I harvested 300kg shiitake from 2,400 bags during the 1st flush. The quality is medium and I got an average of KRW<sup>3</sup>5,200 (USD5.2) per kg. The substrates are resting after harvesting the first flush. Usually, they rest for 7 days after cropping, but I will let them rest a little more before inducing a second flush because they produced more fruiting bodies than usual in the first flush. A lot of fruiting bodies does not guarantee high productivity. The first flush has a lot of pins, so many of them, mostly the smaller ones, are thinned out.

### July 5, 2004

Temp.: 19.3/27.3℃ R.H.: 79.5% Rainfall: 7.0mm Rain

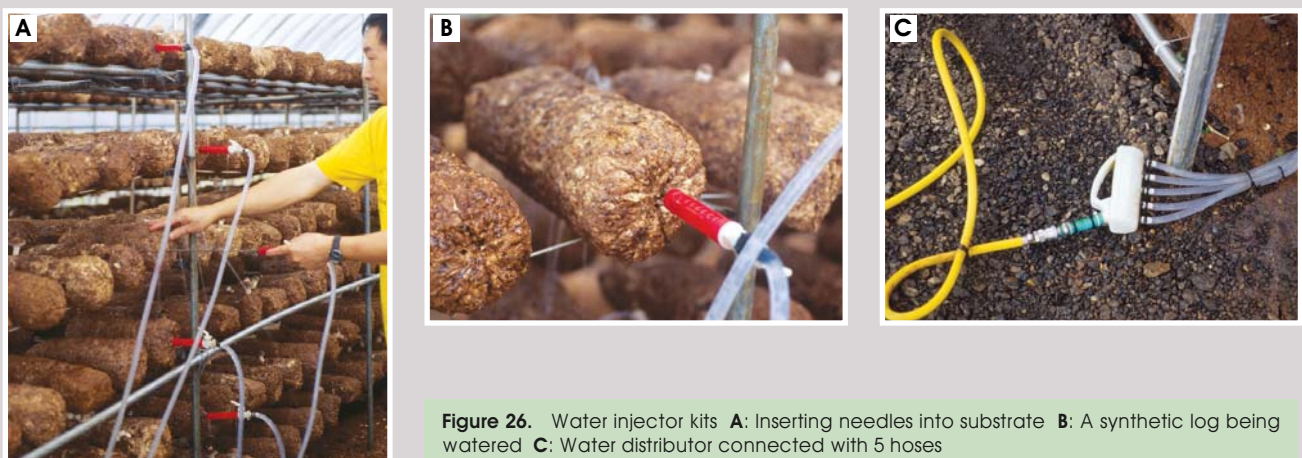


Figure 26. Water injector kits A: Inserting needles into substrate B: A synthetic log being watered C: Water distributor connected with 5 hoses

<sup>3</sup> KRW(Korean Won, USD1 = KRW1,000 in March, 2005)

The substrates have rested for 10 days since the harvest of the first flush. I induced the second flush by watering. A low temperature shock is not required because the daytime temperature and nighttime temperature differ by more than 10℃ nowadays.

I use a water injector for watering. This injector is very effective and easy to use. It consists of needles, hoses, and a water distributor. The water is divided into five thin hoses through the distributor and each hose is connected to a each needle (Fig. 26C). Needles are inserted into the center of bags (Figs. 26A and B). Each needle has many holes on its body and water comes out through the holes into the substrate. Regular watering with a hose cannot penetrate the brown bark, but this injector forces water inside the substrate.

**July 10, 2004**

Temp. : 19.1/28.6℃ R.H.: 75.3% Rainfall : 0mm Partly cloudy

I started to harvest the second flush. A smaller number of shiitake is fruiting per bag than the first flush and the quality is better than the first flush (Figs. 27). So, I am getting a higher price per kg for the second flush.



**Figure 27.** Smaller number of shiitake per bag in the second flush

**July 18, 2004**

Temp. : 23.0/29.3℃ R.H.: 79.9% Rainfall : 0mm Cloudy

The harvest of the second flush has almost finished. I harvested about 320kg from 2,400 bags in the second flush. Most of the harvested shiitake are medium high quality (Figs. 28). It is very hot nowadays; the highest temperature is up to 30℃. It should be reminded of that shiitake harvest from logs in this season has been known impossible due to the high temperature. The price is quite high perhaps because of the low supply; I got an average of KRW7,000 (USD7) per kg for the second flush. The bags will rest starting today.



**Figure 28.** Harvested shiitake (the second flush)

**July 26, 2004**

Temp.: 23.7/30.4℃ R.H.: 75.9% Rainfall: 0mm Cloudy

**Growing house #1**

I started inducing the third flush by watering. Shiitake pins will show up within several days.

**Growing house #2**

Today, I also transferred 1,980 fully colonized (browned and matured) bags in the incubation room into Growing House #2. I will call these 1,980 bags Lot #2. These bags were inoculated with a high temperature strain in late April and have been incubated for 100 days in the incubation room. I was planning to build a new growing house after 60 days' spawn run and these bags were supposed to fruit the new one. However, the construction was delayed and these bags have been incubated 40 more days than the other bags. Though the transfer was delayed due to a lack of space in the growing house, I can harvest a second flush from these bags right before Korean Thanksgiving Day when shiitake prices are the highest, thanks to this delay. I peeled off the bags, but didn't water because the substrate contained much moisture. These bags have a high water content because they have absorbed much exudate generated from browning during the extended late maturity period. The mycelia have deactivated due to excessive water content, so they need to be dried to activate the mycelia. If not dried, it would be possible to get nothing from the bags. They could be dried enough within 5 days, I think.

**July 30, 2004**

Temp.: 23.7/33.2℃ R.H.: 67.0% Rainfall: 0mm Sunny

**Growing house #1 - Lot #1**

After inducing the third flush 4 days ago, the shiitake is growing well. I could harvest some shiitake starting tomorrow.

**Growing house #2 - Lot #2**

The bags are being dried. During the extended late maturity period, fully matured primordia were not able to fruit because the temperature in the incubation room was not appropriate and a physical shock was not provided. Stressed by the inappropriate environment, the shiitake primordia were on standby for fruiting. Once they got a physical shock during the transfer and an appropriate temperature for fruiting and enough oxygen after the bags were peeled off, however, all the standby primordia were matured into pins. High temperature strains are very sensitive to physical shock, so the number of pins reached above 40-50. Therefore, I am getting rid of most of them, leaving only 5-7 fruiting bodies to get better quality shiitake.

**August 2, 2004**

Temp.: 23.7/33.0℃ R.H.: 67.5% Rainfall: 0mm Partly cloudy

**Growing house #1 - Lot #1**

Fruiting bodies of shiitake keep growing, and I harvest some of them everyday.

**Growing house #2 - Lot #2**

The bags are dried enough. I expected that they would be dried enough within 5 days, but it took a week, a bit longer than I expected. I watered today to induce the first flush.

**August 11, 2004**

Temp.: 24.7/35.1℃ R.H.: 57.6% Rainfall: 0mm Sunny

**Growing house #1 - Lot #1**

I have harvested the third flush for 11 days. The harvest of the third flush has finished today and the bags will rest for several days.

**Growing house #2 - Lot #2**

The harvest of the first flush has finished today. I have harvested 358kg from 1,980 bags in 9 days. It means that I harvested about 180g per bag for the first flush. The highest price in August was KRW9,230 (USD9.2) per kg. I have been getting an average of KRW7,000 (USD7) since July and this price is much higher than the average annual price of KRW5,198 (USD5.2). Therefore, I can make much more money if I can produce high quality shiitake in summer. I need more trials and investment to produce higher quality in summer.

**August 12, 2004**

Temp.: 24.2/37.3℃ R.H.: 60.9% Rainfall: 0mm Sunny

This summer is really hot. However, the open roof growing house is very effective at keeping a lower temperature. The high daytime temperatures have been 35-37℃ for a week, but the temperature inside the growing house is maintained at about 28℃ by opening and closing the side plastic covers. I also water the growing house with underground water at 15℃ when the

inside temperature increases up to 30℃ and I can thereby lower the temperature by 3℃.

----- 45 days later -----

## September 27, 2004

Temp. : 14.8/26.1℃ R.H.: 71.8% Rainfall : 0mm Mostly sunny

This year Korean Thanksgiving holiday started on September 26. Thanksgiving Day is very special for shiitake growers in many aspects. I have managed to get shiitake from all the bags in the growing houses in order to supply shiitake at the high price before the Thanksgiving holiday. I have supplied most of them by direct transaction.

I found that I could get a much higher price than usual by providing shiitake directly to consumers by telephone orders. I can get as much as KRW15,000 (USD15) per kg in these sales. This price is much higher than that for direct transactions at ordinary times it is about 3 times the average annual wholesale price. Direct transactions are beneficial to both the consumer and me because consumers can thereby get fresh shiitake. On the other hand, the auction price in the wholesale market was not better than that in summer because I sold the higher quality mushrooms directly to the consumers and the rest to the wholesale market.

## Conclusion

### Cost and benefit

I have harvested 2,793kg from 2,400 bags, so a bag of 3kg has produced average of 1.164kg through 8 flushes. I sold 85% of them to wholesale market and 15% directly to consumers. I supplied 2,374kg to the wholesale market at an average price of KRW5,198 (USD5.2) per kg, from which I earned KRW12,318,686 (USD12,318.7). I also sold 419kg directly to consumers at an average price of KRW10,000 (USD10), from which I earned KRW4,190,000 (USD4,190). For the 2,400 bags which I have written about, the average shiitake price per kg was KRW6,878 (USD6.9) and the total value of sale was KRW16,508,686 (USD16,508.7).

Cost of production includes labor costs, material costs, packing costs, electricity, fuel costs, management costs, and depreciation costs of fixed property such as land, spawn production facilities, incubation facilities, and growing houses.

The depreciation costs for the machines are calculated with a 5 year's duration and that for a building with 10 year's duration. In my case, the production cost per bag is KRW1,100 (USD1.1), so the production cost for 2,400 bags is KRW2,640,000 (USD2,640). (My own labor cost is not included.) In addition, I have paid KRW1,096,800 (USD1,096.8) for 2,400 bags as market fees such as handling fees, transportation costs, auction fees, and so on. This corresponds to KRW457 (USD0.46) per bag. This cost is really high, so I do prefer direct transactions. In total the net profit from 2,400 bags is KRW12,771,886 (USD12,771.9) and net profit from a bag is KRW5,321 (USD 5.3).

**Table 4.** Value of sale from 2,400 bags

	Volume of sale (kg)	Price per kg in KRW	Value of sale in KRW
Wholesale market	2,374	5,198	12,318,686
Direct transaction	419	10,000	4,190,000
Total	2,793	6,878 (USD6.9)	16,508,686 (USD16,508.7)

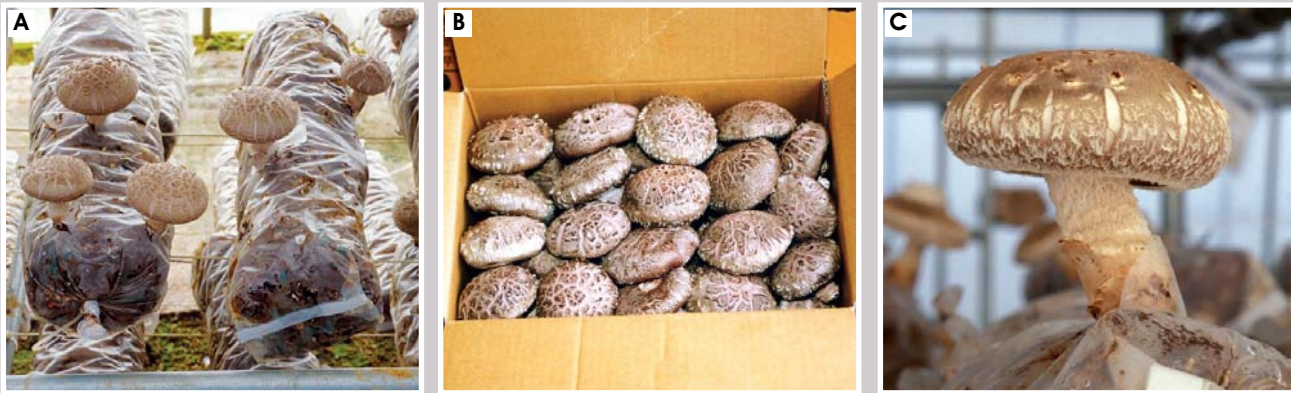
Production cost: 2,400 bags × KRW1,100 = KRW2,640,000 (USD2,640)

Market charge: 2,400 bags × KRW457 = KRW1,096,800 (USD1,097)

Net profit = Value of sale - Production cost - Market charge  
 = KRW16,508,686 - KRW2,640,000 - KRW1,096,800  
 = KRW12,771,886 (USD12,771.9)

## Epilogue

The weather is getting cold and winter has already come. I am harvesting low temperature strains nowadays. The quality is much better than the high temperature strain (Fig. 29). Before concluding this farm diary, I would like to briefly introduce shiitake cultivation in winter and my future plans.



**Figure 29.** High quality shiitake (low temperature strain)

As I wrote before, I don't peel off plastic bags for low temperature strains. The plastic bag helps the substrate to retain moisture content in the substrate and it is one of the important factors in getting high quality shiitake. When pinning starts, therefore, I have to make the cuts at the pinning spots on the plastic bag to help the fruiting bodies come out (Figs. 30). This is a very laborious job as I grow shiitake at a large scale. One day I got a phone call from my friend in China. He introduced to me a newly released plastic bag which didn't require cutting plastic bag for the pinning to grow. It was a very thin plastic film in which young fruiting bodies can manage to go through as they grow out. I was very happy about the new bags and imported some as samples. However, the result was not satisfactory. Though the fruiting bodies penetrated the plastic bags, they were somewhat distorted during penetration (Fig. 31A). This decreased the shiitake price, so I tore the plastic bags for each fruiting body again.



**Figure 30.** Cutting plastic bags for fruiting bodies to grow

I also tried coating synthetic logs with liquid paraffin (white oil) as a drying retarding agent after peeling off the plastic bags after browning (Fig. 31B). It was very effective at keeping the enough moisture within the substrate, and I didn't need to cut the plastic bags. However, I was not quite sure whether liquid paraffin is okay for human health, so I stopped using it.

During my travel in Zhejiang, China, I found other alternative methods to plastic bags. A government organization was testing with various possible drying retarding agents. One was mainly starch and the other was vegetable oils (Figs. 31C and D). The detailed composition of these coating agents was not disclosed. Once I had tried a with starch-based coating by myself, but it was easily watered away. This was found to be fatal flaw because the substrates are supposed to be watered many times until fruiting stops. The vegetable oil-based coating looked very good, but I could not find the detailed composition. I am trying various compositions to identify

the solution by myself.

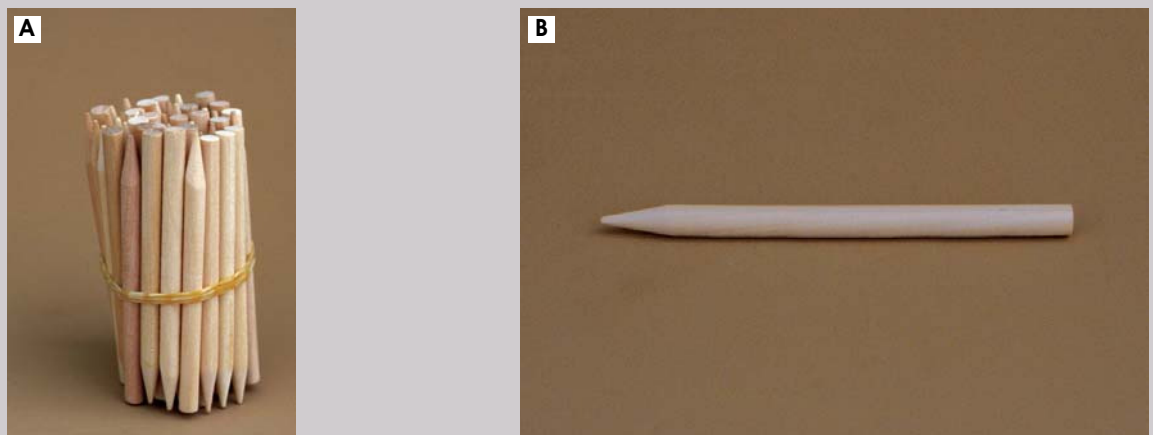
I am also planning to use another type of shiitake spawn, the wood dowel (Figs. 32). Once colonized by shiitake mycelia, the wood dowels can be a very good spawn media that are easy to inoculate substrate bags. They are long enough that I don't have to inoculate both sides of the bag. I am planning to inoculate a bag with only 3-5 dowels per bag. Punching is not required for inoculation because the dowel itself can punch the bag with a conical point.

My facilities for bag production and spawn run are much bigger than those for the growing houses. I am therefore planning to operate a bag distribution center where colonized shiitake bags are delivered to shiitake growers who only fruit and harvest shiitake. Actually, quite a few people are waiting for my fully colonized shiitake bags, encouraged by my success. The operation of a "Bag Distribution Center" may be a challenge for me.

I believe a new challenge can always produce fruit. Though one might fail in these kinds of trials, a farmer should remember that he got an important lesson at least and that will be a step forward towards the future success.



**Figure 31.** Alternative methods for plastic bags **A:** Thin plastic bags **B:** Liquid paraffin-based coating **C:** Starch-based coating **D:** Vegetable oil-based coating



**Figure 32.** Wood dowel before shiitake mycelia is inoculated **A:** A batch of the dowels **B:** A piece of the dowel

## Part I Shiitake

## Chapter 5

Pest and Disease Management of Shiitake**BIOLOGY AND CONTROL OF PESTS AND DISEASES IN SHIITAKE LOG CULTIVATION**Won-Chull Bak<sup>1</sup> and Hyunjong Kwon (Miji)<sup>2</sup><sup>1</sup>Korea Forest Research Institute, 207, Cheongnyangni 2-dong, Dongdaemun-gu, Seoul, 130-712, Korea (wcbak@foa.go.kr)<sup>2</sup>MushWorld, Korea**Introduction**

A wide range of pests and diseases occur during shiitake log cultivation. Some diseases destroy or damage the shiitake mushrooms, and insects and other animal pests also reduce yields and quality. It is impossible to block other wood-inhabiting fungi from the logs used in the outdoor cultivation of shiitake, because the spores of wood-inhabiting fungi are naturally carried in the air. These spores can quickly establish a new colony when exposed to a suitable substrate under favorable conditions. However, if the growing environment is properly managed, pest fungi could not present a serious problem.

Pests which affect the logs, mycelium, fruiting bodies and harvested mushrooms, can be divided by organism type (*i.e.* microorganism, insect, or mammal) and affected site (log, mycelia, shiitake fruiting bodies (growing/harvested)).

**Table 1.** Pests and diseases affecting shiitake cultivation

		Logs	Mycelia	Fruiting bodies	Stored mushrooms
Fungi	Dry	<i>Diatrype</i> , <i>Schizophyllum</i> , <i>Coriolus</i> , <i>Stereum</i>	<i>Hypocrea</i> , <i>Hypoxylon</i>		
	Humid	<i>Coriolus</i>	<i>Trichoderma</i>		
	Hot & Humid	<i>Bulgaria</i> , <i>Inonotus</i>	<i>Nitschkia</i> , <i>Trichoderma</i>		
Insects		<i>Moechotypa</i> , <i>Xylebrorus</i>		<i>Dacne</i>	<i>Nemapogon</i>
Mollusca				Slugs, Snails	
Mammals		Mice, Squirrels		Mice, Squirrels Deer, Rabbits	

Pests cannot be completely controlled by chemicals, and there are other problems with chemical use. Fungicides can also kill the desired fungus, shiitake. The desirability of organic food that has been produced without using chemicals is an important recent trend. The prolonged use of chemicals may lead to some kind of resistance to the chemicals in the pest population. To minimize disease problems and to favor the growth of shiitake it is important to provide optimum growing conditions and practices based on a full understanding of the biology of shiitake and the pests. This knowledge involves biology of shiitake, plant pathology, entomology and zoology.

### Basic Practices for Disease and Pest Management

- ▷ Maintain the proper moisture content of log for shiitake growth: between 30 and 50%.
- ▷ Provide good ventilation and drainage. Damp conditions favor the growth of shiitake's competitors.
- ▷ Do not expose the logs to direct sunlight. Shiitake mycelia may suffer water-lacking stress under dry conditions.
- ▷ Perform timely inoculation of logs in order that shiitake could pre-occupy the logs.
- ▷ Eliminate or exclude the contamination sources. Contaminated soil, piles of dead leaves and mushroom stubs after harvest can be a possible access for disease, competitor and weed fungi to shiitake fungus.
- ▷ Remove spent and contaminated logs immediately.

## Fungi

Pest fungi can be divided into three categories based on the degree of damage inflicted. Disease fungi are capable of attacking and killing shiitake mycelium. Competitor fungi do not actually attack shiitake, but they do diminish the crop by occupying space and withdrawing nutrients from the logs. Weed fungi, while not usually a problem, limit the growing area of shiitake.

### Hypocrea schweinitzii (asexual stage: *Trichoderma longibrachiatum*)

Disease fungus, dry, freshly inoculated logs



Figure 1. *Trichoderma longibrachiatum*

This fungus occurs when the logs are exposed to direct sunlight for at least one day. It causes serious damage by producing antifungal compounds that lead to the cessation of shiitake mycelial growth.

#### Morphology and symptoms

In the asexual stage (*Trichoderma longibrachiatum*), a white colony appears on the bark surface of the log. The colony grows bigger, with the center of the colony growing into a green button-shape. As time passes, the green buttons turn brown or dark brown.

#### Conditions of occurrence

This fungus always exists in and around a log stacking yard, but presents no damage to the shiitake logs unless the logs are exposed to direct sunlight. Warm temperature or low moisture content inside the logs can lead

to high population of this fungus in the logs.

#### Control measures

- ▷ To prevent the infection, avoid direct sunlight by using shade netting.
- ▷ Protect shiitake mycelia from high temperatures by providing sufficient shade.
- ▷ Logs heavily infected by *Trichoderma* should be removed from the fruiting site to stop the dispersal of *Trichoderma* spores.

### Hypoxylon truncatum

Disease fungus, dry, mid temperature

*Hypoxylon* can be a serious problem during shiitake cultivation. They are antagonistic to shiitake and can stop its growth. *Hypoxylon* invades logs during the early spring months.

#### Morphology and symptoms

A yellowish green colony (asexual stage) appears initially on the log ends. The colony spreads towards the bark surface and results in stroma<sup>1</sup> formation.



Figure 2. Asexual stage and stromata of *Hypoxylon truncatum* on the log end

<sup>1</sup> stroma : pl. stromata. a compact mass of somatic hyphae

Fruiting bodies start as tiny dark spots, usually in cracks in the bark. During the late summer months, the dark spots gradually develop into small, hard, brick-red to black molds, usually less than 3/8 inch (2-10mm) in diameter (Fig. 2). During the later stages of infection, the bark falls off the logs.

#### Conditions of occurrence

Direct sunlight is conducive to *Hypoxylon* development. Direct sunlight falling on the bark of shiitake logs can raise the internal temperature to levels which inhibit the shiitake growth, but encourage the growth of *Hypoxylon*.

#### Control measures

- ↳ Do not expose the logs to direct sunlight.
- ↳ *Hypoxylon* levels can be decreased by shading the logs from direct sunlight.
- ↳ Severely infected logs should be removed to lower disease spore concentrations.

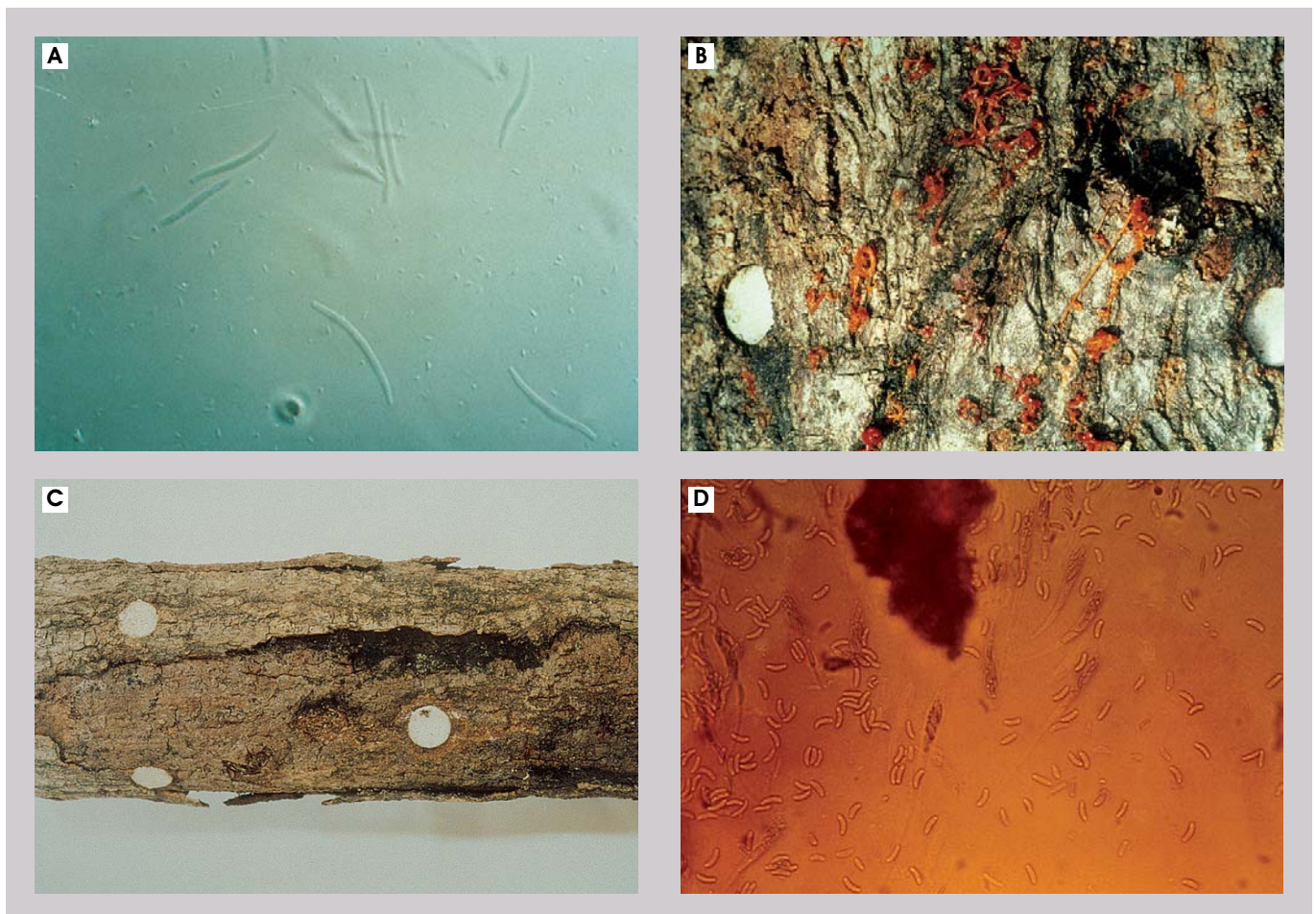
#### *Diatrype stigma* (asexual stage : *Libertella betulina*)

Disease fungus, dry, mid temperature

*Diatrype stigma*, with an associated asexual stage, *Libertella betulina*, which attacks shiitake by secreting anti fungal compounds. Severe infections can also result in total loss of the bark.

#### Morphology and symptoms

During the asexual stage, this fungus produces conidia<sup>2</sup> (Fig. 3A), which enter through cracks in the bark. The conidia in mass are orange and form small hooked curls *ca.* 1/2 inch (1.3cm) in length (Fig. 3B). If the bark is removed, additional spore masses are exposed. At the sexual stage, usually occurring in the autumn months, the fungus forms hard, crusty stromata, which are blackish brown on the surface (Fig. 3C). Dark zone lines are formed between the colonies of the fungus and shiitake (Fig. 3E) and the bark sloughed off (Fig. 3F). The affected logs with their bark removed are subject to secondary contamination by other fungi, such as *Trichoderma* or *Hypocrea*.



<sup>2</sup> conidium : pl. conidia. a small sexual spore, produced vegetatively by special cells on a conidiophore



**Figure 3.** Symptoms and spores of *Diatrype stigma* and *Libertella betulina* **A:** Conidia of asexual stage **B:** Spore horns of *Libertella betulina* **C:** Stromata (sexual stage) formed under the bark **D:** Ascospores of sexual stage **E:** Zone lines between shiitake (a) and *Diatrype* (b) colonies, and spore horns (c) **F:** Debarked log

#### Conditions of occurrence

The fungus usually invades dry logs, especially newly felled logs.

#### Control measures

- ↳ Don't expose logs to dry conditions during felling.
- ↳ Logs heavily attacked by *Libertella* should be removed.

#### Schizophyllum commune

Competitor fungus, dry, mid temperature

This common wild fungus is classified as a medicinal mushroom used in traditional oriental medicine.

#### Morphology and symptoms

The fruiting bodies are leathery, fan-shaped and covered with fine hairs. The fungus is commonly found on dry-spots in logs, particularly second-year shiitake logs. The affected log turns dark brown under the bark.

#### Conditions of occurrence

They are usually found under dry conditions, especially where direct sunlight strikes logs during the hot dry season.

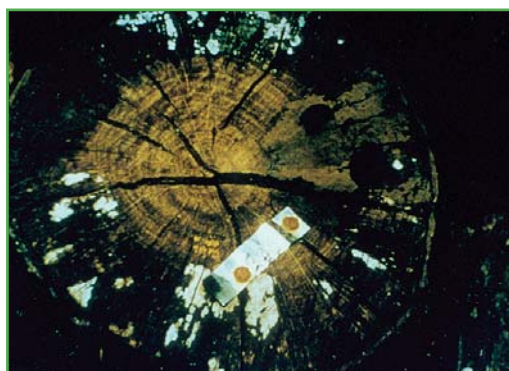
#### Control measures

- ↳ Protect logs against direct sunlight by using shade netting.



**Figure 4.** Fruiting bodies of *Schizophyllum commune*

#### Trichoderma polysporum



**Figure 5.** *Trichoderma polysporum* occurring on the log end

Disease fungus, humid, low temperature

The fungus is associated with *Hypocrea pachybasioides* (sexual stage). It doesn't develop into a green colony, unlike other *Hypocrea* species.

#### Morphology and symptoms

White stromata appear dotted on the log end and turn into light-brown lumps. Colonizing logs rapidly, it eliminates white shiitake mycelia. It builds up large colonies long before it is observed. When the temperature increases, other *Trichoderma* species invade the fungus-infected logs.

#### Condition of occurrence

Humid season with low temperature. This fungus grows best at 20-25 °C, 100% relative humidity, and 65% log moisture content.

### Control measures

- ↳ One of the highest incidences occurs during the snow melting season, when temperatures are low but humidity is high. Do not expose logs to excessive humidity during the snow melt period.
- ↳ Carefully watch logs for any suspicious colonies.

### Bulgaria inquinans

Weed fungus, humid, mid temperature



Figure 6. Fruiting bodies of *Bulgaria inquinans* on the log surface

As a weed fungus, this species decays wood and only competes with shiitake mycelia for space. It presents little problem, and disappears later during the spawn run.

#### Morphology and symptoms

Dark-brown circular fruiting bodies of this fungus change to a black-purple color. These fruiting bodies are soft and rubbery in wet weather and 0.5-4cm wide and 1cm high. Black spots are visible under the bark of the affected logs.

#### Conditions of occurrence

Humid environments with mid temperature.

#### Control measures

- ↳ Inoculate properly dried logs with fast-colonizing, vigorous spawn.

### Coriolus versicolor

Competitor fungus, dry, mid temperature



Figure 7. Fruiting bodies of *Coriolus versicolor*

This fungus is commonly called “Turkey tail,” and is one of the most common fungi found on shiitake logs. It is also classified as a medicinal mushroom used in traditional oriental medicine.

#### Morphology and symptoms

The fungus is thin (1-2mm), leathery, velvety and with alternating bands of dark (black, brown, gray, dark-purple or sometimes greenish) and light color. The underside is covered with whitish pores. As a white rot, it also degrades logs and turns them white, competing with other fungus including shiitake for nutrients and space in the logs. The affected area under the bark might be much wider than where the fruiting bodies appear on the logs. A distinct zone line is formed where *Coriolus* and shiitake mycelia encounter.

#### Conditions of occurrence

This fungus occurs favorably at mid temperatures.

#### Control measures

- ↳ Inoculate the logs in a timely manner in order that the shiitake mycelia can pre-occupy them.

### Stereum sp.

Competitor fungus, dry, mid temperature



Figure 8. Fruiting bodies of *Stereum* sp.

#### Morphology and symptoms

The fruiting bodies of this fungus are red, orange or light to dark brown, fan-shaped, overlapped, and leathery with dense hairs. They are densely appressed against the log surface, with only the margins raised.

As a white rot, *Stereum* quickly degrades logs and forms distinct zone lines in the areas where it encounters shiitake mycelia. The fungus prefers to begin growth on uncolonized parts of the logs.

#### Conditions of occurrence

Half dry, mid temperature conditions

### Control measures

- ↳ Perform timely inoculations in order to allow shiitake to pre-occupy the logs.
- ↳ Keep the cultivation site clean and remove contaminated shiitake logs in order not to infect healthy ones.

## Inonotus xeranticus

Weed fungus, humid, high temperature

### Morphology and symptoms



Figure 9. Fruiting bodies of *Inonotus xeranticus* on the log surface

The fruiting bodies of this fungus are thin, leathery, overlapped, and colored a light gold. Characteristically, numerous, narrow dark brown zone lines (throughout the log when advanced) are observed under the bark. This fungus only competes with shiitake mycelia for log space but mycelial growth of shiitake can be stunted on the affected areas, and this situation might also allow for invasion by other fungi.

### Conditions of occurrence

Growth of this fungus is favored by hot and humid conditions. Insufficiently seasoned logs, logs with a wide diameter, logs in humid conditions are prone to the *Inonotus* infection.

### Control measures

- ↳ Lay and dry logs sufficiently in a well-ventilated site.

## Black-rot disease

Disease fungus, humid, high temperature

Severe damages were reported in Japan and Korea. *Trichoderma harzianum* (sexual stage: *Hypocrea nigricans*) and *Nitschkia confertula* were reported as the causal agents of the black-rot disease in Japan and Korea, respectively.

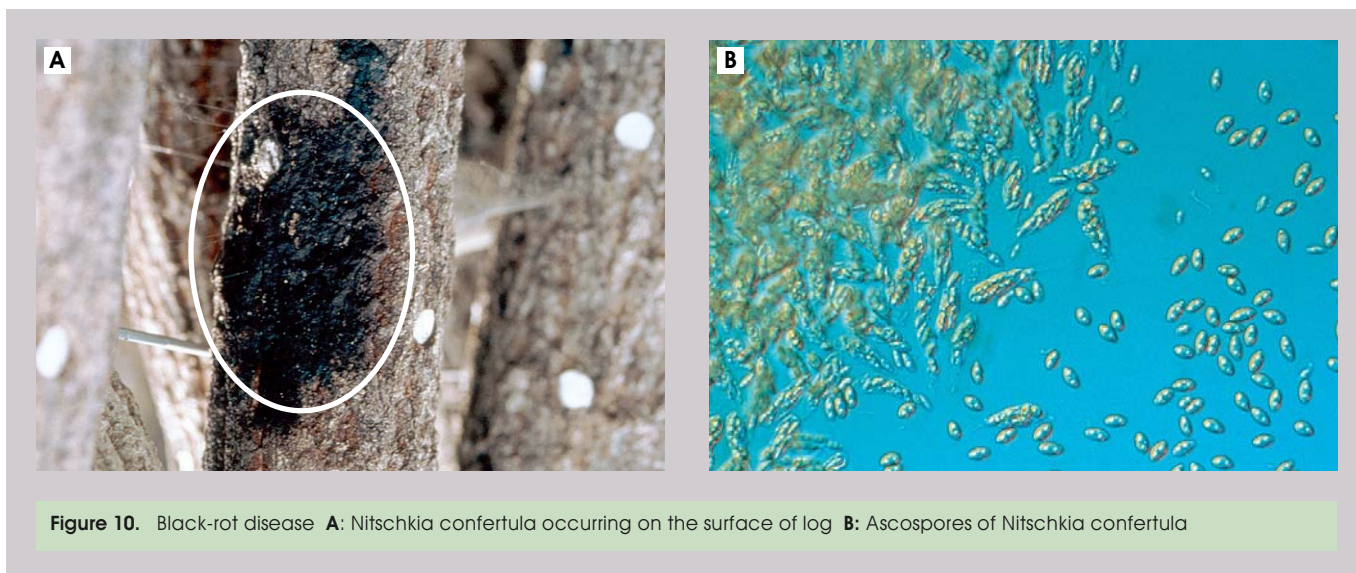


Figure 10. Black-rot disease A: *Nitschkia confertula* occurring on the surface of log B: Ascospores of *Nitschkia confertula*

### Morphology and symptoms

These fungi attack logs and cause black-rot. The bark on affected logs appears as if it were burned (Fig. 10A) and is eventually sloughed off.

### Conditions of occurrence

Serious damage and infestations are reported in poorly ventilated and badly drained log yards during the rainy season. The growth of this fungus is favored by high temperatures and humidity above 80%.

### Control measures

- ↳ Provide good ventilation and remove weeds around the log yard.
- ↳ Avoid humid conditions after rainfall.

### Trichoderma viride

Disease fungus, humid, high temperature

#### Morphology and symptoms

When this fungus occurs the bark of the affected log is peeled off and the exposed log surface becomes a dark brown color. This fungus attacks shiitake mycelia.

#### Conditions of occurrence

Hot and humid conditions

#### Control measures

↳ Avoid high humidity.



Figure 11. Wood surface under the bark attacked by *Trichoderma viride*

## Animal Pests

Insects that might damage cultivated shiitake by affecting logs or the fruiting bodies include termites, beetles, moths, flies and springtails. Slugs and snails are probably the most commonly encountered animal pests of shiitake, and they cause serious damage by feeding directly on the mushroom caps. Shiitake fruiting bodies are unlikely to be free from attack by wild animals when they are cultivated in forest areas or clearings. Other animals that might feed on shiitake fruiting bodies include deer, mice, squirrels, rabbits and pigs.

### Long-horned beetles (Family Cerambycidae)

Freshly inoculated logs

#### Morphology

*Moechotypa diphysis* is a long-horned beetle. The body of an adult of this beetle is black and covered with reddish brown hairs. The length of the body is ca. 16-27mm. The larva is cannon-shaped.



Figure 12. Long-horned beetle A: Surface of log damaged by *Moechotypa diphysis* B: Wooden powder from holes of the affected log C: Adult of *Moechotypa diphysis*

#### Biology

The adults spend winter under the fallen leaves or rotten logs and come out in the following spring. The larvae invade the bark of logs, but avoid the part where shiitake mycelia grow well. As a sign of damage, wooden powder comes out through small holes from the logs.

#### Control measures

↳ Cover logs with an insect net to prohibit the access of adult insects during the oviposition (egg-laying) period.

### Ambrosia beetles (Family Scolytidae)

Freshly inoculated logs

These insects feed on a kind of fungus called "ambrosia" that they introduce when they bore a tunnel into the sapwood and sometimes heartwood<sup>3</sup> of freshly sawn logs. It is the fungus, not the beetle or its larvae, that feeds on and sometimes heartwood of logs wood fiber and grows on the walls of the tunnel. An ambrosia beetle attack can be recognized by the whitish boring dust. Bark beetles on the other hand create reddish boring dust. *Xyleborus validus* is an ambrosia beetle, and is commonly found in a wide range of host trees, including shiitake logs.

<sup>3</sup> For detailed information on sapwood and heartwood, see SHIITAKE LOG CULTIVATION in Chapter 3.



**Figure 13.** Ambrosia beetle **A:** *Xyleborus validus* **B:** Underside of *Xyleborus validus* **C:** Ambrosia beetle-bored hole

### Morphology

The adult insect is cylindrical, shiny black and 3.6-4.0mm long, with spine-like protuberances at the posterior of elytra<sup>4</sup>.

### Biology

The species has one generation per year and overwinters as an adult. Female adults excavate through the heartwood. The tunnels branch in the same plane following an annual ring. The adults spend winter under the bark and come out the following spring in search of a new log or wood to inhabit. Pinholes bored by these beetles provide possible pest fungi with invasion routes.

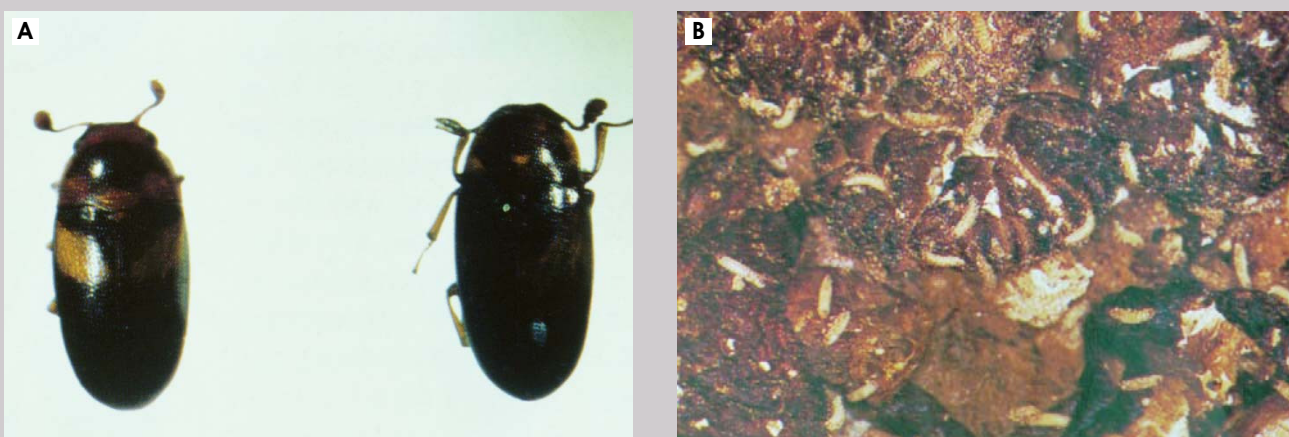
### Control measures

- ↳ Cover the logs with fine-meshed net to keep them free from adult beetles, particularly during their oviposition (egg-laying) period.

### Pleasing fungus beetle (Family Erotylidae)

Fruiting bodies, stored mushroom

As indicated in their common name, pleasing fungus beetles feed on the fruiting bodies of fungi. A wide variety of fungi serve as hosts for the family as a whole, but each pleasing fungus beetle species seems to be specific to a certain group of fungi. For instance, *Megalodacne* spp. feed on *Ganoderma* spp., while *Triplax* spp. feed on oyster mushrooms (*Pleurotus* spp.). *Dacne fungorum* is one of the pleasing fungus beetles that eat shiitake. Some *Dacne* bore into the stems of plants or wood rather than feed on fungi. *Dacne* is a genus of small beetle of the family Erotylidae. Most species in this widely distributed family are tropical.



**Figure 14.** Pleasing fungus beetle **A:** *Dacne fungorum* **B:** Larvae in shiitake in storage (Photo courtesy of Furugawa and Nobuchi)

<sup>4</sup> elytra: sg. elytron. modified, hardened forewings of certain insect orders, notably beetles (Coleoptera) and true bugs (Hemiptera)

### Morphology

The adult bodies are colored a shiny reddish-brown. The fore wings have a V-shape stripe. The length of an adult is *ca.* 3-4.5mm. Important structural characters include their clubbed antenna, and lack of pubescence (fine hairs). *Dacne* is one of the smallest pleasing fungus beetles. The body shape is usually elongate-oval or egg-shaped.

### Biology

Adult insects appear in summer and autumn. They lay eggs 3mm deep from the surface of fruiting bodies. The larvae penetrate into the fruiting bodies and cause damage.

### Control measures

- ▷ Be careful not to delay the harvest of fruiting bodies. Avoid high temperature and humidity in the fruiting site.
- ▷ For storage, heat dry the fruiting bodies. Install filter-equipped ventilation units at windows.
- ▷ Dispose of spent logs or contaminated fruiting bodies.

### Moths

Stored mushrooms

As its common name, the European grain moth, implies, *Nemapogon granellus* is a major pest that causes great damage to stored grains and vegetable products. The moth is found all over the world and also known as the corn moth, and the wine cork moth, because it ruins bottled wine by burrowing into the corks.



Figure 15. Adult and larva (bottom) of *Nemapogon granellus*

### Morphology

The adult body has a wingspread of about 15mm. The fore wings are mottled with grayish white and dark brown spots. The hind wings are dark gray and fringed with long hairs. An adult has a yellowish white body 7mm long and a red-brown haired head.

### Life cycle

Adults lay eggs in the gills of shiitake pileus. They overwinter as larvae that feed on stored shiitake. An infestation is often discovered when the full grown larvae leave their food source and crawl around to find locations appropriate for pupation. The pupae are often found on the gills of fruiting bodies. The adult moth appears in 2 generations annually. The larvae invade fruiting bodies.

### Control measures

- ▷ Fumigate affected fruiting bodies with powdered gypsum or subject them to smoke or fumes in order to exterminate pests and disinfect the crop.
- ▷ Eliminate, cook, freeze or place in air-tight containers all potential sources of food for the moths and employ smoke or fumes in order to exterminate and disinfect the growing area.
- ▷ Heat-dry harvested fruiting bodies in a dryer at 50°C for storage and preserve them in sealed bags in a refrigerator.
- ▷ Set up poisonless moth traps.

### Slugs

Fruiting bodies



Figure 16. *Philomycus confusa* eating gills of shiitake

Slugs and snails are among the most serious pests of shiitake cultivated on logs. They are a problem primarily in moist climates. The smaller slugs can build up to high levels before they are noticed. Slugs are widely spread all over the world and damage fruiting bodies by gnawing at them. Slugs inhabit a wide variety of garden plants, forest plants, and particularly cabbage plants. Slugs are found when the ground thaws in the spring until it freezes in the fall. Wet conditions are ideal for slug development.

### Morphology

Slugs resemble snails without shells. They have two antennae on their heads and three dark-brown stripes. The bodies are brown, soft, slimy and about 6cm long.

**Life cycle**

Slug eggs are gelatinous, spherical, and filled with a watery substance. They range from 0.3-0.6cm in diameter. They are usually colorless, often reflecting the color of their surroundings. They become cloudy just before hatching. Eggs are laid in moist areas. Young slugs resemble adults in shape but are smaller and light colored. They become adults after about 5 months.

**Control measures**

- ↳ Remove them as they appear, usually after a rain-fall.
- ↳ Install filter-installed ventilation units at windows.
- ↳ Carefully and regularly watch log yards for early detection of slugs.
- ↳ Lure them away with vegetables like cabbage (decoying) and collect and destroy them.
- ↳ Eliminate their shelters.
- ↳ Sprinkle lime and wood ash around stacked logs, put a layer of gravel on the ground around the stacks, remove all dead leaves and other organic debris, and keep the soil surface dry.
- ↳ Spread gravel under the fruiting logs, keep vegetation low so that the ground stays dry, and use slug and snail bait.

**Mammals****Fruiting bodies**

A wide range of wild and domestic animals including mice, squirrels, deer, rabbits, ducks, geese and pigs feed on shiitake. Some animals are known to be fond of shiitake or to store it as food for winter. In order to discourage them, farmers should identify their pests and then study their behavior and preferences in order to determine the best control strategy for the farm. Fences, barriers and repellants are commonly used.

## Part I Shiitake

## Chapter 5

Pest and Disease Management of Shiitake**PEST AND DISEASE MANAGEMENT  
IN SHIITAKE BAG CULTIVATION**Leifa Fan<sup>1</sup>, Huijuan Pan<sup>1</sup>, Yingmei Wu<sup>2</sup> and Hyunjong Kwon (Miji)<sup>3</sup><sup>1</sup>Horticultural Institute, Zhejiang Academy of Agricultural Sciences, Hangzhou, 310021, P.R. China \*(fanleifa@yahoo.com.cn)<sup>2</sup>Zhejiang Qingyuan Nature Co., Ltd., P. R. China<sup>3</sup>MushWorld, Korea

Many pests and diseases can occur during bag cultivation of shiitake, because the pests also thrive in warm and humid conditions as they feed on the nutrients in the substrate. If unnoticed, these pests often lower productivity and quality and can sometimes cause total crop failure. The use of pesticide chemicals, however, is not advisable, as these materials can affect the mycelial growth and reduce the quality of the shiitake. These pesticides are also strictly regulated in most countries. As a result, for mushroom growers, energetic precautionary measures should be taken to avoid contamination. Good sanitation and hygienic practices during all stages of cultivation are the keys to successful pest and disease management.

**The Basic Preventive Measures**

1. Select fresh, pathogen and pest-free substrates and supplements.
2. Eliminate pathogens (spores) and pests (eggs) of shiitake bag by strict sterilization or autoclaving.
3. Clean and disinfect the inoculation room and box (Figs. 1 and 2).
4. Keep hands and tools clean during spawning.
5. Keep the incubation room clean and well-aerated.
6. Timely and carefully inspect the bags and eliminate contaminated bags immediately. Before disposal, sterilize the contaminated bags by autoclave.
7. After harvest, remove shiitake stumps or debris, which might attract pests.
8. Disinfect the spent substrate and shiitake houses, and other materials on a regular basis.
9. Wear clean clothes and shoes all the time (Fig. 3) and wash hands before manual work.



Figure 1. Inoculation box



Figure 2. Alcohol for disinfection during inoculation



Figure 3. Clean clothes during work



Figure 4. Raw material next to contaminated synthetic logs

## Fungal Diseases in Shiitake Bag Cultivation

### Green mold (*Trichoderma* spp.)

There are many species and strains of the species, such as *T. viride*, *T. koningii*, *T. polysporum*, *T. longibrachiatum* and *T. glaucum*, of which, first two are principal species during shiitake bag cultivation.

*T. viride* is characterized by dense white mycelial growth (Fig. 5) followed by extensive green sporulation of the fungus (Fig. 6). An apparently normal shiitake spawn run may give way to large patches of green *Trichoderma* sporulation. A browning reaction may occur, or the fruiting bodies may be covered with green mold.

The pathogenic fungus appears to gain entry to growing rooms primarily through contaminated spent mushroom substrate (Fig. 4), personnel and equipment. Other sources include poorly sterilized substrate or poorly disinfected transfer between growing rooms. Once introduced into substrate the fungus rapidly spreads into large patches, interacting with the shiitake mycelia. At the advancing edge of the green mold patches, browning of shiitake mycelia or lysis<sup>1</sup> of small pins is visible macroscopically, suggesting enzymatic degradation. Microscopic investigations have shown mycelial collapse and cellular disorganization. Infestation by green mold results in green sporulation and darkened patches (Fig. 8), which in turn cannot be colonized by shiitake mycelia. When colonized by shiitake mycelia, those patches will produce much lower yields of inferior quality shiitake. The shiitake fruiting bodies may become soft after infection, and may produce black liquid. *T. koningii* is also reported, and it is difficult to distinguish whether a problem is caused by *T. viride* or *T. koningii*. These *Trichoderma* infestations are usually found in poorly sterilized substrates when the environmental humidity is high.



Figure 5. Overwhelmingly infested synthetic log by extensive white mycelial growth



Figure 6. Synthetic log covered by green spores from green mold

<sup>1</sup> lysis: dissolution or destruction of cells by the action of a specific substance that disrupts the cell membrane



Figure 7. Inside the synthetic log well-colonized by shiitake



Figure 8. Inside the synthetic log infected by green mold

### Control measures

- Do not use green-mold contaminated spawn (Fig. 9).
- Sterilize substrate bags thoroughly.
- Use good sanitation and hygiene and disinfect equipment regularly.
- Avoid high humidity and high temperature in the shiitake house.
- Remove or treat spots with white, dense mycelial growth indicating green mold fungi.
- Remove contaminated bags immediately.



Figure 9. Spawn infected by green mold

### Red bread mold (*Neurospora sitophila* and *N. crassa*)

Symptoms of red bread mold infestation are similar to those of green mold. The fungus is characterized by white mycelial growth, but followed by extensive red or orange sporulation. The pathogens invade particularly poorly sterilized or highly moistened substrate. Being readily air-borne, it rapidly spreads to be epidemic, when the room temperature and humidity are relatively high. A synthetic log with the plastic bag removed is quite prone to contamination, which might result in primordia malformations.



Figure 10. Substrate bag infected with red bread mold



Figure 11. Infected bags removed from the growing house

### Control measures

- In order to prevent pathogenic spores from being dispersed in the growing room, apply limestone powder to the affected part of substrate bag and get the bag out of growing room. Remove plastic and bury the contaminated synthetic log in the ground.
- Do not spray any treatment solutions.

- Remove and treat contaminated synthetic logs in the same way as in control for green mold.

### Blue mold (*Penicillium* spp.)

Blue mold is a lesser threat than green mold. There are many species reported, such as *P. citrinum*, *P. funiculosum*, *P. chrysogenum*, *P. cyclopium*, *P. pallidum*, *P. digitatum* and *P. italicum*. The initial symptoms of blue mold are also similar to those of green mold. The blue mold colony shows white mycelial growth first and extensive blue sporulation of the fungus. The colony spreads slowly in comparison with that of green mold. This mold favors acidic substrates.

#### Control measure

- Ventilate the shiitake house to decrease the relative humidity.
- Treat the diseased area with 5-10% limewater solution and cover it with a wet cloth to prevent the disease spores from spreading.

### *Mucor* spp.

These fungi are commonly found in soil, air, manure, old stale straw and compost. They are characterized by rapid growing colonies, which are cottony and thick owing to abundant upright sporangiophores<sup>2</sup>, white at first, olive gray to brown but white on the underside of the petri dish. Spores are brownish. *Mucor* has a higher growth rate than shiitake mycelia. This fungus can occupy substrate, which has the effect of stunting the growth of shiitake mycelia causing them to turn yellow.

#### Control measures

- Ventilate the shiitake house to decrease the relative humidity.
- Do not use stale substrate materials.
- Spray limestone on the sides of the shiitake house.
- Inject 5-10% solution of ammonium bicarbonate (NH<sub>4</sub>HCO<sub>3</sub>) into the diseased areas.

### *Aspergillus* spp.

These fungi are recognized by their distinct conidiophores<sup>3</sup> that terminate in a swollen vesicle bearing flask-shaped phialides<sup>4</sup>. The colony is white at first and becomes yellow green, usually thick owing to abundant conidiospores<sup>5</sup>. The fungus is widely found in soil, air and organic litters and highly likely to appear in a humid, poorly ventilated shiitake house.

#### Control measures

- Stop watering and ventilate the shiitake house to decrease room humidity.
- Spray a 1 : 500 solution of Carbendazol (carbendazim) on the affected area.

## Pests in Shiitake Bag Cultivation

### Mites

Among the many species of mites, the two mite types in particular that cause damage to shiitake are the pyemotid mite (Siteroptes) and the acarid mite or flour mite (Acarides). The pyemotid mite is small and invisible to the naked eye, brownish when seen in groups on the substrate, while the acarid mite is large, white, and looks like flour when present in large quantities. They both feed on shiitake mycelia and fruiting bodies, lowering mushroom quality and yield.

#### Control measures

- Clean the substrate storehouse.
- Maintain sanitation practices and general hygiene and disinfection during all stages of cultivation.
- Perform substrate preparation and bag filling away from the cultivation houses.

### Springtail

Springtails are tiny soft-bodied invertebrates, mostly less than 10mm in length. They are most distinguished by their small forked tail-like organ on the underside of their abdomen, which enables them to leap away when disturbed. The principal species is purple springtail, *Hypogastrura communis*. They usually hide in the damp corners and feed on shiitake mycelia and fruiting bodies. Sometimes springtails aggregate sufficiently to form visible masses on the substrate. Springtails cause yield lowering and a decrease in quality.

<sup>2</sup> sporangiophore: a specialized branch bearing one or more sporangia

<sup>3</sup> conidiophore: a specialized fungal hypha that produces conidia

<sup>4</sup> phialide: a particular type of flask-shaped cell that gives rise to conidia (conidiospores)

<sup>5</sup> conidiospore: an asexually produced fungal spore formed on a conidiophore (syn. conidium)

### Control measures

- Clean the substrate storehouse and shiitake cultivation houses.
- Maintain sanitation practices and general hygiene and disinfection during all stages of cultivation.
- Build the shiitake cultivation houses separate from the substrate storehouse and other buildings and dwellings.
- Spray a solution of limewater in the shiitake houses before cultivation.

### Slugs

Several species of slugs frequently damage shiitake fruiting bodies, including the wild slug (*Agriolimax agrestis*), the phagus slug (*Philomycus bilineatus*) and the yellow slug (*Limax flavus*). They are active at night and during cloudy or foggy days when they can easily hide themselves in humid shade.

### Control measures

A good slug management program relies on a combination of practices. The first step is to eliminate slugs' daytime sheltering locations such as plant debris, weeds, and stones around the shiitake cultivation houses. Trapping and handpicking on a regular basis contributes to integrated slug control. By using a flashlight, growers can detect slugs in the dark and picked slugs can be put in a bucket with soap, salt, or a limestone solution.

## Further Reading

### Shiitake Abnormalities

Mushrooms can be malformed under unfavorable conditions. Like competitor or weed fungi, abnormal mushrooms only consume nutrients in the synthetic log or occupy space without bearing any substantial fruit. Most cases of malformed mushrooms can be prevented by cultural management-temperature and humidity control at a given stage. Common shiitake abnormalities and their respective, possible occurrence conditions are as follows.

- ✧ Low/high temperature or humidity here indicates lower/higher temperature or humidity than required for the growth of a given shiitake strain. Generally, shiitake develops fruiting bodies at 10-20 °C and 75-90% R.H..

#### Double cap



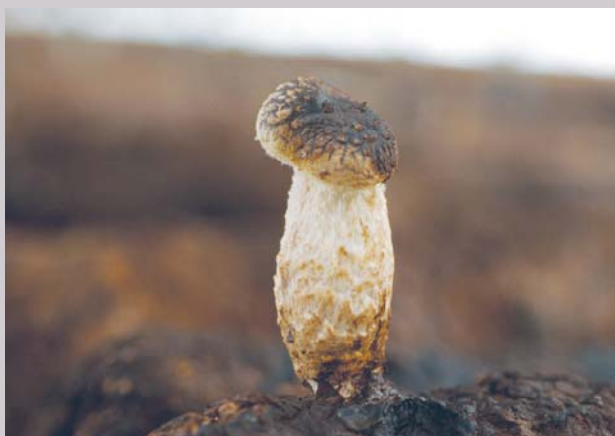
Figure 12. Double capped shiitake

#### Cracked cap



Figure 13. Fruiting body with cracked cap

Another pin may form on the cap (Fig. 12) if a fruiting body develops under low temperature around 5 °C and/or if the synthetic log where it develops has high moisture content. Cracking of cap surface (Fig. 13) is caused by the low temperature and low humidity during fruiting body development. This characteristic condition of fruiting body happens when inner part of cap outgrows outer part. Ironically, cracked fruiting bodies are priced at much higher than the normal, uncracked ones.

**Enlongated stipe with small cap**

**Figure 14.** Fruiting body with enlongated stipe and small cap

**Swollen stipe**

**Figure 15.** Swollen stipe

Enlongation of stipe (Fig. 14) usually occurs when the pin formation is excessively delayed, when fruiting room lacks lighting, when the synthetic log lacks nutrients, or growing temperature is higher than the optimal temperature condition at fruiting body development. Swelling of stipe in developing fruiting bodies (Fig. 15) occurs when pinning and subsequent fruiting body development is performed at lower temperatures. Immature pin formation at low temperatures may cause stipe to grow thick.

**Darkened cap**

**Figure 16.** Fruiting bodies with darkened cap

**Pale fruiting body**

**Figure 17.** Pale fruiting body

Surface of cap can be darkly pigmented (Fig. 16) when there is an extremely high humidity and low temperature as well as heavy watering on young or half-grown fruiting bodies. Pale fruiting body (Fig. 17) may be caused by dark conditions at fruiting body development .

Fruiting body without gills

**Figure 18.** Fruiting body without gills

Small fruiting body

**Figure 19.** Small fruiting bodies

This deformed condition shown in Figure 18 can be caused when fruiting is induced before the synthetic log is fully colonized by the shiitake mycelium. Reduced size of fruiting body (Fig. 19) can be caused by the low temperature, abrupt decrease in humidity during the development of fruiting body, and lack of enough nutrient and moisture in the synthetic log.

## Part I Shiitake

## Chapter 6

Shiitake Growing House**SHIITAKE GROWING HOUSES-KOREAN CASES**

Kyung Wha Choi (Ivy)\* and Seungwoo Kang (Richard)

MushWorld, 150-5 Pyungchang, Jongro, Seoul, Korea \*(kwchoi@mushworld.com)

**Climatic Environment and Growing House****Figure 1.** Seasonal winds in Korea

Korea has four distinct seasons; spring, summer, autumn, and winter. Mountainous regions make up about 65% of the national territory. Although Korea has various regional climates, its general climate is affected by the Siberian air mass and the Northern Pacific air mass (Fig. 1). The Siberian air mass brings cold and dry winds from the northwest in winter while the Northern Pacific air mass brings hot and humid winds from the southeast during summer. Dry and warm spring weather sometimes sees the yellow sandy dust phenomena for several days due to the wind-blown loess from North China. The Okhotsk Sea air mass meets the Northern Pacific in late spring and early summer. Together these two air masses make a rain front on their contact surface, and this produces a rainy spell that lasts from late June to mid July. This rain front moves from south to north as the Northern Pacific high pressure gets stronger. This subtropical high then causes a hot and humid summer that starts in late July. Sometimes the equatorial air mass can cause typhoons during the summer.

The Korean climate affects the design and construction of their shiitake growing houses. In general, shiitake growing houses are more easily affected by the outside environment, in contrast to many other mushroom cultivation houses that are typically quite insulated from outside influences. Shiitake growing houses aligned in a north to south direction take advantage of the seasonal winds in winter and summer. Doors are closed in winter to exclude the cold and dry northwestern wind and the doors are opened in summer to take advantage of the humid southeastern wind. The north-south alignment of the growing houses exposes shiitake logs or bags to relatively uniform amounts of sunlight within the different parts of the growing houses. If the growing houses are built in an east-west alignment, because Korea is located in the northern hemisphere, the bags or logs in the southern parts of the growing houses would receive full sunlight, and as a result a temperature gap would occur between the northern and southern parts within the growing houses.

A good water drainage system is very important. In particular, the hot and humid summers experience 70% of the annual rainfall. Summer usually includes one solid rainy month, and quite a few typhoons. The center of a growing house floor is a bit raised and drainage canals surround the structure. Gravel on the floor is very helpful for water control as well. Korean summers are quite hot, and the temperature reaches 32°C, so shading nets are used to block the sun. The density of the shading nets varies from 50 to 100%. Air filtration is needed in spring due to the yellow sandy dust phenomena, and roofs and

walls must be cleaned by washing with water.

There are several kinds of shiitake growing houses in Korea, and they vary according to the extent of environmental control possible, cultivation methods, and the structure of the growing houses. Among them, ordinary growing house and overlapping open roof growing house will be examined. Detailed construction process and management for overlapping open roof one are also provided.

## Ordinary Growing Houses

### Log cultivation

Shiitake log cultivation does not require many environmental controls. Spawn run and fruiting induction can be done outdoors under trees in the forest. A simple structure is sufficient for screening direct sunlight and offering protection from rain and snow. Such minimal control is possible because the bark on the logs themselves provides good protection for the inoculated shiitake mycelia. However, the logs do require seasonal management. During the dry springs, the stacks of inoculated logs are protected under plastic covers to prevent excessive drying (Fig. 2A). Later, as the spawn run continues within the logs, the plastic covers are removed and shading nets are mounted to protect the logs from direct sunlight (Fig. 2B). Much attention is paid to preventing the logs from getting wet during the rainy spell and severe rainstorm of summers.



**Figure 2.** Log cultivation **A:** Logs covered with plastic sheet after inoculation **B:** Shading nets **C:** Logs in growing house

Sometimes, the logs are placed within a fully equipped growing house effective for sun screening and ventilation (Fig. 2C). Sometimes, watering nozzles are attached under the roof. Although this increased protection allows a higher productivity and quality, production costs also increase. Nonetheless, quite a few growers are now using these more expensive growing houses because the price gap between the lowest and the highest quality can often be a factor of 10 times and this allows growers to target much larger profits with only a slightly larger investment.

### Bag cultivation

Bag cultivation requires a great deal of cares, so bags are cultivated exclusively in well controlled growing houses. The inoculated

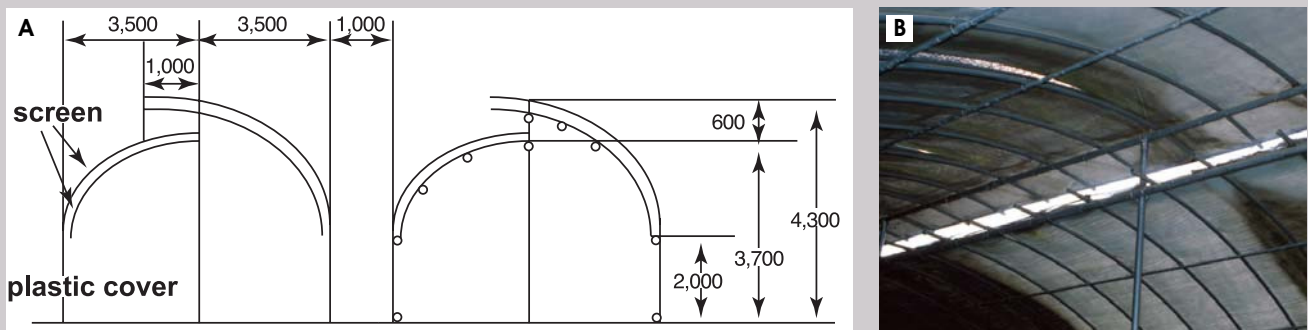


**Figure 3.** Bag cultivation in growing house **A:** Fruiting on the floor **B:** Fruiting on shelves

bags are colonized by shiitake mycelia in an incubation room or in the growing house. When the spawn run is complete, the bags are spread on the floor or on the shelves of a growing room (Figs. 3). Temperature and humidity is controlled mostly by ventilation and the side walls can be rolled up and down to control the environment inside the houses. (Fig. 3A).

### Overlapping Open Roof Growing House

Shiitake prefer a temperate climate, so it is difficult to cultivate them during hot summers. The biggest problem for Korean shiitake growers is lowering the temperature in summer. The overlapping open roof house is a design that has been modified in order to allow growers to efficiently control the growing environment in the hot and humid Korean summers by promoting more ventilation through the open roofs. This house style is very effective and the construction cost is not much higher than a regular greenhouse. The basic structure permits growers to make use of the external environment rather than attempting to artificially control it. Warm air moves upward within the growing house, then it naturally goes out through the opening on the roof and the empty space is filled with outside air coming in through the open side walls or side wall shading nets. Though its arch roof is opened to outside air, the overlapping section protects the inner space from rain and snow (Fig. 4A). Cold wind and storms can be effectively blocked by covering the roof with a plastic cover. It is recommended that the open section face away from the direction of prevailing winds and storms. This type of growing house can be used both for log cultivation and bag cultivation and is available in every season, but is especially useful during hot summers.



**Figure 4.** Overlapping open roof house **A:** A plan of overlapping open roof house **B:** The overlapping open roof seen from inside growing house

### Construction model of an overlapping open roof growing house



**Figure 5.** Inner structure **A:** Inner structure of plastic film **B:** Windshield against cold wind in winter

This example is a threefold structure using an overlapping open roof house, and allows for more effective growing house management. This growing house consists of 1; the inner structure of plastic film, 2; the outer structure with an overlapping

open roof, and 3; the outside shading nets.

The inner structure consists of a simple construction and plastic cover of 0.1mm in thickness (Fig. 5A). The plastic cover of both the arch roof and the side walls can be rolled up and down by controlling winches. A plastic windshield covers the side wall from the bottom up to a height of 50cm in order to block the cold wind in winter (Fig. 5B). Cold air is heavier than warm air, so it is usually on the bottom, so this windshield is effective at preventing cold wind from coming into the growing house.

The outer structure has an overlapping open roof (Fig. 6A) that fully covers the inner structure. There is a space about 50cm wide between the inner and the outer structure. The outer structure is covered with two sheets of plastic that cover a sheet of cashmilon in the middle. White cashmilon maintains interior and is good for light transmission. The open roof can be closed with a winch.



Figure 6. A: Outer structure and shading net B: Shading net rolled up

The outside shading net protects the growing house from direct sunlight. This particular structure does not have side walls or doors, but only has a roof with shading nets. The shading net can be rolled up and down by winch. (Figs. 6). The density of shading net varies from 50-100% and Figure 6A shows shading nets with a 90% density.

### Construction step 1: making framework

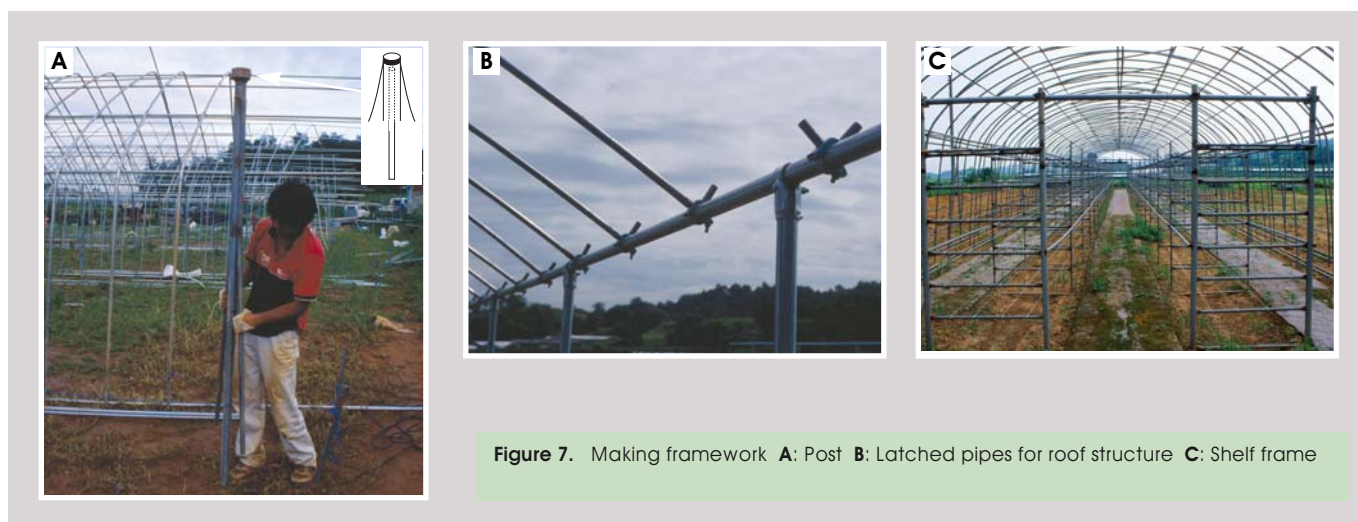


Figure 7. Making framework A: Post B: Latched pipes for roof structure C: Shelf frame

All the obstacles are removed on the selected location and the ground is leveled. The first work is to set up the posts of the side wall (Fig. 7A). Posts can be hammered into the ground with the tool shown in the circle (Fig. 7A). The roof pipes are bent to more than 30 degrees to prepare for heavy snowfall in winter. The high angle will prevent snow from accumulating on the roof. The roof pipes are connected with a pipe on the side wall posts (Fig. 7B). All the pipes for the framework are



### Construction step 2: plastic cover and shading nets



Figure 9. Plastic sheet of inner structure rolled up

**Inner structure:** The interior structure is under the protection of outer structure, so the 0.1mm plastic film is sufficient. Two sets of winches are installed on the inner structure. One is for controlling the arch roof and the other is for raising and lowering the side walls (Fig. 8A). Figure 9 shows the plastic film of the inner structure fully rolled up on the arch roof.

**Outer structure:** The outer structure consists of two sheets of 0.1mm plastic film and 8 ounce cashmilon. A winch is equipped on side wall to roll up the outer layer up to where side wall meets the arch roof (Fig. 8B). The most important structure is the open roof section of the outer structure. In order to prevent damage to the plastic and shade netting from repeated rolling up and down, two protective pads are attached to each structure of the culture house as shown in Figure 10C.

**Outside shading nets:** Shading net blocking 90% light is used, and this is attached only to the top part of the frame in order to be able to roll up the net (Fig. 8C).



Figure 10. Roof of outer structure **A:** Framework of open roof part **B:** Overlapping open roof covered with plastic films and cashmilon, and the structure for shading net above it **C:** Sketch of open roof part

### Construction step 3: equipment and the floor

Once the structure is erect and covered, the various doors, ducts, boilers and drainage systems are installed. A radiator that uses underground water with a year round constant temperature is employed for cooling and heating in summer and winter. The aisles are covered with cloths for water control and the floor is raised below the shelf frames in order to prevent water puddling and ensure adequate water drainage.



Figure 11. Growing houses with threefold structure under construction **A:** Completed framework **B:** Completed covering with plastic films and shading nets

## Growing House Management

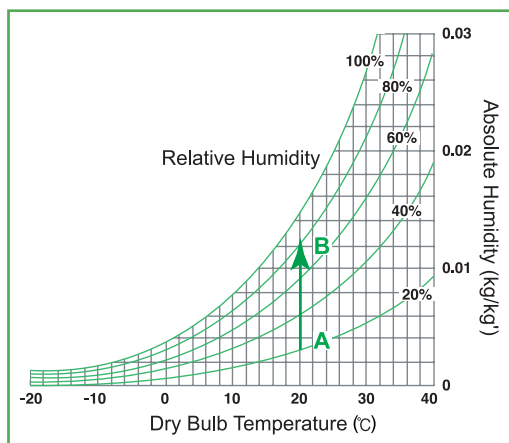


Figure 12. Psychrometric chart

Environmental management of a growing house aims to provide an appropriate environment for shiitake production. The psychrometric chart shown here (Fig. 12) shows relative humidity and absolute humidity relevant to the changing temperatures.

For example, if a farmer wants to adjust the current state A (20 °C temp., 20% R.H.) to B (20 °C temp., 80% R.H.) in Figure 12, they can see from the chart that absolute humidity is 0.003 now, but when 80% R.H. the absolute humidity is 0.012. So, assuming the volume of growing house is 1,000m<sup>3</sup>,  $(0.012 - 0.003) \times 1000 = 9$ , which means we have to vaporize 9kg water into humidity and introduce this into the house.

### Temperature

The key point of temperature control is cooling in the summer. Unfolding the shading net will block the sunlight. The outer structure can be rolled up to the shoulder of the house, and the inner structure can be opened to the top for efficient ventilation. The roof of the outer structure can also be opened to let the rising hot air be sucked up for the release to outside. When the air temperature goes up over 30 °C, the underground water with a constant temperature of 15 °C is sprayed and the inside temperature can be lowered by 3 °C. In winter, the overlapping roof can be closed, the shading net folded and all the side walls closed. When necessary, a boiler can be operated to blow warm air into the house (Fig. 13A).

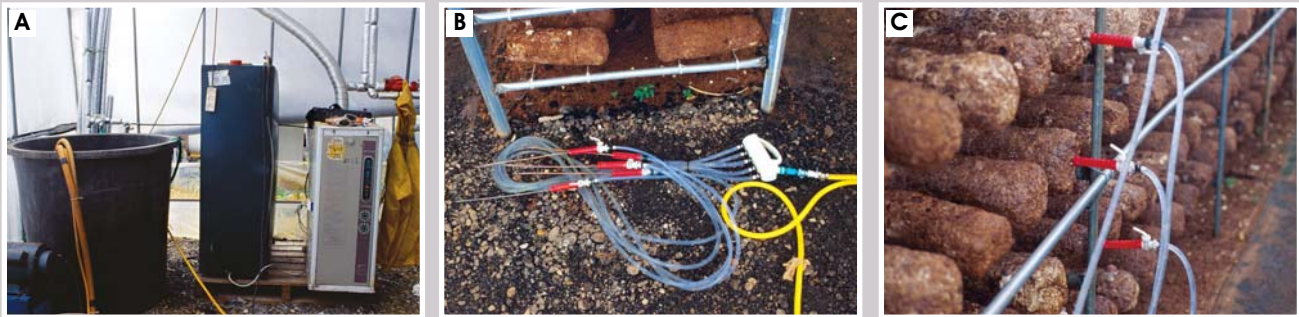


Figure 13. Equipments for environmental management A: Boiler B: Duct

### Watering and ventilation

Watering inside the house creates enough humidity to the growing house as well as lowering the temperature. Ventilation is required after watering in order to dry the wet surfaces of the bags. In the rainy season (late June to mid July) with a 100% relative humidity, green mold is more likely to attack shiitake bags, so forced ventilation is used to blowing dry cool air inside the house.

Ventilation also provides fresh air for mycelial growth and fruiting. To produce flower shiitake, growers need to inject sufficient water into the substrate while lowering the relative humidity inside the growing house. A water injection kit is very useful for injecting water into the shiitake substrate (Figs. 14).



**Figure 14.** Equipments for watering-water injection kits **A:** Water tank **B:** Water distributor **C:** Needles

## REFERENCES

- Cho, Songbaek. 2004. Shiitake growing house for sawdust bag cultivation. MushWorld website. available at [http://kr.mushworld.com:1507/tech/view.asp?cata\\_id=1400&vid=6489](http://kr.mushworld.com:1507/tech/view.asp?cata_id=1400&vid=6489) (in Korean)
- Kang, Seungwoo. 2003. A case study of air conditioning - cooling. MushWorld website. available at [http://www.mushworld.com:1508/tech/view.asp?cata\\_id=1290&vid=5752](http://www.mushworld.com:1508/tech/view.asp?cata_id=1290&vid=5752)
- Office of the Prime Minister - Geography and People page available at [http://www.opm.go.kr/warp/webapp/content/view?meta\\_id=english&id=29](http://www.opm.go.kr/warp/webapp/content/view?meta_id=english&id=29)
- Park, Sangdon. 2001. Growing house for shiitake cultivation. MushWorld website. available at [http://www.mushworld.com:1508/tech/view.asp?cata\\_id=1120&vid=317](http://www.mushworld.com:1508/tech/view.asp?cata_id=1120&vid=317)
- Yoo, Kunho. 2000. Model of shiitake growing house. MushWorld website. available at [http://kr.mushworld.com:1507/tech/view.asp?cata\\_id=1120&vid=896](http://kr.mushworld.com:1507/tech/view.asp?cata_id=1120&vid=896) (in Korean)

## Part I Shiitake

## Chapter 7

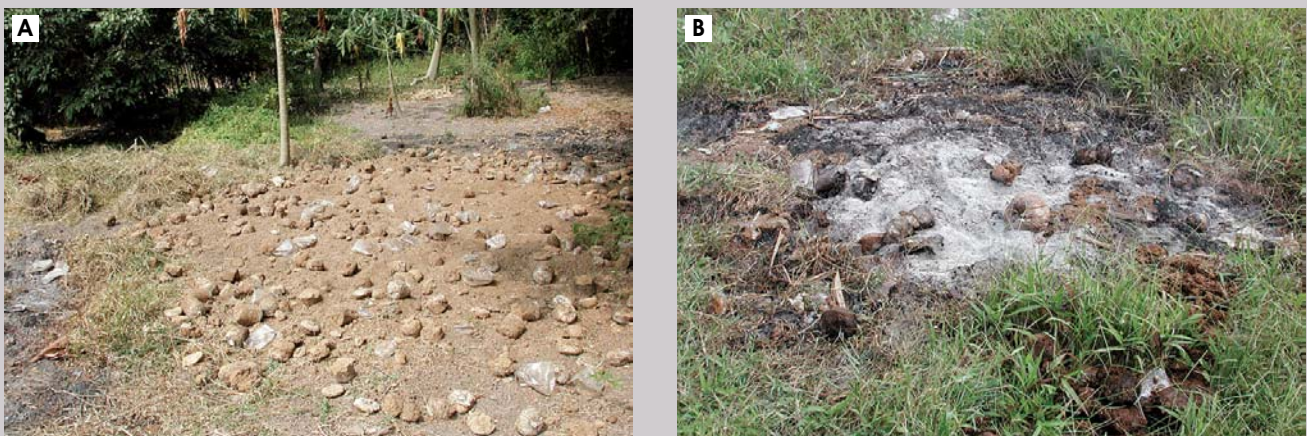
Shiitake Post Harvest**RECYCLING SPENT SHIITAKE SUBSTRATE**

Danny Lee Rinker

Department of Plant Agriculture, University of Guelph, 4890 Victoria Avenue, PO Box 7000,  
Vineland Station, ON L0R 2E0 Canada (DRinker@UoGuelph.Ca)

In the production of any and all species, significant residual material remains after cultivation. Every tonne of mushrooms produced results in one to two tonnes of dry spent residual material. The important question in this day of limited natural resources and concerns over human health and the environment is, "What use or value does this residual material from mushroom production have?"

Shiitake, *Lentinula edodes*, represented 25% of the 1997 world mushroom production (Chang, 1999). This species is either cultivated on natural logs or on a "synthetic" logs. Natural log production utilizes various species of trees, especially oak. Trees are cut down after leaf fall and the wood is cut in lengths of about one meter. Within one month these logs may be inoculated with the shiitake fungus. After up to one year of incubation, the colonized logs are brought under conditions that initiate fructification. Mushrooms are harvested about twice per year for several years. Once production ceases, these logs are considered as spent. "Synthetic" logs for production of shiitake mushrooms are formed from sawdust, straw, corncobs or mixtures of these. Starch-based additives from cereals are often added to optimize the nutritional needs of the fungus. The growing materials are generally sterilized. After colonization is completed, environmental conditions are changed to initiate the formation of mushrooms. After several harvests, these synthetic logs are considered spent. Unfortunately, many growers discard the spent shiitake substrate (SSS) near the production rooms (Fig. 1A) or burn them as refuse (Fig. 1B). The discarded SSS is a repository and breeding area for diseases and insects near the mushroom farm. These pests may easily re-infest and contaminate growing materials and healthy new mushroom crops. Furthermore, the leachate from discarded SSS may enter surface waters, thereby polluting them. Burning the SSS pollutes the air, affecting not only its quality but also the usefulness of the surrounding area for living or recreation. The plastic bags used to hold the sawdust media can be problematic to the



**Figure 1.** Spent shiitake substrate was emptied from the growing rooms and discarded into a field near the mushroom facility (A). Discarded spent shiitake substrate was burned after the mushroom crop was finished (B).

environment in their disposal. There are very few published articles that discuss the re-use of spent shiitake mushroom substrate. The following brief comments reference either published literature or personal communications in the re-use of spent shiitake substrate. Its reported uses are diverse but its documentation is sparse.

**1. Purification of water.** Shiitake spent substrate has been used in the purification of water. Chang *et al.* (2000) reported its use in the treatment of acid mine drainage and D'Annibale *et al.* (1998) the treatment of effluents from olive mills.

**2. Purification of soil.** *Lentinula edodes* spent substrate has been used to remove and degrade pentachlorophenol (PCP) (Okeke *et al.*, 1993; Chiu *et al.*, 1998).

**3. Food crops.** Production of horticultural crops has been enhanced through the spent shiitake substrate being crushed (Fig. 2) or pelletized into an organic fertilizer (Clifford Keil, USA, pers. com.), applied to tomatoes (Lin and Chuen, 1993) or sugar cane production (Pan *et al.*, 1989) or after composting to corn (Chang, 1997), radishes and tree seedlings (Cho *et al.*, 1997) or other crops (Kimmons *et al.*, 2003) or after vermiculture to crops (Pauli, 1999).

**4. Cultivation of other species.** *Lentinula edodes* spent substrate has been recycled in the production of other mushroom species such as *Pleurotus* spp. (Jaramillo, C., Colombia, pers. com.; Royse, 1992; Nakaya *et al.*, 1999), or mixed into *Agaricus* substrate (Jim Yeatman, USA, pers. com.).



**Figure 2.** Spent shiitake substrate used as a crop fertilizer in China

**5. Food for animals.** Not only does shiitake serve as a nutritious food for humans but also researchers have investigated spent shiitake substrate as a food for animals. These studies include: ground waste logs from natural log shiitake cultivation (Yoshida *et al.*, 1978), rice straw fermented with waste shiitake sawdust media, corn and molasses (Cho *et al.*, 1997; Lin *et al.*, 1998a, b), degradation studies (Braun *et al.*, 2000; Min, 1991; Zhang *et al.*, 1995) or indirectly as a substrate for production of worms (Pauli, 1999).

**6. Biological control of diseases.** Biological control of pests is important component of a food safety conscious society. Shiitake spent substrate has been used/studied in the suppression of *Rhizoctonia* damping-off of cabbage (Huang, 1997; Huang & Huang, 2000), disease incidence of tomato (Lin and Chuen, 1993) and as a medium for other biocontrol antagonists (Raziq and Fox, 2004).

**7. Alternative fuel.** Spent shiitake logs have been used as alternative fuel (Dias, E. S., Brasil, pers. com.; Pauli, 1999) (Figs. 3).



**Figure 3.** Spent shiitake substrate is first air dried (A) and then utilized as a fuel source for a mushroom drier (B).

8. **Vermiculture.** In China extensive production of worms from spent shiitake substrate are produced (Pauli, 1999).

9. **Source of degradative enzymes.** The spent substrate of the white-rot basidiomycete, *Lentinula edodes*, is a source of degradative enzymes (Mishra and Leatham, 1990).

10. **Plastic bag recycling.** Plastic bags are used to hold and form the shiitake substrate. These spent plastic bags can be recycled into other reusable plastic materials (sources: MushWorld; Hsu, L. , USA, Unicorn Imp. & Mfg. Corp., pers. com.) (Figs. 4).



## Conclusion

The shiitake mushroom (*Lentinula edodes*), based on the limited published literature, has considerable potential to be re-used in bioremediation, crop production and pest management, animal husbandry, alternative farming, industrial processes or bioproducts. The re-cycling, as fuel, is a marginal re-use. However, the benefits are greater from other re-uses. In the short term, the best utilization of the spent substrate would be in the agricultural and horticultural industries as a soil amendment either directly or after composting. This utilization would not only enhance crop production but would have the potential to reduce pathogens of these crops. In general, agriculture and horticulture have benefited from re-use of spent mushroom substrates. In the long term, the spent shiitake substrate has the prospective as having significant value for commercial re-utilization in environmental reclamation and industrial sectors. Significant investment in research is required to determine the particular benefit to horticultural crops, the environment or the industrial sectors.

## REFERENCES

- Braun, A., M. Wolter, F. Zadrazil, G. Flachowsky, and C.C. Mba. 2000. Bioconversion of wheat straw by *Lentinus tuber regium* and its potential utilization as food, medicine and animal feed. *Mushroom Science* 15(2): 549-558.
- Chang, F. 1997. Composting experiment using material from spent shiitake mushroom sawdust bag. *Forest Products Industries* 16(2): 291-299.
- Chang, S.T. 1999. World production of cultivated edible and medicinal mushrooms in 1997 with emphasis on *Lentinus edodes* (Berk.) Sing. in China. *International Journal of Medicinal Mushrooms* 1: 291-300.
- Chang, I.S., P.K. Shin, B.H., and B.H. Kim. 2000. Biological treatment of acid mine drainage under sulfate-reducing conditions with solid waste materials as substrate. *Water Research* 34(4): 1269-1277.
- Chiu, S.W., M.L. Ching, K.L. Fong, and D. Moore. 1998. Spent oyster mushroom substrate performs better than many mushroom mycelia in removing the biocide pentachlorophenol. *Mycological Research* 102(12): 1553-1562.
- Cho, N.S. et al. 1997. Development of new technology for the utilization of waste shiitake bedlogs: development of ruminant fodders with shiitake bed logs.
- Cho, N.S. et al. 1997. Development of new technology for the utilization of waste shiitake bedlogs: manufacturing of organic composts from shiitake bedlogs.
- Cho, N.S. et al. 1997. Development of new technology for the utilization of waste shiitake bedlogs: special planting media from organic composts of shiitake bed logs.
- D'Annibale, A, C. Crestini, V. Vinciguerra, and G.G. Sermanni. 1998. The biodegradation of recalcitrant effluents from an olive mill by a white rot fungus. *Journal of Biotechnology* 61(3): 209-218.
- Kimmons, T.E., M. Phillips, and D Brauer. 2003. Small farm scale production of aerobic compost from hardwoods pre-digested by *Lentinula edodes*. *Journal of Sustainable Agriculture* 23(1): 109-123.
- Huang, J.W. 1997. Prospects for use of agricultural wastes for control of crop diseases. In: C.T. Lo and L.Y. Cho, eds; *Proceeding of a Symposium on New Techniques for Plant Protection*. Taiwan Agricultural Research Institute Special Publication No. 57. pp 151-157.
- Huang, J.W. and H.C. Huang. 2000. A formulated container medium suppressive to *Rhizoctonia* damping-off of cabbage. *Botanical Bulletin. Academia Sinica* 41: 49-56.
- Lin, T.C. and S.H. Chuen. 1993. Utilization of waste mushroom compost for tomato production. Bulletin of Taichung District Agricultural Improvement Station 40: 37-44.
- Lin, G.Z., C.D. Kim, C.S. Ra, T.S. Sim, T.S. Oh, J.S. Shin and B.J. Hong. 1998a. Characteristics of waste sawdust after shiitake culture (WSSC) and potential of using WSSC for the treatment of rice straw to improve the feed value. *Korean Journal of Animal Nutrition and Feedstuffs* 22(4): 229-236.
- Lin, G.Z., C.S. Ra, J.M. Kil, B.W. Kim, U.G. Kweon, J.S. Shin, and B.J. Hong. 1998b. Effects of aerobic treatment using shiitake culture on degradation characteristics of rice straw in the rumen. *Korean Journal of Animal Science* 40(4):381-390.
- Min, D.S. 1991. On the mushroom cultivation of oak (*Quercus*) chip and used culture medium of *Lentinus* into feedstuff. *Journal of Korean Forestry Society* 80(4): 436-444.
- Mishra, C., and G.F. Leatham. 1990. Recovery and fractionation of extracellular degradative enzymes from *Lentinula edodes* cultures cultivated on a solid lignocellulosic substrate. *Journal of Fermentation and Bioengineering* 69(1): 8-15.
- Nakaya, M., Yoneyama, S., Kato, Y., and A. Harda. 1999. Cultivation of some important edible mushrooms using the sawdust from waste shiitake bed logs.  
available at <http://www.worldmushroomsociety.com>
- Okeke, B.C., J.E. Smith, A. Paterson, and I.A. Watson-Craik. 1993. Aerobic metabolism of pentachlorophenol by spent sawdust culture of "shiitake" mushroom (*Lentinus edodes*) in soil. *Biotechnology Letters* 15(10): 1077-1080.
- Pan, T.G., Y.Z. Wang, and Y.Q. Ke. 1989. Effects of applying the used bagasse substrate of shiitake cultivation to sugarcane field on the cane growth and the soil ecology. *Journal of the Fujian Agricultural College* 18(4): 515-519.
- Pauli, G. 1999. Earthworms, mushrooms and zero waste in China. *Bicycle* 40(2): 68-69.
- Raziq, F., and R.T.V. Fox. 2004. Cultural techniques for improvement in biocontrol potential offungal antagonists against *Armillaria* root rot of strawberry plants under glasshouse conditions. *Biological Agriculture and Horticulture* 22(3): 271-287.
- Royse, D.J. 1992. Recycling of spent shiitake substrate for production of the oyster mushroom (*Pleurotus sajor-caju*). *Applied Microbiology and Biotechnology* 38(2): 179-182.
- Yoshida, J., K. Sugihara, and R. Nakamura. 1978. Effects of physical treatments on high fibrous materials. *Scientific Reports of the Faculty of Agriculture Ibaraki University* 0(26): 85-92.
- Zhang, C.K., F. Gong, and D.S. Li. 1995. A note on the utilization of spent mushroom composts in animal feeds. *Bioresource Technology* 52(1): 89-91.

## Part I Shiitake

## Chapter 7

Shiitake Post Harvest

## PROCESSING SHIITAKE

Leifa Fan<sup>1</sup>, Huijuan Pan<sup>1</sup>, and Yingmei Wu<sup>2</sup><sup>1</sup>Horticultural Institute, Zhejiang Academy of Agricultural Sciences, Hangzhou, 310021, P.R. China \*(fanleifa@yahoo.com.cn)<sup>2</sup>Zhejiang Qingyuan Nature Co., LTD, P. R. China

## Fresh Shiitake in the Market

Some people prefer the fresh shiitake, because these mushrooms have a particular taste and delicacy. Shiitake is easy to prepare in dishes with vegetables. Some people enjoy the special fragrance of dried shiitake. Although dried shiitake can be stored for a long time, many farmers, especially those living near cities or shiitake processing factories, prefer to sell fresh mushrooms because they need to see returns on their investment quickly and because they must use additional labor for the drying process.

Fresh shiitake mushrooms have a short shelf life, so they must be sold quickly or preserved in cold storage. Even using cold storage the shelf life of fresh shiitake is limited to 2 weeks. The best method for storing fresh shiitake is to keep them at 1-4 °C, packed in containers wrapped with microporous film. This can minimize respiration, reduce the humidity in the container and diminish spoilage (the growth of bacteria and fungi).

**Shiitake Preservation** (by Maria Catarina Megumi Kasuya, Brazil)

In the Brazilian market shiitake mushrooms are mostly sold fresh, being packaged in expanded polystyrene trays that are covered with a stretched PVC plastic film. In this condition, the shelf life of the product can be as long as seven days at refrigeration below 10 °C (Santana, 2003). Wrapping the trays with films of lower permeability enhanced the shelf life up to 15 days, under the same refrigeration storage temperature. One, two, three, four and five layers of PVC plastic film have been tested. When one layer is used the result is shown in Figure 1A and when with two, three or four are used the results are similar to those in Figure 1B, but when five layers are used, fermentation begins and the mushrooms are destroyed. Considering the actual demand for fresh and ready to eat products, minimally processed shiitake was evaluated, but the steps of washing and sanitation reduced the shelf life and accelerated the chemical spoilage.



**Figure 1.** Shiitake in expanded polystyrene trays and covered with a stretched PVC plastic film, one layer of the PVC plastic film (A) and two layers of the PVC plastic film (B), after 15 days storage at 10 °C.

## Processing for Long-term Preservation

There are many methods of long-term preservation, including drying, canning, and pickling. The quality of the preserved product is comparable with that of fresh shiitake if the processing and storage are done properly. Some consumers prefer the dried shiitake.

Not only is drying environmentally safe, the technique has been perfected to the extent that the dried shiitake maintain their shape and color. There are several methods commonly employed for shiitake drying.

### Drying

**Sun drying:** Shiitake mushrooms are spread on shelves in such a way that the gills face upward and are directly exposed to sunlight. The drying time required will vary depending on the weather conditions. In general, the quality of the sun-dried shiitake is lower than that dried by the thermal method.

Sun drying is used currently at initials only when the shiitake is over produced or over wetted and when the sunlight is strong. However, the sun dried fruitbodies for one or two days need to be enhanced the flavor and appearance by the thermal process.



Figure 2. Shiitake drying under sunlight

**Thermal drying:** Thermal drying uses hot air blown into the dryer in which the shiitake is arranged on shelves (Fig. 3). Hot air can be produced by electric power or burning charcoal and then delivered through recirculation vents. The size of the drying chamber varies depending on the production scale. Usually, 15 shelves are installed with an interval of 15cm between shelves. Shiitake are placed on the shelves with gills upward (Fig. 4).



Figure 3. Large chamber for shiitake drying



Figure 4. Gills face upward on the shelf

The drying chamber should be maintained at 40-50°C during 24 hours. Growers are advised to sort shiitake according to quality grade (thickness and size) before drying. The dried shiitake should be cooled one hour before termination of drying process, and then should be put into polyethylene bags, sealed and kept in a dry, cool and dark place. For prolonged storage, the shiitake should be packed in cartons or wooden boxes and kept in a low temperature storage area. The shiitake produced by this method have better quality including higher hygienic conditions and brighter color compared to sun-dried mushrooms. Dried shiitake easily absorb moisture from the air, so they should be properly stored and examined frequently for insects or molds, especially during the rainy seasons.

### Canning and bottling

Canning and bottling are alternate methods of shiitake preservation. The processes of canning and bottling are similar, and differ mainly in procedure during sterilization and handling afterwards. Cans may be sterilized when they are tightly sealed, but bottle must be sterilized with the caps closed halfway. The canning process requires a rapid cooling in the wash sink after the autoclave, while the bottling process requires a slow cooling in fresh air after the caps have been sealed. Both processes are divided into ten basic operations: selection, trimming, cleaning, cooking, canning, sterilization, cooling, labeling, packing and storage.

The shiitake used for canning are generally fresh and healthy. If the mushrooms are not canned immediately, they should

be refrigerated until processing starts. Grading and trimming are required for shiitake product uniformity. The stems should be trimmed to 1cm in length. Cleaning the mushrooms involves washing the mushrooms in water at 90°C for 5 minutes at a ratio of 1:1.5 (shiitake volume: water volume), as this will eliminate the air in the shiitake. The shiitake are then placed in the cans and sodium chloride (2.5%) and citric acid (0.2-0.5%) are added. Before sealing the can, the air is removed. Sterilization of the sealed cans is done in an autoclave at 121-130°C for 15 minutes.

The canning process requires a variety of equipments, so this method is widely used by the larger members of the industry. Small-scale growers perform bottling without difficulty. Canned and bottled shiitake are consumed by restaurant and hotel customers.

Home bottling is a simple procedure of applying heat to food in a closed jar in order to interrupt the natural decaying that would otherwise take place. It requires "preprocessing" or "heat processing" foods. Proper home bottling includes:

1. Placing prepared food in home jars (bottles) which are then sealed with two-piece vacuum caps;
2. Heating the filled jars (bottles) to the designated temperature using the correct type of bottle for the food being processed;
3. Processing the filled jars (bottles) for the required time as stated by an up-to-date, tested recipe in order to destroy the spoilage microorganisms and inactive enzymes;
4. Cooling jars (bottles) properly, allowing the lids to vent excess air from the jars in order to form a vacuum seal.
5. After 24 hours, checking the lids for a seal. Sealed lids curve downward. Press the center of the lid to ensure it does not flex up or down. Reprocess or refrigerate any unsealed jars. Remove bands. Wipe jars and lids with a clean, damp cloth and dry. Wash bands in soapy water, dry and store.
6. Label and store jars in a cool, dry, dark place. For best quality, use home canned foods within one year.

When followed exactly, the processing methods of tested home canning recipes adequately destroy normal levels of heat-resistant microorganisms. After processing and upon cooling, a vacuum is formed and the lid seals onto the jar. This ensures that home canned foods will be free of spoilage when the jars are stored properly and remain vacuum-sealed. This seal prevents other microorganisms from entering and contaminating the food.

### Pickling

- 1) Salt: After cleaning and cooking for 2 minutes, the shiitake is drained and transferred to a container (large or small) and salt is added (22% w/w) (Fig. 5). Before eating, the shiitake is rinsed in water and/or prepared with other spices according to personal preference.
- 2) Vinegar: The shiitake for pickling should be firm and fresh. Preparers should always ensure that the mushrooms are as fresh as possible, and are prepared correctly.

Use only the best quality vinegar with an acetic acid content of 5-7%. Malt vinegar is recommended for general pickling purposes, but white wine or cider vinegar can be used for a more delicate flavor and color. More adventurous preparers could try vinegar flavored with herbs and spices. Always use stainless steel knives and utensils. Peel and trim the mushrooms where required. Remove any moldy or marked parts. If cooking is required, steam them in light syrup.

In some cases the shiitake will need salting to extract excess moisture in order to the vinegar can preserve the mushrooms. The recipe followed should indicate either dry-salting or wet-salting. For dry-salting, shiitake are placed in a non-metallic bowl, covered with salt and left overnight. For wet-salting, a brine solution is poured over the shiitake and then left to soak overnight. After salting, rinse shiitake several times to remove all salt, and pat dry with kitchen paper.

Pack the prepared shiitake into sterilized containers. Do not pack too tightly. Cover the packed shiitake with vinegar, and tap the sides to release any pockets of air. Leave at least 1.5cm space at the top of the container after packing, so that you can pour the vinegar or syrup in to almost the top of the jar.

Ensure everything is well covered. If necessary use a crumpled piece of greaseproof paper to push down the mushrooms until they are completely under the liquid. This paper can be removed after 2 weeks. Tightly seal the containers with the lids.



Figure 5. Shiitake pickling

### Frozen slices or pieces

Nowadays, frozen food products are widely accepted by urban consumers due to their convenient preparation. Shiitake is also entering the frozen food industry. Some shiitake products are mixed with legumes like green beans or with corn. The processing is the same as for the other legume or corn frozen product. After cleaning, the shiitake is sliced or cut in pieces by a machine, then, it is cooked. After draining the water off, the mushrooms are frozen immediately. After packing, they can be stored in a frozen storage for a long period, and can be sold in all seasons (Fig. 6).



Figure 6. Frozen pieces of shiitake

### Shiitake powder

During harvesting and processing, there are many broken shiitake pieces, cut stems and deformed shiitake. These are either incorporated into the processed products or they are ground into powder. Shiitake powder is generally used as a food additive (Fig. 7).



Figure 7. Shiitake powder as food additive



Figure 8. Mushroom tea including shiitake

### Shiitake tea

To make a tea from dried shiitake, cover a handful of the dried mushrooms with boiling water, steep for 10-30 minutes, and strain. The leftover mushrooms may be used in cooking.

Some people like to boil dried shiitake in water and simmer for 15 minutes. Season the shiitake with soy sauce and eat it. Drink the water hot. Some like to soak 2-3 dried mushrooms for an hour, or until they are soft, then add 4 cups of water, and bring to a boil with a pinch of sea salt. They simmer this for about 20-30 minutes, until 3 cups of tea are left, and then drink half a cup at a time.

Instant shiitake is available in either powder or granulated form in glass jars or in sachets. Powders and granules are preferred by both producers and consumers because of the ease of dissolving in hot water. It is up to the user to control how much is used.

Dried shiitake is ground and then put into solution with water. This stage is called the extraction. This solution may be further concentrated before the drying process begins by either vacuum evaporation or freeze concentration.

Drying is a very important step and two different methods are used in the processing plants: freezing and spray drying. Each has its own advantages and disadvantages.

Freeze-drying: the basic principle of freeze-drying in the process for producing instant shiitake is the removal of water by sublimation. Freeze-drying has grown in popularity to become a very common method. Although it is frequently more expensive than other methods of drying it generally results in a higher quality product, a factor which is very important in the instant product market. Freezing too fast leads to large ice crystals and a very porous product and can also affect the color of the shiitake granules.

Spray drying: This method of drying is preferred to freeze-drying in some cases because of its cost effectiveness, short dry-

ing time, usefulness when dealing with such a heat sensitive product, and the fine, rounded particles it produces. Spray drying produces spherical particles of size roughly equal to  $300\mu\text{m}$  with a density of  $0.22\text{g}/\text{cm}^3$ . To achieve this, nozzle atomization is used. Various methods of nozzle atomization can be used in combination with high-speed rotating wheels.

## REFERENCES

- Fan, L.F. 1990. Mushroom cultivation and processing. In: Ding C.K., Fan L.F., and Jiang Y.Q. eds: *Handbook for Home Income* (ISBN:7-5390-0371-5/S.98). Jiangxi Science and Technology Publication House. pp. 80-113.
- He, Y.S. 1994. *China Shiitake* (ISBN: 7-5323-3415-5/S.380). Shanghai Science and Technology Publication House. 240pp.
- Huang, N.L. 1993. *China Edible Fungi Cyclopedia* (ISBN: 7-109-02614-0/S.1681). China Agricultural Publication House. 448pp.
- Tao, J., Q. Xiao, N. Chen, and D. Li. 2003. Processing techniques of shiitake mushroom stem. *Resources Development & Market* 19(6): 359-360.

## Part I Shiitake

## Chapter 7

Shiitake Post Harvest**CONSIDERATIONS RELATED TO FARM  
MANAGEMENT AND MARKETING**

Seungwoo Kang (Richard)

MushWorld, 150-5 Pyungchang, Jongro, Seoul, Korea (swkang@mushworld.com)

Cultivation skills are one half of a mushroom enterprise, and management & marketing skills are the other half. These financial management skills have a direct effect on the profitability of a farm and every serious mushroom farmer should use market analysis, careful financial planning, and customer feedback as tools to help make decisions about farm management.

**Farm Diary**

Growers need to keep records of cash and product flow, farm activities, and changes to the farm. These accounts are essential for preparing the monthly and yearly accounts. Most successful farmers make frequent entries in a farm diary. The table below shows some example of keeping records from virtual shiitake farmer, Mr. Lentinula's operation.

**Table 1.** Cash and product flow example of virtual shiitake grower, Mr. Lentinula

Date (Jan. '05)	Content	Amount	Cost	Revenue	Self consumption
01	Labor	1 person	10		
02	Tax		2		
03	Selling fresh shiitake	100kg		200	
04	Sawdust	20kg	10		
05	Fresh shiitake	5kg			10
...	...	...	...	...	...
23	Plastic sheet for repairing growing house	2 rolls	4		
...	...	...	...	...	...
	Monthly total				
	Yearly total				

There is no fixed form for a farm diary that will fit every shiitake grower, but some form of diary is essential. Growers should record not only growing activities and environmental parameters. A diary should also include detailed thoughts, new information acquired, and ideas for future management activities. Photos and illustrations are also useful.

**BEP (Break-Even Point) analysis**

A BEP analysis will show the farmer how much production and sales will be required to break even with the total cost spent on one batch production. Though, this tool is limited to creating a financial status estimate, so it may not cover all decision parameters. Its assumption is constant operation.

Fixed costs are constant costs separate from the specific crop production costs. Fixed costs may include depreciation and marketing. Variable costs are those costs that increase with the production quantity.  $BEP = \text{fixed cost} / \{(\text{revenue} - \text{variable})\}$

cost)/revenue}

The example shown below is for a theoretical farmer, Mr. Lentinula, who produces 100kg of shiitake. In this case,  $BEP = 200 / \{(200-100)/200\} = 400$

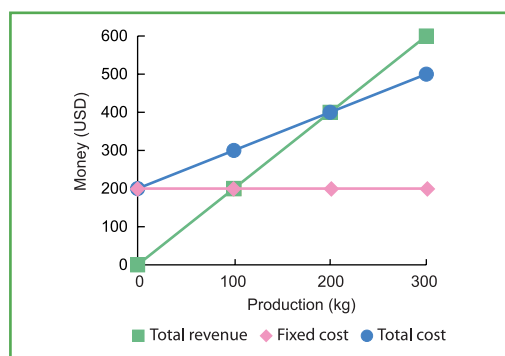
**Table 2.** BEP analysis of Mr. Lentinula

		Item	Cost & revenue (USD/batch)	Note
Cost	Fixed cost	mixer	20	Depreciation for one batch
		growing room with racks	30	"
		incubation room with racks	30	"
		spawning room	30	"
		heater, cooler, fan	20	"
		sterilizer	20	"
		labor	30	Mr. Lentinula
		marketing	20	flyers, samples
		<b>total fixed cost</b>	<b>200</b>	
	Variable cost	substrate mixture material	25	USD0.25/kg
		spawn	25	"
		bags and caps	25	"
		Misc. (power, water, tax, etc)	25	"
		<b>total variable cost</b>	<b>100</b>	
<b>total cost</b>		<b>300</b>		
Revenue	fresh shiitake	<b>200</b>	USD2 ×100kg	

This situation can be represented in the chart shown right. Fixed costs are shown as the pink line, variable costs are represented by the area between the blue line and the pink line, total cost is shown as the blue line, and revenue is shown as the green line.

It can be seen that Mr. Lentinula has his BEP at 200kg with USD400 total cost for one plot, which is the point on the chart where the green line and blue line meet. Unfortunately, at this time, he produces only 100kg shiitake with a total production cost of USD300 and a revenue of only USD200, so he is working at a loss. Assuming that one batch takes one month, he loses USD100 monthly.

To make his farm profitable, Mr. Lentinula needs to lower costs, boost production to over 200kg, or find a buyer who will pay more per kg for his products.



**Figure 1.** BEP chart from Table 2.

**SWOT (Strengths, Weaknesses, Opportunities, Threats) analysis**

SWOT analysis is a methodology by which growers can analyze their operations and possibly understand appropriate changes for the future. Farmers wishing to use this system can make a blank version of the following example table, and fill in their own answers.

**Table 3.** SWOT analysis of Mr. Lentinula

<b>Internal</b>	<b>Strengths</b>	<b>Weaknesses</b>
	<ul style="list-style-type: none"> <li>- High cultivation skill</li> <li>- No debt</li> <li>- Low pests and diseases</li> <li>- Strong will of marketing</li> <li>- Continuous research and development</li> </ul>	<ul style="list-style-type: none"> <li>- No automation (high portion of labor)</li> <li>- Far from market</li> <li>- No dryer and cold storage</li> <li>- No more capital for investment</li> <li>- Outdoor incubation takes long time</li> </ul>
<b>External</b>	<b>Strategies</b>	
	<ul style="list-style-type: none"> <li>- Steadily increasing demand</li> <li>- Preference of fresh shiitake</li> <li>- Increased demand for organic, fresh, high quality food</li> <li>- Shiitake promotion policy of government</li> <li>- Supply fluctuation by season</li> </ul>	<ul style="list-style-type: none"> <li>- Regulation of production amount : increase production at feeding and rainy season</li> <li>- Aggressive marketing of benefit of shiitake</li> <li>- Establishing website for online consumers</li> </ul>
	<b>SO strategy</b>	<b>WO strategy</b>
	<ul style="list-style-type: none"> <li>- Increase average production and decrease labor cost by automation</li> <li>- Adoption of strains exclusively for fresh shiitake</li> <li>- Fund application for cold storage</li> </ul>	<ul style="list-style-type: none"> <li>- Increase average production and decrease labor cost by automation</li> <li>- Adoption of strains exclusively for fresh shiitake</li> <li>- Fund application for cold storage</li> </ul>
	<b>Threats</b>	<b>ST strategy</b>
	<ul style="list-style-type: none"> <li>- Increasing competition with other mushrooms and farms</li> <li>- Low recognition of consumers for shiitake</li> <li>- Extreme consuming pattern: high quality and cheap</li> <li>- Unstable supply of substrate material and spawn</li> <li>- Globalization by like WTO, DDA, FTA</li> <li>- Environmental issues</li> </ul>	<ul style="list-style-type: none"> <li>- Quality division by strict pruning</li> <li>- Develop other mushroom species by R&amp;D</li> <li>- Marketing for consumer behavior and recognition</li> </ul>
		<b>WT strategy</b>
		<ul style="list-style-type: none"> <li>- United shipping and marketing by cooperation</li> <li>- Brand making for differentiation from other shiitake farms</li> <li>- Establishing website for foreign market (low tariff)</li> <li>- Direct marketing of staffs</li> <li>- Concentrate on high quality</li> <li>- Using surplus labor, recycle spent substrate in vermiculture</li> </ul>

## Market Situation

New mushroom markets are often characterized by low recognition and consumption of mushrooms. In these cases, a variety of different marketing efforts is needed to raise the public consciousness concerning the desirability of consuming mushrooms. With over supplied, it is important for growers to have precise sales information in order not to over-produce. In growing markets where there is a greater demand than there is supply, production increasing methods are appropriate. When the market is old, characterized as calm and balanced, growers may wish to grow additional types of crops.



**Figure 2.** Small packed shiitake can be marketed directly to consumers.

Shiitake mushrooms from various sources are assembled at the wholesale markets and sold at prices that are lower than the retail prices. Though the wholesale market experiences relatively low prices, producers can sell their mushrooms relatively easily at these markets.

In all markets, prices fluctuate according to supply and demand. In the hot summer season when shiitake availability decreases, the prices rise. During the rainy season, supply goes down and prices go up. School consumption also has an impact on shiitake prices. During school vacation when school consumption stops, both demand and prices decrease.

Retailers obtain their shiitake from the wholesale markets or they buy from suppliers who supply shiitake. In order for shiitake producers to enter the retail market themselves, they should be able to provide constant quality and a year round supply. Growers wishing to sell at retail should ensure

their product quantity and quality by cultivating indoors and considering cooperation with other growers. Strict grading is also an important step in ensuring product quality.

Cooperatives, co-production, co-processing, and co-shipping allow small growers to become more aggressive in market-

ing their products, but it is important that factors such as quality control, labor division, and profit sharing be determined ahead of time.

Consumer communications must be maintained through continuous exchange with buyers using methods such as email, letters, and phone calls. Organic certification also helps create a positive image. Highland Birchwoods, a UK mushroom marketing agency advises growers who attend their demonstration program to:

1. Give lots of trial samples to lots of chefs.
2. Telephone customers, weekly, at a time when they are not busy.
3. Grade the shiitake, selecting only the top quality mushrooms, and packing them in standardized mushroom containers.
4. Deliver the shiitake regularly.
5. Be flexible regarding payment. Fit in with the customer's accounting system, as each one is different.

## REFERENCES

- Beets, A.E., and M. Kustudia. 2004. Mushroom cultivation and marketing. *Horticulture Production Guide*. ATTRA Publication #P087. available at <http://www.attra.org/attra-pub/mushroom.html>
- Haugen, J., G.B. Holcomb, W. Howard, and Bud Kerr, Jr. 1993. A small scale agricultural alternative- shiitake mushrooms. available at <http://www.mushroomcompany.com/shiitake.html>
- Highland Birchwoods, U.K. Native woodland demonstration programme - Information sheet 4: Growing shiitake mushrooms (*Lentinula edodes*) in the highlands. available at <http://highlandbirchwoods.co.uk>
- Jenkins, D. H., S.K. Jonathan, A.L. Hammett. *Shiitake Mushrooms Production and Marketing (SPF-2)*.
- Lee, S.D., S.J. Park, J.Y. Kim, and H.J. Lee. 2000. *Marketing from the Perspective of Corporate Level*. Hakhyun Press.
- Mycosource Inc. *Natural Log Shiitake Mushroom Production, Processing and Marketing*.
- Thomas, M.G., and D.R. Schumann. 1993. Income opportunities in special forest products: self-help suggestions for rural entrepreneurs. *Agriculture Information Bulletin AIB-666*, U.S. Department of Agriculture, Washington, DC.

## Part II Mushroom for Better Life

## Chapter 8

Mushroom for a Living**COPRINUS MUSHROOM CULTIVATION  
IN THAILAND**

Praphant Osathaphant

Maejo University, Thailand (praphant@mju.ac.th)

Thailand has an environment that is appropriate for growing many kinds of mushrooms, including even some temperate mushrooms that are cultivated in the north. Agricultural wastes from the fields can be used as growing substrates and labor costs are still low. *Coprinus* mushrooms are called “Shaggy Ink Cap” in Thailand, “Shaggy Mane” or “Lawyer’s Wig” in North America and Europe, and “Chickenleg mushrooms” in China. *Coprinus* mushrooms have long been a favorite among mushroomers.

*Coprinus* mushroom belongs to *Coprinus*, Coprinaceae, Agaricales, Basidiomycetes. Its scientific name is *Coprinus comatus* (Muller: Fries) S.F. Gray. This mushroom can adapt to a wide variety of indoor and outdoor substrates. A *Coprinus* mushroom’s fruiting body has a cap 4-10(15)cm high and 3-4(5)cm thick, vertically oblong, dingy brown at first, soon white, and decorated with ascending scales. The gills are crowded, white to pale, long, broad and slightly attached or free to the stem. The stems are 6-12(15)cm long by 1-2cm thick, equal, hollow, bulbous at the base, and adorned with a movable, membranous collar-like ring, that separates from the cap margin as the mushrooms enlarge (Fig. 1). The natural habitats are in grass by roadsides, on rubbish heaps or lawns, and particularly on recently disturbed soil. The mushrooms appear in the late summer and fall throughout the temperate regions of the world. *Coprinus* mushroom has very short production cycle of 1-2 month, from substrate preparation to the end of harvest. It is cultivated by shelf method indoor or bundle method outdoor in Thailand.

Figure 1. Fruiting bodies of *Coprinus comatus***Indoor Cultivation of Coprinus Mushroom (Shelf Method)**

The indoor cultivation of *Coprinus* mushroom is performed throughout the year. This mushroom grows well in organic compost whose ingredients are partially decomposed or degraded.

**Substrate materials**

Thailand is an agricultural country, and produces a lot of agricultural wastes. These wastes include rice straw, soybean pod husks, corn stems, corncobs, sorghum stems, dried banana leaves and stems, dried grass, fresh and dried water hyacinth, sawdust, and others (Fig. 2).

The yield of fresh *Coprinus* mushroom from soybean pod husk waste compost is about three to four times higher than from rice straw. Thai farmers grow a great deal of soybean annually, and the crop yield is about



Figure 2. Dried rice straw

270,000 tons per year. This results in a large amount soybean pod husk waste materials available for growing mushrooms.

### Compost preparation

The rice straw should be fresh and clean, not old or dirty. This straw should be chopped into pieces 40-50cm long, by hand or mechanically. The chopped rice straw should then be immersed in water and thoroughly soaked for 4-6 hours, depending on the capacity of straw to absorb and retain the moisture. Some growers irrigate the straw directly until it is saturated with water (Figs. 3 and 4). Other easily decomposable agricultural wastes can be also used to replace rice straw.



Figure 3. Rice straw waste compost



Figure 4. Soybean pod husk waste compost

Formula 1 takes about eight days for preparing composts and formula 2 takes about five days. Formula 1 requires more time than formula 2 because formula 1 does not make use of dried animal dung, which contains many microorganisms that promote fermenting.

100kg of dried rice straw or soybean pod husk or other agricultural wastes is put inside a wooden box of  $1.5 \times 1.5 \times 0.5$ m. Water and 2% fertilizer 16-20-0 can be added gradually and the mix fermented for three days. After that initial processing the wooden box is taken off and the fermenting composts are turned and 1% limestone is added. After three days, the fermenting compost is turned and thoroughly mixed by means of a mechanical mixer, and supplemented with 5% rice bran, 2% fertilizer 15-15-15 and water when needed. The mixed and supplemented compost is then piled up and covered with plastic sheets. Fermentation is continued for another two days. Using this formula, it takes about eight days to prepare the substrate compost.

100kg of dried rice straw or other agricultural wastes such as dried soybean pod husks are put inside a wooden box of  $1.5 \times 1.5 \times 0.5$ m. Water, 1-1.5% urea or ammonium sulphate, 5-10% dried animal dung and 1% limestone can be added gradually and the mixture fermented for three days. After that, the wooden box is taken off, the compost is turned over and 1-2% double superphosphate and 1-2% gypsum is added and the whole thoroughly mixed by means of a mechanical mixer. The mixed and supplemented compost is then piled up and covered with plastic sheets. After two days, the fermenting compost is turned over again. Using this method, it takes about five days to prepare the compost and turn the fermenting compost two times.

Table 1. Formulations of substrate materials

Formula 1	Unit by weight	Formula 2	Unit by weight
Dried rice straw or other agricultural wastes	100	Dried rice straw or other agricultural wastes	100
Fertilizer 16-20-0 (Ammonium phosphate subphate)	2	Urea or ammonium sulphate	1-1.5
Limestone	1	Dried animal dung (chicken, cow, pig etc.)	5-10
Rice bran	5	Limestone	1
Fertilizer 15-15-15 (Compound fertilizer)	2	Double superphosphate*	1-2
		Gypsum	1-2

\*Formula 2: 16-20-0 fertilizer or 20-20-0 fertilizer can be used instead of urea and double superphosphate

### Spawn preparation

The spawn for cultivating *Coprinus* mushrooms in Thailand is available in two forms; grain spawn and compost spawn. In grain spawn preparation, 10kg of sorghum grains are boiled in 15 l water until 20% of the grains have cracked. The excess water is drained off and the grains are cooled in sieves. The grains should be turned several times with a spoon to assist quick cooling. The prepared grains are then filled into 300cc bottles or polypropylene bags of about 150-200g per bottle or bag and then the spawn and containers are sterilized in an autoclave for 45 minutes at 15 psi. After sterilization, the bottles are inoculated with bits of agar medium colonized with mycelium (Fig. 5) and then incubated at 21-27°C in a dark place. The mycelium completely spreads through the grains in about two weeks (Fig. 6).

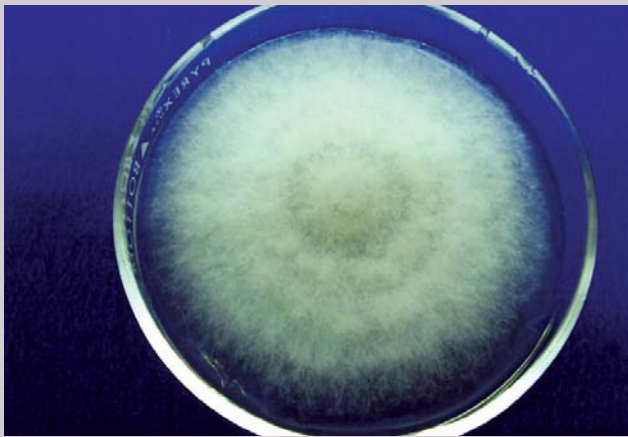


Figure 5. Pure culture of *Coprinus comatus*



Figure 6. Grain spawn of *Coprinus comatus* from sorghum seeds

### Filling

Before filling the compost into shelves, the compost is broken into small pieces by a machine and growers may also add with some supplements such as rice bran. The compost is packed into the shelves in the mushroom growing house. The post-fermented compost is poured from the plastic baskets onto the shelf and this is repeated until each shelf has the allotted amount of compost. The layer of compost is about 8-10 inch thick. The compost is then flattened by hand from both sides of the shelf. Generally, the width of a shelf is 1-1.2m and the length of a shelf vary depending on the length of the mushroom growing house.

### Pasteurization and substrate inoculation

When the compost is completed, steam is blown into the house to maintain the temperature at 65-70°C for 4-6 hours (Fig. 7). When the room temperature has cooled gradually down to 35°C with the door closed, the spawn is inoculated about 2cm deep into or on top of the cooled compost. The amount of spawn used is 2.5-3% of the dry weight of the compost but this proportion can be adjusted to a grower's preference.



Figure 7. Steam generator for pasteurization

### Fructification

After spawning, the temperature of the mushroom growing house is maintained at 38-45°C with the door closed during the three day period of spawn running. No water and light are needed, but aeration is required. Three days later, actinomycetes and some thermophilic fungi usually develop in and on the beds with the mycelia of *Coprinus* (Figs. 8, 9, 10, 11, 12, 13, and 14). After this period, growers sprinkle the beds with water and the growth of the actinomycetes and *Humicola* will be retarded, but the *Coprinus* will continue to grow. On the fifth day after spawning, primordia of fruiting bodies usually appear on the surface of the beds (Chang, 1982) (Figs. 15, 16, 17, and 18).



Figure 8. Partial colonization on rice straw compost



Figure 9. Partial colonization on soybean pod husk compost



Figure 10. Full colonization on rice straw compost



Figure 11. Full colonization on soybean pod husk compost



Figure 12. Mycelium of *Coprinus comatus* growing on compost



Figure 13. Shelf cultivation of *Coprinus comatus* on rice straw compost



**Figure 14.** Shelf cultivation of *Coprinus comatus* on soybean pod husk compost



**Figure 15.** Primordia formation of *Coprinus comatus*



**Figure 16.** Fruiting bodies of *Coprinus comatus* on rice straw compost



**Figure 17.** Fruiting bodies of *Coprinus comatus* on soybean pod husk compost



**Figure 18.** Fruiting bodies of *Coprinus* mushroom on soybean pod husk compost

### Mushroom growing houses

The popular size of mushroom growing house for *Coprinus* mushrooms is 4 × 6 × 2.5m or 6 × 8-12 × 2.5m (W × L × H) (Fig. 19). Mushroom growing houses can be classified into two types, those built for temporary use and for long term use. A temporary typical mushroom growing house is made of thatch and bamboo or wooden poles and shading net (Fig. 20). The long term mushroom growing houses are constructed with a bamboo wooden frame and is lined inside with 0.4mm film of polyethylene plastic sheet for maintaining the relative humidity during mushroom fruiting or controlling the steam during peak heating of composts. These houses are covered outside with the best available dried grasses and leaves.



**Figure 19.** A mushroom growing house made up of plastic sheet and shading net



**Figure 20.** A mushroom growing house made up of dried grasses and bamboo wooden frame

## Outdoor Cultivation of Coprinus Mushroom (Bundle Method)

### Selection for growing

In the field, *Coprinus* mushrooms usually appear among agricultural wastes such as rice straw, soybean pod husk, and corn-cobs, along the edges, sides, and ends of the bed. Some of the mushrooms also grow on the soil around the base of the bed. The amount and quality of these soil grown mushrooms depending on the fertility and physical properties of the soil (Chang, 1982).

In Thailand, mushroom growers usually select paddy fields for growing *Coprinus* mushroom after the rice harvest. The land should be elevated and without disturbance from termites, ants, or snails, as these pests can seriously disturb the growth of mycelia. Paddy fields are best used for large scale production. The best lands for *Coprinus* mushroom cultivation are those near water sources with good ventilation and plenty of sunshine, where the soil is fertile and slightly loose.

### Land preparation

The land on which *Coprinus* mushrooms are to be grown should first be smoothed. The land surface might be soil for outdoor or concrete for indoor cultivation. If the land surface is soil, fruiting bodies can grow on this. For the concrete surface, it is easy to wash and spray or irrigate with 0.1% chlorine solution or 2% formalin solution. To produce clean fruiting bodies, growers should lay a plastic sheet on the soil surface before piling the substrate materials.

All the soil bases should run in an east-west direction so that the rice straw beds can receive a uniform amount of sunlight and maintain equal temperatures on the long sides, for it is on these sides that most of the mushrooms will grow (Chang, 1982).

### Soaking and stacking rice straw for preparing substrate beds



The rice straw should be immersed in water, and thoroughly soaked for 4-6 hours, depending on the capacity of straw to absorb and retain the moisture. Preparing a substrate for outdoor cultivation is a different procedure from preparing a substrate for indoor cultivation because outdoor cultivation is similar to natural cultivation while indoor cultivation is much modified.

A rope is laid on the bottom of a wooden box (30 × 40-50 × 30cm), and 35kg of dried straw is piled neatly in the box (Fig. 21A). The rice straw bundle can then be tied tightly with the rope and the wooden box taken off (Figs. 21B and C). The size of these rice straw bundles is 25-30cm in diameter and they weigh 3-5kg each (Fig. 21D).

### Soaking in the mixture of hot water and additives

The substrate materials usually have limited nutrients available for the growth of mushrooms, and mushroom growers should add some nutritional additives to the substrate materials. These additives consist of 2% urea or ammonium nitrate fertilizer, 1% yeast, 1% sugarcane meal, 1% limestone and 0.1% magnesium sulphate. The mixture of additives and water is boiled at a temperature maintained at 80-90 °C. At this temperature, the substrate materials will absorb nutrients more quickly. The hot water will also kill insects and weed fungi in the substrate materials. The substrate materials are immersed in the mixture of hot water and additives for 5-10 minutes (Fig. 22) or irrigated with this mixture until the nutrients have been absorbed by the substrate materials (Fig. 23).



**Figure 22.** Substrate materials immersed in the mixture of hot water and additives



**Figure 23.** Substrate materials irrigated with the mixture of hot water and additives directly

### Spawn inoculation

After the temperature of the substrate material has decreased to 40-45 °C, it can be inoculated with spawn. One bottle of spawn should be used for 2-3 bunches. Spawn is inserted into the substrate material, which has been scooped out to a depth of 15cm at intervals of 10-15cm around the substrate beds. The inserted spawn is then covered with the displaced materials. Next, the beds are covered with thin black or blue plastic sheets and then further covered on the upper part of each bed with dried rice straw mats or Manila hemp sack to protect the beds from exposure to direct sunlight (Fig. 24). The temperature of the room is maintained at 35-45 °C during the period of spawn running. No water and ventilation are needed in this period. The mycelium completely spreads through the substrate materials in about 5-6 days.



**Figure 24.** A mushroom growing house for outdoor cultivation

### Care of the beds and fructification

After the five to six day period of spawn running, the primordia of fruiting bodies usually start to appear on the surface of the beds. The beds should be covered with a thin plastic sheet and straw mats. In this period, more ventilation is given. If the moisture content is too low, water should be supplied along the two sides. Under these conditions, it usually takes one to

two days from the appearance of minute fruiting bodies until the mushrooms are ready for harvesting. They can be harvested at least once a day in the evening. Chang (1982) reported that there are often mushrooms in different stages of development growing close together; therefore care needs to be exercised during harvesting. The harvestable fruiting bodies should be carefully separated from the straw base by lifting them, shaking them left and right, then up and down, and finally twisting them off. This prevents damage to the growing mycelium and the developing primordia. In Thailand, it is customary to pick at the early stage of fruiting.

The harvesting time can last for 20-30 days or longer. The yield may reach 60 to 100%, depending on cultivation technology, the spawn, the supplements, the care of the beds and environmental conditions.

Fruiting bodies should be picked before there is the slightest hint of the gills turning black. If picked when no basidia have matured, fruiting bodies can be kept in cold storage for 4-5 days. Moreover, they can be preserved by submerging them in cold water and storing them under refrigeration at a temperature of 8-10°C.

## Profitability of Coprinus Mushroom Cultivation in Thailand

This species adapts to a wide variety of indoor and outdoor substrates. Although the commercial cultivation of this mushroom is limited by its predisposition to disintegrate into an inky mess, this mushroom is fantastic for those who can consume it within two days of picking.

A novel antibiotic has been isolated from this species and is currently being characterized by American researchers. Ying (1987) reported that "inhibition rates against Sarcoma 180 and Ehrlich carcinoma are 100% and 90% respectively" (Stamets, 1993).

People like consuming this mushroom, and this species can grow easily both indoor and outdoor cultivation. The price of fruiting bodies is quite high when compare to other mushrooms. Cost and benefit of *Coprinus* mushroom production in Thailand is good, and the net profit per 100 packets of dried rice straw (3kg weight per packet) is THB<sup>1</sup>5,570 (USD143.56) by bundle method while the net profit by the shelf method is THB9,700 (USD250). The biological efficiency of this mushroom production is 66.67% and 75% respectively. The production period for this mushroom is quite short and last only an average of one month. Mushroom growers can grow from 10-12 crops per year and produce a large income.

**Table 2.** Cost and benefit of *Coprinus* mushroom production of bundle method (for 1 month)

Item	Quantity	Cost per unit in THB	Production cost in THB
Rice straw	100 packets	5	500
Rope	100 pieces	2	200
Additives	17 kg	40	680
Spawn	25 bottles	10	250
Fuel			200
Labor			300
Plastic sheet			200
Water and electricity			100
Total Production Cost			THB2,430 (USD62.63)
Yield			200 kg
Price per kg			THB40
Total Income			THB8,000 (USD206.19)

\* Biological efficiency = 66.67%

Note: Number of dried rice straw packets is 100. (3kg weight per packet)

Source: Aeutrakul, Anon.

Net profit = Total income - Total production cost  
 = THB8,000 - THB2,430 = THB5,570 (USD143.56)

<sup>1</sup> THB (Thai Baht, USD1 = THB38.8 in March, 2005)

One *Coprinus* mushroom grower produces 6-7.2 tons a year on average. The estimated productivity is 600kg of *Coprinus* mushrooms from 900kg of dried rice straw. A farmer can grow about 10-12 crops per year and produce the income of THB55,700-66,840 (USD1,435.57-1,722.68) per year in Thailand.

**Table 3.** Cost and benefit of shelf method (for 1 month)

Item	Quantity	Cost per unit	Production cost in THB
Fixed production cost			
- Growing house 6 × 8m			12,000
- Shelf (iron)			12,000
(wood)			8,000
(bamboo frame)			2,000
- Water sprinkling system			800
- Ventilator			4,500
- Steamer (200 l drum)	2	7,500	15,000
or steamer with stove			35,000
- Compost chopper			10,000
- Water sprayer			1,200
- pH meter (Kasetsart University)			450
- Thermometer			85
Variable production cost (cost per crop per one growing house)			
- Substrate materials	400kg	THB4/kg	1,600
- Supplements	30kg		1,200
- Fuel			300
- Spawn			800
- Labor			3,000
- Water and electricity			300
- Chemicals and hormone			500
- etc.			200
- Depreciation in value of equipments of equipments			400
Total production cost			THB8,300 (USD213.92)
Yield			300kg
Price per kg			THB60
Total Income			THB18,000 (USD463.92)

\* Production period is 30 days. Biological Efficiency = 75 %

Note : The price of mushroom fruiting bodies by shelf method is different from bundle method because time of study is different.

Net Profit = Total income - Total variable production cost  
 = THB18,000 - THB8,300 = THB9,700 (USD250)

A farmer can grow about 12 crops per year and produce the income of THB116,400 (USD3,000) per year in Thailand.

## REFERENCES

- Aeutrakul, Anon,--. *Coprinus* Mushroom Cultivation. Pathumtani, Thailand: BIOTEC Center. 112 pp. (in Thai).
- Chang, S.T. 1982. Cultivation of *Volvariella* Mushrooms in Southeast Asia. In: Chang, S.T. and T.H. Quimio, eds: *Tropical Mushrooms: Biological Nature and Cultivation Methods*. Hong Kong: The Chinese University Press. p. 221-252.
- Kurtzman, R.H., Jr. 1978. *Coprinus fimetarius*. In: Chang, S.T., and W.A. Hayes, eds: *The Biology and Cultivation of Edible Mushrooms*. New York: Academic Press, Inc. p. 393-408.
- Phillips, R. 1981. *Mushrooms and Other Fungi of Great Britain and Europe*. Toppan printing Company (HK) Ltd., Hong Kong. 288 pp.
- Stamets, P. 1993. *Growing Gourmet and Medicinal Mushrooms*. Hong Kong: Ten Speed Press. pp. 229-232.
- Su-Chun, Li, Feng Shang and Feng Chunyi. 1988. A method to keep chicken-leg mushroom (*Coprinus comatus* Gray ) fresh. *The Proceedings of 98' Nanjing International Symposium. Science and Cultivation of Mushroom*. October 12-15, 1998 at Nanjing, China. 266 pp.

## Part II Mushroom for Better Life

## Chapter 8

Mushroom for a Living**AGARICUS BLAZEI<sup>1</sup> CULTIVATION FOR  
A LIVING IN BRAZIL**

Margarida de Mendonça<sup>1</sup>, Maria Catarina Kasuya<sup>2</sup>, Anselmo Cadorn<sup>3</sup> and Ademir João Vieira<sup>4</sup>

<sup>1</sup>Microbiology and Parasitology Department, Universidade Federal de Santa Catarina, Florianópolis, Santa Catarina (SC), Brazil \*(margarid@floripa.com.br)

<sup>2</sup>Microbiology Department, Universidade Federal de Viçosa, Brazil

<sup>3</sup>EPAGRI, Florianópolis, SC, Brazil

<sup>4</sup>Associação de Produtores de Cogumelos de Florianópolis, Brazil

**Introduction**

The unemployment crisis in many countries and the opportunity to establish a new source of income are motivating a great number of small farmers around the world to consider mushroom production. The main reason for their interest is that mushroom crops enjoy higher profit margins and quicker returns than most other agricultural crops. Mushroom is also a healthy and nutritious food product that has become an important alternative source of dietary protein. Mushroom growing operations can be established as small family businesses and all together they can bring in important foreign currency when exported. For these and many other reasons mushroom production has become a very interesting activity in the rural areas of most developing countries.

Excellent conditions for mushroom production exist in Brazil, including a wide range of climates and a great diversity and availability of agro-industrial residues that can be used in the production of mushroom substrates. The major activities in the country are agro-industrial and residues are frequently wasted. Wasted materials include coffee residues, cereal straws, sugarcane bagasse, native and fast growing grasses, cotton plant leaves and stems and several types of industrial residues such as sawdust and manure. Most of these materials have already been tested and approved in other countries as suitable ingredients for mushroom substrates.

Several species of specialty mushrooms, *Lentinula edodes* and *Pleurotus* spp., have been recently introduced into Brazil by Asian immigrants. Even though *A. blazei* is a native Brazilian species, it was not until the 80's that cultivation of this species was established in the interior of the State of São Paulo from whence it has been extended to other states in the last decade.

This expansion of cultivation was stimulated by the high price of mushrooms on the international markets. The *A. blazei* species is also, at present, the most popular medicinal mushroom in Brazil.

**History of *Agaricus blazei* in Brazil**

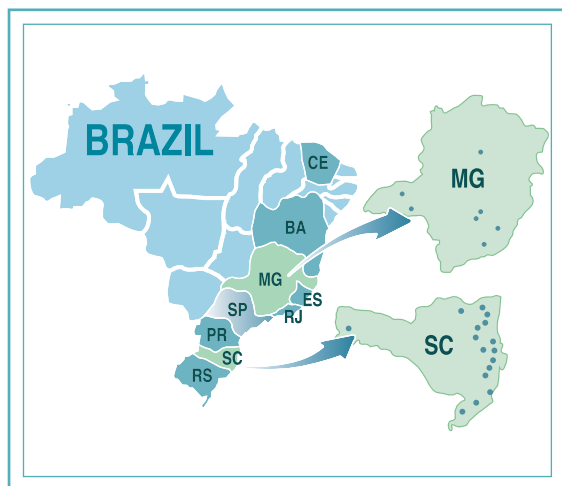
*Agaricus blazei* (Murrill) ss. Heinemann is known in Brazil as the medicinal mushroom, Cogumelo do Sol<sup>®</sup>, Cogumelo Piedade, ABM (from *Agaricus blazei* Murrill) or Cogumelo Blazei. Farmers from Piedade (interior of the São Paulo State) reported that the mushroom was sent to Japan in the 60's for research on its medicinal properties and after the benefits were known, the Japanese brought to Brazil the knowledge concerning the culture of the mushroom and established commercial mushroom farms in Brazil. Production for exportation to Japan was feasible because the climatic conditions in Brazil were favorable and because the commercial interactions with immigrant farmers were easy. At that time the commercial product of ABM mushroom farms was mostly dried mushrooms consumed as a health promoter with immuno-modulatory proper-

<sup>1</sup> *Agaricus blazei* (Murrill) ss. Heinemann, widely cultivated nowadays, was lately described as *Agaricus brasiliensis* by S. Wasser et al.

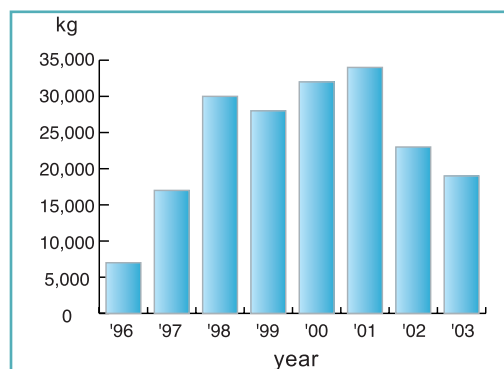
ties.

At present, the production areas have expanded to other states such as Minas Gerais (Southeast), Paraná, Santa Catarina and Rio Grande do Sul (South) as well as to some of the Northeast States such as Bahia and Ceará (Fig. 1).

Exportations of ABM sharply increased from 1996 to 1998, were steady until 2001, but in the last two years these exportations have decreased due to competition with other producers and the economic crisis in Japan (Fig. 2).



**Figure 1.** Regions in Brazil where *Agaricus blazei* has been cultivated. **SP**- State of São Paulo main national producer; **MG** and **SC**- detail showing farming localities in states of Minas Gerais (MG) and Santa Catarina (SC); **RS**-Rio Grande do Sul; **PR**-Paraná; **RJ**-Rio de Janeiro; **ES**-Espírito Santo; **BA**-Bahia; **CE**-Ceará



**Figure 2.** Brazilian exportation of *Agaricus blazei* from 1996 to 2003

Brazilian ABM mushroom growers export to a variety of countries including Australia, Bolivia, Germany, South Africa, Thailand, the USA, India and Korea. At the same time as exportations have decreased there has been noticed an improvement of the local market, as the Brazilian population has become more aware of the mushroom's benefits.

Mushroom consumption in Brazil is low, at about 30g/year/capita, when compared to other countries such as France and Italy which have consumption values of 2.0kg and 1.3 kg/year/capita, respectively. The first species cultivated in Brazil was *Agaricus brunnescens*, the champignon. Sixty percent of the national champignon crop is consumed fresh.

## Cultivation Technology of *Agaricus blazei*

### Locations and climate

In Brazil, ABM has been cultivated in regions close to the Atlantic coast, of moderate to warm temperatures and of high humidity, from September to April. It is cultivated mostly as a seasonal crop in farms with a low to medium technology profile. Average farmers cultivate 3-5 tons of compost any growing season.

Temperature is a very important ecological factor in ABM growth and fruiting. Optimal temperatures are higher than those maintained for champignon cultivation. ABM is a subtropical species and requires temperatures of 25-28°C for optimal mycelial growth and 22-25°C for fruiting. The species is very sensitive to extreme temperatures out of the optimal range, which is a factor contributing to the regional and seasonal restrictions on cultivation. Farmers in regions where summer temperatures are higher than those in the optimal range have a tendency to have lowered yields due to the faster development of pathogens. In regions of low temperatures, productivity has a tendency to be lower, with a frequent absence of fruit body production, unless environmental controls are used.

### Strains

Strains in Brazil vary in characteristics such as mycelial growth rate, optimal temperature for mycelial growth, optimal pH of substrate, fruiting body morphology and productivity. However, low genetic variability may, in a short period of time, make the crop susceptible to the pathogens and pests that are the common causes of low productivity. A frequent exchange of compost and spawn among different states has also facilitated the rapid spread of diseases and pests. A degenerated strain with low productivity was identified by Neves (2003), and even though variability among strains was low, important

traits may have been involved in genetic changes.

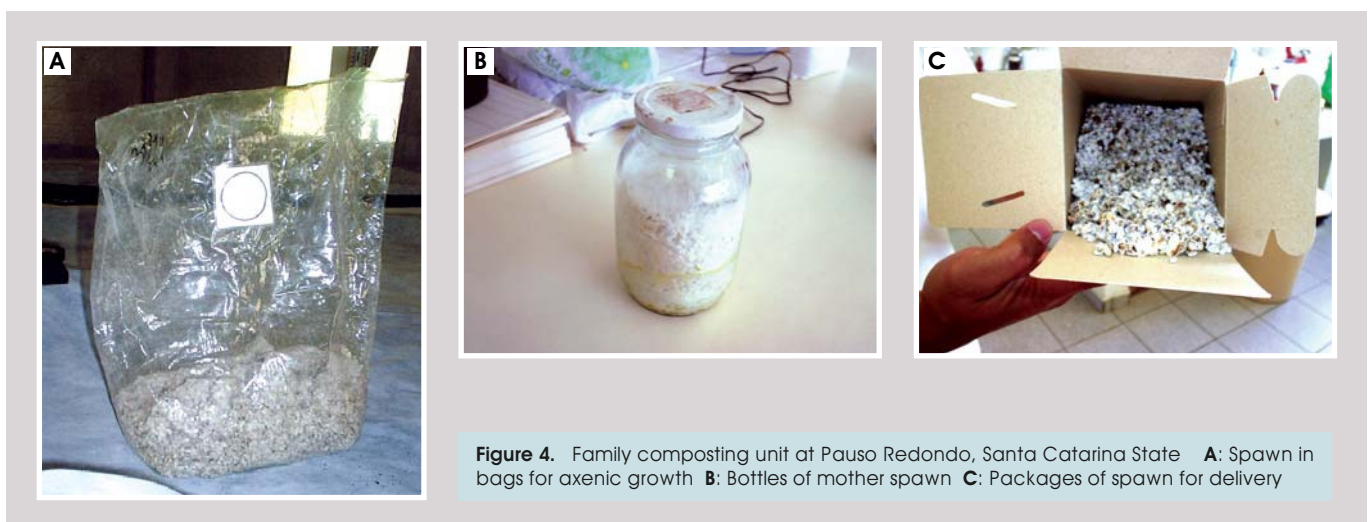
Selection experiments performed under laboratory and greenhouse conditions have been recently performed in commercial scale experiments. The strains UFSC 51 (Figs. 3) and 52 are in the experimental phase in several farms in the State of Santa Catarina for an evaluation of their productivity under different seasonal productive systems.

### Spawn



Spawn may either be produced commercially by private enterprises or be available from government or educational institutions.

Several spawn production technologies (solid-state fermentation or liquid fermentation) are being tested as well as different storage conditions, culture preservation methods and also containers for spawn production and storage (Figs. 4A and C). Mother spawn is available at the university laboratory for spawn manufacturers (Fig. 4B)



### Substrates

A small number of compost production units are established in Santa Catarina. Most of the substrate formulations used in the state are composed of corncobs, wheat and rice straws, or one of several other grasses.

Table 1 shows the substrate formulations used in Brazil – *A. brasiliensis*. In São Paulo State (sugarcane bagasse based). There are several compost production units at São Paulo State where the same compost for champignon is also used for *A. blazei*. The composting process involves a traditional fermentation (Phase I) followed by a pasteurization operation (Phase II) (Figs 5A, B and C).

**Table 1.** Sugarcane bagasse compost<sup>2</sup> formulation for *A. brasiliensis*

INGREDIENTS	WET WT(kg)
Sugarcane bagasse	3,000
<i>Brachiaria</i> sp. (grass)	1,500
<i>Panicum</i> sp.	1,500
Soybean bran	150
Urea	75
Ammonium sulphate	50
Phospahte	13
Gypsum	200
Calcarium	200
Water	7,700

Source: Eira, 2003

Compost is sold commercially either already inoculated and colonized or non-inoculated. Most farmers prefer the non-inoculated system and they inoculate with their own selected strains. Inoculation and spawn run is usually performed by the farmers at their growing houses as observed in Figure 5D. Spawn run usually takes 15-20 days depending on climate conditions. During the mycelial growth ventilation is minimal and the growing houses are maintained at temperatures of around 25-30 °C, with a humidity 80-85%.



**Figure 5.** Composting unit in State of São Paulo **A:** Storage area of composting materials **B:** Fermentation area (phase I) **C:** Pasteurization room **D:** Compost inoculated at farmers growing house

<sup>2</sup> C/N=37/1

### Casing

The different casing mixtures used include soil and sand, that are solarized or pasteurized for 6 hours in steam at 60-65 °C, and peat based mixtures. The high incidence of soil borne contaminants, particularly nematodes and fungal pathogens has made clear the need to avoid soil and find substitute non soil-based mixtures. The State of Santa Catarina has an extensive area of peat and the university is involved in a research project to define a better peat based substrate for casing. Several mixtures are being tested involving different degradation stages of peat. Casing is applied when the mycelium spreads into 75% of the compost. Depth of the casing ranges from 3 to 5cm, depending on the environmental variability of the growing house. Mycelium spreads within the casing layer in about 15 days. The whole growing cycle requires around 20-21 days from casing to the first harvest. The subsequent harvesting periods (usually 2-3 flushes) may require an additional 30-60 days depending on environmental conditions.

### Fruiting

Fruiting is induced by providing fresh air or ventilation (opening windows, use of exhausting equipments), lowering the temperature below 25 °C, and providing enough air humidity (use of evaporative cooling, irrigation of growing houses floor and walls) and performing heavy irrigation of the substrate. The elimination of CO<sub>2</sub> (ventilation+substrate irrigation) is then an important factor in successful induction. In rare cases, growers have sophisticated climate control systems. Between flushes the mycelia are left to recover for some days and during this resting period irrigation is maintained at a minimum level.

### Harvesting and processing



**Figure 6.** Harvesting and processing steps **A:** Collected mushrooms and eliminating soil particles **B:** Washing and brushing to eliminate cap pigment **C:** White mushrooms before drying process **D:** Introduced into the dryer

Mushrooms are harvested when they reach their highest biomass, which occurs during the immature stage (button stage with veil membrane enclosing the gills intact) as seen in Figure 3B. Several processing phases follow the harvest, such as

washing, brushing, selection, sanitization, sectioning, anti-oxidant treatment, drying, packing, selecting and storage (Figs. 6). Mushrooms are finally classified according to market standards as grade A, B or C, using as criteria the mushroom color (straw color, pale yellow), morphology and size.

### Growing conditions

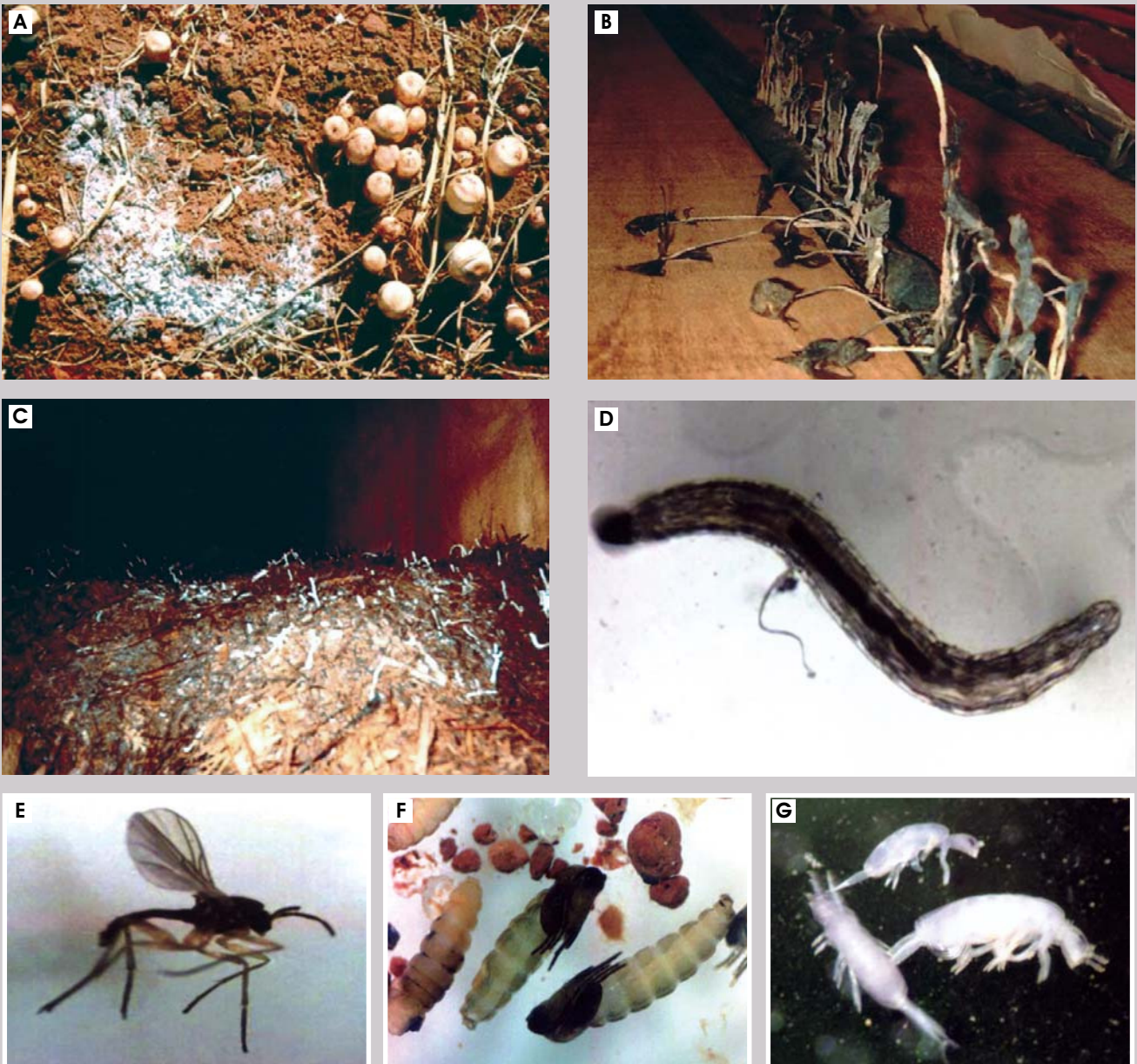
Seasonal cultivation in Santa Catarina is mostly done indoors, and undertaken either in plastic, wooden or brick houses (Figs. 7). Most of the farmers have no equipment for climate control. However a few have simple cooling systems (evaporative systems) or simple heating systems built by the farmer. The average size of a house ranges from 90 to 120m<sup>2</sup> ranging from 6 × 15 × 3.5m to 8 × 15 × 3.5m.





**Figure 7.** Growing conditions: under growing room conditions **A-D:** Different types of growing houses **E:** Outdoor **F,G:** A growing house made by plastic **H:** Beds and **I:** Trays

**Pests and Diseases**



**Figure 8.** Important diseases and pests in the State of Santa Catarina **A:** *Trichoderma* sp. **B:** *Coprinus* sp. (bellow substrate bed) **C:** *Coprinus* sp. on the substrate **D:** *Lycoriella* larvae **E:** *Lycoriella* sp. **F:** *Lycoriella* pupae stage **G:** *Collembola*

Main problems in cultivation of *Agaricus blazei* are caused by insects (*Lycoriella* sp.) and fungus contamination (as the “false truffle” (*Diehliomyces* sp.), *Coprinus comatus*, *Trichoderma* sp., *Chaetomium* sp. and *Papulospora* sp.), indicators of low quality compost.

Parasitic fungi occur often in farms with inadequate management techniques. Non-disinfected casing layers and other poor hygiene and non-existent prevention practices lead to many parasitic fungi problems.

The most serious fungal disease diagnosed in SC was the “false truffle” in 1999, that was responsible for heavy losses (50-80% loss of production) in several farms in the regions of Jaraguá do Sul and Benedito Novo, in the northern region. The source of contamination was inadequately composted substrate introduced from another State.

Pests are often responsible for even heavier losses. Sciaridae flies frequently infest most farms. Phoridae have been present less frequently than *Lycoriella*, and *Collembola* was found in several farms but losses were reduced after the introduction of controlling measures. Mites and nematodes may occur after the first flush if the farmer does not use preventative measures.

Since this mushroom cultivation is still a recent phenomenon in the state, it is possible that the incidence of diseases will increase in the future. However, farmers are being educated in programs that teach them how to prevent serious problems and avoid the need for pesticides.

Few pesticides have been used in the mushroom farms in Santa Catarina because most farmers sell their dried mushrooms for higher prices to consumers who are concerned about the use of pesticides. The most commonly used pesticides, for the control of flies, are Decis (deltamethrin) and Dimilin (diflubenzuron).

### Production and Products of *A. blazei*

There are no official statistics on the country's mushroom production but it is estimated that total production is around 3,000 tons per year (0.12% of world production), involving around BRL<sup>3</sup> 10 million (USD3.6 millions). The State of São Paulo, Região do Alto Tietê, is the biggest producer of mushrooms in the country, and accounts for 70-80% of the national production.

Brazil is not a significant participant in the world mushroom market because the national production is so low. Part of the local demand, mostly for champignon, is supplied by importations from different countries, such as Chile, China, India and Indonesia. From 1997 to 2000 the exportation volume was significantly inferior to the volume of importations. However, whereas importations involved species of consumed fresh, as the champignon, with low economical value, exportations involve dried, sliced or powdered mushrooms, mostly *A. blazei*, that is a high valued product in the market. As a result, the commercial balance of mushroom activity in Brazil has been extremely positive due to the production of *A. blazei* for export.



**Figure 9.** Biotecnological products made with *Agaricus blazei* mushrooms commercialized in Brazil **A:** Supplements **B:** Cosmetic products (Photo courtesy of Renata May)

<sup>3</sup> BRL (Brazilian Real, USD1 = BRL 2.8 in March, 2005)

## Cost and benefit of *Agaricus blazei*

Productivity as measured as a wet weight of mushrooms compared to the wet weight of the substrate used varies between 5 and 20%. Most farmers average a ratio of 10%. Mushroom prices are quite variable, depending on the region, the season and the production technology, with values ranging from BRL80.00 (USD28.57) to BRL200.00 (USD71.43)/kg of dried mushrooms (average price type A is BRL140.00 (USD50)). Farmers' profits are also quite variable, particularly if external marketers are used, and may reach values from 42.6% to 74.8%.

Cost and benefit of *A. blazei* mushroom production (for 3 months up to 3 flushes) in a farm with a seasonal production in a simple 120m<sup>2</sup> growing house, with 5,000kg of compost.

Based on 1% productivity (average)					
Content	Unit	Quantity	Unit value	Amount in BRL	
Mushroom Type A	Kg	25	200.00	5,000.00	
Mushroom Type B	kg	25	120.00	3,000.00	
Re-sale of compost	kg	5,000	0.12	600.00	
<b>Total revenue (A)</b>				<b>8,600.00 (USD3,071.43)</b>	
<b>Variable costs</b>					
Compost	kg	5,000	0.65	3,250.00	
Silica gel	bags 25g	100	1.20	120.00	
PPL bags	kg	1	10.00	10.00	
Pit casing layer	bags 25kg	50	7.00	350.00	
Cleaning chemicals	1	4	2.50	10.00	
Electricity	kw/h	700	0.50	350.00	
Water	m <sup>3</sup>	2.5	2.50	6.25	
Labour	days	72	25.00	1,800.00	
Freight	unit	3	100.00	300.00	
Tax (2.3% on A)	%	2.3	8,600.00	197.80	
<b>Total variable costs (B)</b>				<b>6,394.05 (USD2,283.59)</b>	
<b>Gross margin (A-B)</b>				<b>2,205.95 (USD787.84)</b>	
<b>Fixed costs</b>					
<b>(based on an investment of BRL 18,422.00 for 120m<sup>2</sup> growing house a dryer and washing facilities)</b>					
Repairs and maintenance	%	1	18,422.00	46.06	
Depreciation on buildings	%	4	18,422.00	184.22	
Depreciation on machines	%	10	18,422.00	460.55	
Interest on capital (6%/yr)	%	6	18,422.00	276.33	
<b>Total fixed costs (C)</b>				<b>967.16 (USD345.41)</b>	
<b>Total cost of production (B+C)</b>				<b>7,361.21 (USD2,629.00)</b>	
<b>Net profit</b>				<b>1,238.80 (USD442.43)</b>	
<b>Sensitivity analysis</b>					
	<b>Total revenue</b>	<b>Variable cost</b>	<b>Gros Margin</b>	<b>Fixed cost</b>	<b>Profit</b>
1% productivity	8,600.00	6,394.05	2,205.95	967.16	1,238.79
1.5% productivity	12,600.00	7,345.43	5,254.57	967.16	4,287.41
2% productivity	16,600.00	8,069.30	8,530.70	967.16	7,563.54
<b>Benefit / Cost analysis</b>	<b>Benefit</b>		<b>Cost</b>		<b>B / C</b>
1% productivity	8,600.00		7,361.21		1.17
1.5% productivity	12,600.00		8,312.59		1.52
2% productivity	16,600.00		9,036.46		1.84

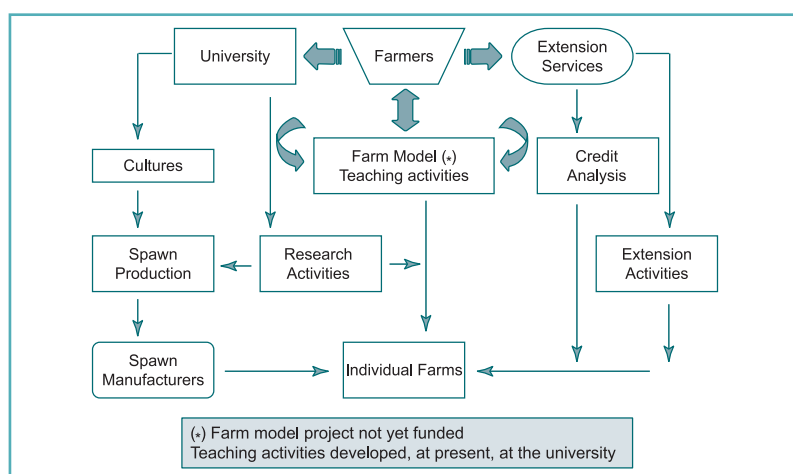
## Perspectives for Low Income Farms in Developing Countries

Good profits are usually obtained when farmers have access to good quality spawn and compost and also have the basic knowledge of culture management. There is no need for sophisticated growing houses or technologies in order to generate a profit with seasonal production systems. However, the availability of these basic ingredients for success occurs only when cooperative relationships between governmental institutions and farmers are established.

As Brazil is an extensive and diverse country with different agro-climatic regions, with great differences in the types of residues available for substrate production, cultivation technologies must be selected regionally. Furthermore, each state has its own priorities that are defined by governmental programs which are established periodically. The State of Santa Catarina, in South Brazil, has defined mushroom cultivation as one of the priority crops in the agricultural program of the State in 2004. A previous successful experience in the cultivation of ABM mushrooms occurred in 1999, in Garuva, Northern of Santa Catarina and the model for the present governmental project was set up. At present the project has been extended to several regions of the State and was improved with the participation of an association of farmers.

Based upon the program, technologies and research should be developed at universities and extended to the farmers through competent extension services. Knowledge should be transferred in programmed educational processes which should integrate scientists, extension experts and farmers. Successful cultivation should depend upon permanent organizations of support, such as a clinic for the diagnosis of problems, particularly pests and diseases, and a model farm to perform educational courses, where key production steps should be performed.

Farmers should be organized (in associations or cooperatives) and linked to governmental institutions (universities, extension services) so they can have competent support and apply efficiently to governmental funds.



**Figure 10.** Interactions between farmers and governmental institutions in the State of Santa Catarina

As scientific and technological research on ABM improves, profitability will increase and risks on cultivation will be reduced. The species, being adapted to high temperatures, is very interesting as an alternative for developing countries, to improve the amount of protein in the diet (mushroom has around 49% protein, high protein content) and also to reduce poverty (high price in the international market).

If seasonal cultivation is selected, low investments on infrastructure are required. However, success is dependant upon some type of technical support for cultivation and marketing particularly if foreign markets are targeted.

According to Eira (2003) attention should be paid to avoiding the main causes responsible for a decrease in farm profits. The causes include:

- Low quality compost, spawn and casing layers
- High incidence of pests, diseases and contaminants
- Environmental factors not managed according to the species requirement
- Late harvesting that results in low quality products
- Low market prices due to lack of good marketing strategies

## Conclusion

*Agaricus blazei* is an interesting alternative to developing countries because:

It is a versatile mushroom and has multiple uses including medicinal, cosmetic and food use. It has a high level of protein so it may be used as a nutraceutical (functional food). Consumption and cultivation promotes health in the population. Cultivation of ABM contributes to sustainable agriculture efforts by making use of agricultural residues. Has relatively high price in the international market. It is economically viable to cultivate ABM if three basic factors are considered: use of quality spawn, compost and good culture management. As the mushroom is mostly consumed dried it may be stored for long periods and there is no need to immediately commercialize the product.

## REFERENCES

- Chen, A. 2001. Cultivation of *Agaricus blazei* Murrill, a mushroom of culinary and biomedical importance. *International Journal of Medicinal Mushrooms* 1: 291-301.
- Cogumelos :mercado e comercialização. available at <http://www.faemg.org.br/>
- Eira, A.F. 2003. Cultivo do Cogumelo Medicinal, *Agaricus blazei* (Murrill) ss. Heinemann ou *Agaricus brasiliensis* (Wasser et al.). Editora Aprenda Fácil. Viçosa, MG. 395.
- Kopytowski Fo, J. 2002. Relação C/N e proporção de fontes de nitrogenadas na produtividade de *Agaricus blazei* Murrill e poder calorífico do composto. Dissertação de Mestrado, Universidade Estadual Paulista Julio de Mesquita Filho, Campus Botucatu. 96p.
- Nascimento, J.S. 2003. Etiologia, controle e demanda de energia na prevenção da falsa trufa (*Diehliomyces microsporium*) em cultivos de *Agaricus blazei*. Tese de Doutorado, Universidade Estadual Paulista Julio de Mesquita Filho, Campus Botucatu. 114p.
- Neves, M.A. 2000. Caracterização ecológica, fisiológica e genética de *Agaricus balzei* Murrill através de estirpes provenientes de diferentes empresas de produção de cogumelos. Dissertação de Mestrado, Universidade Federal de Santa Catarina. 69p.
- Wasser, S.P., Didukh, M.Y., Amazonas, M.A. de A., Nevo, E., P. Stamets, and Eira, A.F. 2003. Is a widely cultivated culinary-medicinal Royal Sun *Agaricus* (the Himematsutake mushroom) indeed *Agaricus blazei* Murrill? MushWorld website. available at <http://www.mushworld.com>

## Part II Mushroom for Better Life

## Chapter 8

Mushroom for a Living**SMALL SCALE OYSTER MUSHROOM CULTIVATION IN EGYPT**

Ahmed Badr

Pest management Department Tanta. Agricultural Difectorate, Egypt (abptcedu@hotmail.com)

**Introduction**

Figure 1. Map of Egypt

Many parts of the world, particularly developing countries, have a problem in producing sufficient food, and poverty is increasing rapidly in these areas. There is a great need for tools to alleviate this poverty, and one of these tools is the growing of mushrooms. This poverty alleviation tool is particularly appropriate in countries that have large amounts of agricultural wastes. According to the mushroom growing guide published by the ministry of agriculture in 2003, Egypt is one of those countries having large unused agricultural wastes, and produces over 30 million tons of agricultural wastes every year. These wastes include rice straw, wheat hay, maize and cotton refuse, sawdust, vegetable residuals (mainly potato, tomato, and peanut), sugarcane trash, industrial food wastes, and water hyacinths.

Mushroom cultivation turns this refuse into a food source rich in minerals, protein, carbohydrates, and other healthy compounds. The material that remains after mushroom cultivation can be used as animal

fodder. Mushroom cultivation also offers employment to youth in rural regions. Mushroom cultivation provides an inexpensive protein source. While meat as a protein source is expensive (EGP<sup>1</sup>28-30/kg, USD4.48-4.8) for those who have a limited income, oyster mushrooms are so inexpensive (EGP9-12/kg, USD1.44-1.92), that they are called "Poor Man's Meat." Current dietary habits in Egypt do not include the consumption of mushrooms. For the promoted consumption of mushrooms, considerable efforts are required.

Mushroom cultivation is a suitable activity for the climate in northern Egypt where the temperature is 15-20°C in winter and 25-35°C in summer. Potential mushroom cultivation substrates are abundant in the countryside, where rice, wheat, maize, and cotton are commonly cultivated in the Delta provinces. Most parts of Egypt, except southern Egypt with hot and dry climate, have a climate appropriate for the cultivation of mushrooms.

The effort to promote mushroom cultivation among small farmers requires only simple kits and treatments, and all of the basic components needed to establish a mushroom cultivation industry are in place. Mushroom cultivation activity is beginning to increase, but is still far from being a mature industry.

Oyster mushrooms are the most commonly cultivated type of mushrooms in the areas where rice straw can be obtained for free from farmers. These rice farmers otherwise burn any excess rice straw in the fields at the end of summer in order to clear the fields for the next crop. The climate from September to April is suitable for cultivating oyster mushrooms. Many people grow oyster mushrooms in home kitchens in areas where the mushrooms are not available in the local markets.

<sup>1</sup> EGP(Egyptian Pound, USD1 = EGP6.25 in March, 2005)

### Short history of mushroom cultivation in Egypt

Mushrooms were known more than three thousand years ago by the ancient Egyptians. They were considered a luxury food, were eaten only by the nobility, and known as the food of the gods. In the 1940's some European foreigners living in Egypt cultivated mushrooms on a very small scale and collected wild mushrooms during the winters. In the 1980's the mushroom cultivation farms were established in Tanta and Faqous could not satisfy the demand from the hotels, tourists, and local residents.



**Figure 2.** Oyster mushroom in growing house  
(Photo courtesy by Dr. Amira Ali El-Fallal)

Studies on mushroom cultivation began in 1984 at the Fungi Identification and Preservation Laboratory in the College of Agriculture at Ein-Shams University. This organization concerns itself with the identification of wild mushrooms in Egypt and the cultivation of *Pleurotus* species such as *Pleurotus ostreatus*. They also do research on the use of agricultural wastes such as cereal straw, cotton and maize waste, wood, and sawdust. The study on commercial cultivation began in 1988, when several universities and food technology institutes established research units that are responsible for training growers in mushroom cultivation and marketing. These agencies provide low cost cultivation kits and spawn, and marketing assistance for growers. Today information about mushroom cultivation (especially oyster mushrooms) is available to small farmers through the agriculture directorates of all of the provinces in Egypt.

## Oyster Mushroom Cultivation in Egypt

### How to cultivate

There are three main methods used in Egypt for cultivating oyster mushrooms commercially and one other method used in house kitchens as a hobby. The most frequently used substrate material is cereal straw, although rice strow costs the least.

The clean and dry straw is selected from the field and then cut into smaller pieces (although some farmers do not cut the straw because many rice species in Egypt have short stems), packed in plastic bags, soaked overnight, then let stand for 10-15 hours in order that the excess water can drain off. Then the substrate is boiled or steamed in a metallic drum using a heating source such as kerosene, firewood, or gas cylinders. The heating is continued until the temperature reaches 100°C. This process takes one or two hours. Some additives are applied to before or after pasteurization, these additives usually include 5% wheat bran and 5% lime, although some growers use gypsum.



**Figure 3.** Soaking straw  
(Photo courtesy by Dr. Amira Ali El-Fallal)

The temperature and humidity level of substrate are 25-30°C and 70-80%. Growers commonly pack the substrate in polyethylene bags, plastic vegetable netting, or rigid plastic cylinders

The polyethylene bag method is one of the easiest methods, and is especially appropriate for beginners. The bags are about 50cm wide and 80cm tall. Substrate and spawn are added in alternate layers, with the substrate layer being 10-15cm thick and the spawn layer sprinkled on top and concentrated near the outside edge. The bags are then closed and arranged on top of bricks placed on the floor. The inoculated bags are then incubated.

When using the plastic vegetable netting method, a cylindrical skeleton constructed of metal wire or bamboo is prepared to hold open the netting. The netting has a radius of 30cm and pieces 70-80cm in height are used. The substrate and spawn are arranged in layers as in the polyethylene bag

method. The resulting blocks are covered with plastic and incubated.

The method that uses plastic cylinders makes use of pieces of Simi hard plastic that are closed to make cylinders of 35-40cm radius and 1.5-2m in height. The prepared substrate is mixed with spawn on a clean plastic sheet, the cylinders filled with spawned substrate, and then they are covered with a plastic sheet and incubated.

For all the three methods (bag, block, and cylinder) the inoculated substrate is arranged in a warm dark place. The incubating material is protected from insects and wild animals and aged for 2-3 weeks depending on the season and temperature, incubating until the substrate is coated with a white mycelia. Holes are made in the plastic sheets cover to allow venti-

lation and permit excess water to drain away. In the subsequent production stage, optimum conditions include a temperature in the range of 18-20 °C and relative humidity above 90%. Good ventilation should also be maintained.

In the common kitchen method plastic boxes are arranged in stable columns. In each box a substrate layer 10-15cm deep is packed, then spawn is sprinkled on the surface, followed by another 5-10cm deep substrate layer. The columns of plastic boxes are then covered with plastic and incubated.



**Figure 4.** Oyster mushroom in the bag  
(Photo courtesy by Dr. Amira Ali El-Fallal)

### Mushroom growers; spawn supply, and production marketing

There is no exact number of oyster mushroom producers recorded because most of them are seasonal. Growers are mostly located in the provinces of Giza, El-Sharqiya, El-Gharbiya, and Kafr El-sheikh. Rice and wheat cultivation is most common in El-Gharbiya and Kafr El-Sheikh provinces. None of the growers produces their own spawn. Companies that sell mushroom growing kits do not produce their spawn on agar plates because they don't have the required technical laboratories. The spawn producers merely inoculate grains from another grain spawn, using grain to grain transfer, usually on wheat grains. Spawn from PDA or PDYA media is only found at the universities and research institutes laboratories such as the Food Technology Research Institute, Alexandria University, Minufiya University, and Ein-shams University. Ein-shams University works with strains imported from German, Italian, and Dutch laboratories such as those on the list below:



**Figure 5.** Spawn in the bottle and bag  
(Photo courtesy by Dr. Amira Ali El-Fallal)

- |                                 |  |
|---------------------------------|--|
| 1. <i>Pleurotus ostreatus</i>   | 7. <i>Pleurotus eryngii</i>                |
| 2. <i>Pleurotus florida</i>     | 8. <i>Pleurotus flabellatus</i>            |
| 3. <i>Pleurotus colombinus</i>  | 9. <i>Pleurotus michigan</i>               |
| 4. <i>Pleurotus sajor-caju</i>  | 10. <i>Pleurotus saca</i>                  |
| 5. <i>Pleurotus pulmonarius</i> | 11. <i>Pleurotus salmoneo – stramineus</i> |
| 6. <i>Pleurotus cornucopia</i>  | 12. <i>Pleurotus sapidus</i>               |

The demand for oyster mushroom is high from September to April because of Christian fasting practices. People favor oyster mushrooms as a cheap vegetarian protein source rich in amino acids during their fasting. The main customers are normally hotels, supermarkets, and restaurants. Growers do not generally sell the mushrooms themselves. The growers sell their crops to marketing companies, and it is these companies that provide growing kits and spawn for the growers.

### Costs and Benefits from Oyster Mushroom Production

The main initial costs in the mushroom cultivation business are the building expenses. Egyptian growers use garages, store-rooms, or other locations that have a solid floor, walls, and a roof. Growers in Egypt rarely use greenhouses or similar structures.

The economic benefits of oyster mushroom cultivation should include a calculation for production rental expenses. One ton substrate needs about 25m<sup>2</sup> and the farmer may cultivate it himself or they may use one worker (Table 1). The average mushroom production is about 20-25% of the prepared substrate dry weight. Every 1kg spawn can result in 5kg of fruiting bodies. From 3 tons of substrate a farmer may harvest 600-750kg of mushrooms over a three month period. The price per kg is EGP6 or marketing companies. Farmer income from mushroom sales is EGP3,600-4,500 (USD576-720).

**Table 1.** Total expenses for 3 months

No	Expense Contents	Quantity	Amount(EGP)
1	Substrate; one ton hay, moisturized and pasteurized so it becomes three tons		200
2	Spawn; from mushroom unit, Ein-shams University, add with 5%	150kg ×EGP6	900
3	Containers; bags, nets, boxes, or cylinders (depreciation rate)		150
4	Place (if rented)	EGP100 ×3 months	300
5	Laborer (one)	EGP150 ×3 months	450
6	Disinfectants		50
7	Water and electricity		50
8	Packing and transportation for marketing		100
Total expenses			EGP2,200 (USD352)

Total profit = total income – total expenses

= 3,600-2,200 = EGP1,400 (USD224 at minimum) or = 4,500-2,200 = EGP2,300 (USD368 at maximum)

This profit can be maximized if place and substrate are free.

## Conclusion

Cultivating oyster mushrooms in Egypt is an effective method to alleviate poverty. Spawn and production materials are available in free and low cost arrangements. Substrates such as rice straw and cotton wool are often free for the taking. Good quality spawn is supplied by Mushroom Laboratory under the Egyptian Ministry of Agriculture at low cost, and during governmental projects the spawn is supplied for free. The weather in Egypt from September to May is suitable for oyster mushroom production and the temperature is easily controlled. During the hot summers, mushrooms such as straw mushrooms may be cultivated. Marketing is often done through the organizations that supply spawn, or through contracts with marketing companies for larger production amounts.

Production costs could be further minimized and net profit for farmers maximized. Rural residents need only to acquire the knowledge and training to set up their own small mushroom business. By this means they could earn money and improve their hygiene and diet. Oyster mushroom cultivation is a powerful remedy for many problems, as it prevents pollution caused by burning agricultural wastes, and instead turns those wastes into healthy food source. This cultivation activity also helps to alleviate poverty by allowing small farmers to sell mushrooms. Finally the spent substrate becomes animal fodder or organic fertilizer after it is composted.

## Part II Mushroom for Better Life

## Chapter 9

Mushroom Growing Project

## PILOT MUSHROOM CULTIVATION PROJECT IN NEPAL

Clare Murray

The Esther Benjamins Trust, The Business Village, 3-9 Broomhill Road, London SW18 4JQ, The U.K. (ebtrust@hotmail.com)

## Project Outline

Duration	August 2004 (ongoing)
Location	The Makwanpur District
Goal	Rehabilitation of circus returnees by vocational training that will benefit themselves, their families and the community as a whole
Beneficiary Groups	Circus returnees and their families
Participating Organizations	The Esther Benjamins Trust, The Nepal Child Welfare Foundation

## Background

### Rescue

The plight of hundreds of children who were trafficked from Nepal to India to work in the circuses came to our attention in 2002 when the Esther Benjamins Trust commissioned the first undercover survey into the problem. The research then and subsequently conducted revealed that over 300 children, mostly Nepali, mostly girls and some as young as five were trapped as circus performers under illegal contracts. The children described the terrible conditions inside the circuses and the long hours they were made to work rehearsing and performing often dangerous acts. They received little food, no healthcare and no education, suffering physical and sexual abuse. The Esther Benjamins Trust (EBT) alongside our partner organisation, The Nepal Child Welfare Foundation (NCWF), was helping to return these lost children and young people to their homes and provided the support and training to enable them to reintegrate into society. The EBT aimed to see the end to the use of child performers in Indian circuses by 2007.

In addition to the children and young people that EBT and NCWF helped to bring back to Nepal there were many circus performers who returned to Nepal on their own at the end of their contracts, whom EBT and NCWF also support. All of the circus returnees found it extremely difficult to settle back into life in Nepal as they were stigmatized as 'show girls' and they were unable to earn an income as they had no skills beyond those learned in the circus. Most of the returnees were from the Makwanpur District which is one of the prime trafficking areas in Nepal and also one of the poorest parts of the country.

### Rehabilitation

The EBT offers education and a return to schooling for younger circus returnees and recognises the need to offer older



Figure 1. Nepalese girls performing stunts in an Indian circus

returnees training in sustainable skills that will provide them with the opportunity of long term employment which will benefit themselves, their families and the community as a whole.

This paper discusses the objectives and goals behind the mushroom cultivation pilot project as well as the process of establishing a training center, and the evaluation of the pilot project for future courses.

## Mushroom Cultivation

### The viability of mushroom farming



Figure 2. Map of Nepal

The Makwanpur District is located where the low lying Terai region of Nepal meets the start of the hill region. Many varieties of edible mushrooms are found in a wild state in the Terai lowlands, the hills and mountains of Nepal (Cozens, 2004). Through research it was learnt that the region was suitable climatically to grow mushrooms and especially the *Pleurotus* spp. (oyster mushroom) and *Volvariella* (paddy straw mushroom) which grow easily during most seasons (Cozens, 2004).

Mushroom cultivation in this part of Nepal is an economically viable skill because there is minimal input required due to the low cost of spawn and agricultural waste, and the activity generates a good financial return. Mushroom farming is not labour intensive and does not necessitate a large amount of land; it can be done in conjunction with other types of farming, such as goat herding or chicken farming increasing the amount of income generated. Mushrooms are a good source of protein, minerals and some vitamins. In order to supplement

the diet of the farmers, who may not be able to afford nutritious meals for themselves and their families, they are able to eat a portion of the mushrooms grown.

### The suitability of mushroom farming for the beneficiary group

There are over 150 circus returnees who have been identified, whose ages range from 6 to 42. Most of the returnees are female with only 11% being male and many have home commitments that mean they need to learn a skill they can use from home.

Mushroom cultivation is ideal for this group as they can transfer the skills learned to their homes where they will still be able to fulfil their other commitments. In the past the girls have suffered discrimination and harassment due to their history but as mushroom farmers, whose produce is sold they will become the main income earners in many of their families and they will gain the respect of others in society.

### Objectives

The mushroom cultivation course aims to teach the returnees skills that will enable them to participate and be strong competitors in society. The skills are those that they can use in their own homes and villages and/or in a planned central production center through which they can become self-sufficient, financially independent, and contribute to relieving the financial hardship in their communities. In this way the returnees will regain the self-esteem and confidence that they lost through the harsh treatment in the circuses and since their return to Nepal.

## Project Planning

### Overview of the process

EBT and NCWF planned the course and project on a number of levels. Initially the EBT Director, Philip Holmes discussed mushroom farming with the staff at EBT and with the NCWF Director, Khem Thapa. Clare Murray of EBT researched mushroom farming by contacting organisations involved with mushroom farming and small business initiatives. She contacted MushWorld who forwarded details of mushroom experts in Nepal and sent the informative 'Mushroom Growers' Handbook 1: Oyster Mushroom Cultivation.'

It was necessary to ensure that an idea which was put forward in a meeting in an office in London, UK would be viable on the ground in Nepal and a skill that the circus returnees would want to take up. Therefore on a visit to Nepal, Clare Murray discussed and researched the idea with NCWF staff in both Hetauda and Bhairahawa and the circus returnees themselves. The staff in Hetauda assisted in the market research of the area, the number of the participants, where the training center would be established, which members of staff would be involved and the logistics of the course.

**Table 1.** Initial investigatory phase of the project planning

Detail	Remarks
<b>Process: Negotiations</b>	
<ol style="list-style-type: none"> <li>1. Negotiations took place between EBT and NCWF to discuss whether mushroom farming was a viable option in Nepal and specifically in the Makwanpur District for the circus returnees.</li> <li>2. Discussions with the circus returnees took place to ensure mushroom cultivation was a skill that they wanted to learn and one which would be suitable to their needs.</li> </ol>	<ol style="list-style-type: none"> <li>1. It was necessary for all partners concerned to discuss the project and reach a consensus on the next stage so that everyone involved had the opportunity to express concerns and convey ideas right from the beginning.</li> <li>2. The requirements and opinions of the beneficiary group have to be the priority in all project planning to ensure the sustainability of the project.</li> </ol>
<b>Process: Research</b>	
<ol style="list-style-type: none"> <li>1. EBT carried out research of mushroom cultivation through the internet, reading publications and books.</li> <li>2. EBT undertook research in Nepal talking to mushroom experts to ascertain the viability of mushroom cultivation in the Makwanpur district.</li> <li>3. EBT researched the equipment needed to establish a training center and the cost involved.</li> <li>4. EBT and NCWF carried out market research in Nepal and the Makwanpur district.</li> </ol>	The project required research on all levels to ensure that all involved could be prepared before the courses started.
<b>Process: Partners</b>	
<ol style="list-style-type: none"> <li>1. EBT and NCWF worked together from the initial stages of project planning.</li> <li>2. MushWorld forwarded the contact details of a mushroom expert in Nepal called Dr. Manandhar. Initially she discussed the project idea with EBT and NCWF and offered her advice before becoming the trainer on the pilot course.</li> <li>3. MushWorld provided advice throughout the planning of the project.</li> </ol>	All partners involved in the project contributed their expertise to achieve a holistic approach to the project.
<b>Process: Beneficiary group</b>	
<ol style="list-style-type: none"> <li>1. The background of the circus returnees was taken into account so that any emotional support they might need should be provided.</li> <li>2. Any transferable skills that the project team could offer were used.</li> </ol>	Underlying all the planning was the emphasis on sustainability of the project necessitating the provision of practical and emotional support for the beneficiary group.
<b>Process: Feedback and monitoring</b>	
<ol style="list-style-type: none"> <li>1. Throughout the planning and implementation of the project the opportunity for the project team to comment and provide feedback was emphasised so that adjustments could be made.</li> <li>2. Monitoring of the project was required so that modifications could be made to ensure success of future courses and the long term viability of the project.</li> </ol>	<ol style="list-style-type: none"> <li>1. The beneficiary group should be given the opportunity to provide feedback. It is understood that the beneficiary group's circumstances will change over time and modifications will be made where necessary.</li> <li>2. Nepal's political situation is unstable and it was necessary to realise that if there was a deterioration of the situation, it might impede project implementation, necessitating flexibility in the project planning.</li> </ol>

### Market research and competition

EBT and NCWF established that initially the mushrooms would be sold to the local market in nearby towns such as Hetauda, Birganj (50km from Hetauda) and Chitwan (60km from Hetauda) and our research produced positive feedback from the local hotels and restaurants that due to the lack of fresh mushroom use canned mushrooms. They all said that they would be keen to buy fresh mushrooms from the returnees if they were available. They all emphasised the need for the mushrooms to be really fresh and this became one of the main concerns of the project since Hetauda, being on the edge of the low lying Terai, has a hot climate.

There are no other mushroom farms in the vicinity of Hetauda, so the Nawajagaran Cooperative, a cooperative which supports the return of circus girls and their rehabilitation, is in the enviable position of being able to produce mushrooms exclusively for the local market. It is commonly thought that mushrooms can only be grown in the winter in the Terai region of Nepal. While it is true that oyster mushrooms can only be grown from October to February in the Terai, shiitake mushrooms can be grown when the oyster mushrooms are not in season. There is thereby an almost year round production possibility.

### Project team

We devised a team who would manage the training center and project and offer long term support to the participants. They included:

#### Trainer

Dr. Manandhar, as a trainer for the course, devised the syllabus and training schedule. She also appointed a trained assistant who assisted with the training alongside Dr. Manandhar or alone when Dr. Manandhar thought it was suitable.

#### Assistants

Two NCWF staff were assigned to assist with the course at the same time as learning how to grow mushrooms ensuring that skills and responsibilities were transferred through so that course and project could be replicated and sustained in the future. They could also provide any support needed by the circus returnees.

#### Monitoring

EBT and NCWF took on the role of monitoring the project to ensure that any feedback from the circus returnees or trainers was taken on board and any modifications implemented.

Transferable skills that EBT or NCWF staff had were utilized; for example, a member of NCWF staff had a commercial background and in the market research stage of the project he contacted connections from his previous employment.

### The syllabus

Dr. Manandhar devised the syllabus which included:

- Pasteurization of substrate
- Inoculation of substrate and mycelium process
- Harvesting of mushrooms
- Nutritional and medicinal values of mushrooms
- Pest and disease management
- Post harvest management and drying methods
- Financial management
- Packaging, marketing and cooking

It was decided that initially spawn would be purchased since spawn cultivation is a more complicated process and requires more technical equipment. Spawn cultivation would be an advanced part of the course. The training center, however, will start to produce its own spawn eventually. The course syllabus was developed to be as well rounded as possible so that the participants might be trained in the financial management of the farm, understand the health benefits of mushrooms, and be able to market the produce and cook healthy meals for their families in addition to learning the skills of mushroom cultivation.



Figure 3. Dr. Keshari Manandhar giving a lecture at the opening ceremony

**Table 2.** Training schedule for circus returnees (Mushroom Cultivation Training Part I)

<b>Day 1</b> <b>September 23,</b> <b>2004</b>	Session I – Inauguration of the Training		by Dr. Keshari Manandhar
	10:30 - 11:00	Opening ceremony	Classroom
	11:00 - 11:30	Introduction of participants and others	Classroom
	11:30 - 12:30	Introduction of mushroom cultivation	Classroom
	12:30 - 12:45	Closing of the session I	Classroom
	12:45 - 13:30	Tea Break	
	Session II- Oyster Mushroom Cultivation		by Mr. Gokul Raut
	13:30 - 14:30	Method of oyster mushroom cultivation	Classroom
	14:30 - 15:00	Discussions	Classroom
	* Programme supervisor set up classroom for the whole training period. Snacks and tea were required. Mr. Indra Dahal arranged all necessary arrangements for the inauguration.		
<b>Day 2</b> <b>September 24,</b> <b>2004</b>	Session I - Practical Work		by Mr. Gokul Raut
	10:00 - 10:30	Chopping of straw and soaking in water	Mushroom Farm
	10:30 - 11:00	Theory on pasteurization of straws	Classroom
	Session II		by Mr. Gokul Raut
	11:00 - 11:30	Clean the straw and drain off water	Mushroom Farm
	11:30 - 12:00	Pest & disease management – theory only	Classroom
	12:00 - 12:30	Start pasteurization of straws	Mushroom Farm
	12:30 - 13:30	Pasteurization continues and tea break	Classroom
	Session III		by Mr. Gokul Raut
	13:30 - 14:00	Take out the substrate and cool it	Mushroom Farm
	14:00 - 14:30	Nutritional and medicinal value of mushroom	Classroom
	14:30 - 15:00	Spawning and make the packets – store them	Mushroom Farm
	* Group 1 - 20 Participants only. Snacks and tea were required		
<b>Day 3</b> <b>September 25,</b> <b>2004</b>	Session I		by Mr. Gokul Raut
	10:00 - 11:30	Chopping the straw and soak in water	Mushroom Farm
	11:30 - 12:30	Clean the straw and drain off water	Mushroom Farm
	Session II		by Mr. Gokul Raut
	12:30 - 13:30	Pasteurization of straw	Mushroom Farm
	13:30 - 14:00	Tea break	Classroom
	14:00 - 15:00	Spawning and making the packets	Mushroom Farm
	* Group 1 - 20 Participants only. Snacks and tea were required		
<b>Day 4</b> <b>September 26,</b> <b>2004</b>	Session I		by Mr. Gokul Raut
	10:00 - 10:30	Chopping the straw and soak in water	Mushroom Farm
	10:30 - 11:00	Theory on pasteurization of straws	Classroom
	Session II		by Mr. Gokul Raut
	11:00 - 11:30	Clean the straw and drain off water	Mushroom Farm
	11:30 - 12:00	Pest & disease management – theory only	Classroom
	12:00 - 12:30	Start pasteurization of straws	Mushroom Farm
	12:30 - 13:30	Pasteurization continues and tea break	

<b>September 27, 2004</b>      Day 5	Session I		by Mr. Gokul Raut
	10:00 – 11:30	Chopping the straw and soak in water	Mushroom Farm
	11:30 – 12:30	Clean the straw and drain off water	Mushroom Farm
	Session II		by Mr. Gokul Raut
	12:30 – 13:30	Pasteurization of straw	Mushroom Farm
	13:30 – 14:00	Tea break	Classroom
	14:00 – 15:00	Spawning and making the packets	Mushroom Farm
* Group 2 – 20 Participants only. Snacks and Tea required.			

**Table 3.** Training schedule for circus returnees (Mushroom Cultivation Training Part II)

<b>October 4, 2004</b>     Day 1	Session I		by Mr. Gokul Raut
	10:00 – 10:30	Opening of plastic bags & watering on packets	Mushroom Farm
	10:30 – 11:00	Post-harvest management & drying methods	Mushroom Farm
	11:00 – 11:30	Packing, marketing and cooking	Mushroom Farm
	11:30 – 12:30	Practical work on opening the plastic bags	Mushroom Farm
	12:30 – 13:00	Tea break	Classroom
* Snacks and tea were required			
<b>October 5</b>  Day 2	10:00 – 15:00	Preparation of straw packets	Mushroom Farm

**Equipment & costs**



**Figure 4.** Growing house under construction



**Figure 5.** Floor work for growing house



**Figure 6.** Two plastic tunnels



**Figure 7.** Preparation for bag filling

Thatched houses were built to grow mushrooms in (40 × 15 × 8ft). The thatched house was made from wheat straw, bamboo and wooden supports. Plastic tunnels were constructed of plastic sheets with bamboo supports. The plastic tunnel can also be covered with straw. Two tunnels were built by eight of the girls' fathers as they wanted to contribute in some way to a project that would benefit their families and communities on a long term basis.

Equipment includes straw chopper, plastic bucket for soaking, sieve for draining (a wooden framed net), steamers (clay pots or metallic drum), kerosene stove, plastic bags, grain spawn and sprayer for watering. The cost for a 3-month mushroom training course for 50 people is as shown in Table 4.

The price of mushrooms fluctuates but a fixed price all year round, approximately NPR<sup>1</sup>100, will be given to the cooperative by the business manager for their mushrooms so that they will have a steady income. Initially the farmers will need more help financially but as they grow more mushrooms and their farms become well established the fixed price can come down.

Once all costs had been ascertained EBT wrote a project proposal to MushWorld requesting funding. MushWorld agreed to this proposal and provided funding for the project in stages.

**Table 4.** Costs for a 3-month mushroom training course for 50 people

	Item	Quantity	Cost in GBP <sup>2</sup>
Core costs	Lease of land for training centre	2 months	8.00
	Construction of a mushroom growing house and storage of equipment	2	160.00
	Tuition fee for 3 months	50	1190.00
	Total for core costs		1,358.00 (USD2,613.05)
Equipment	Chopper	2	8.00
	Plastic bucket	4	5.00
	Framed net	2	8.80
	Metallic drum	2	16.00
	Kerosene stove	2	9.60
	Sprayer	2	48.00
	Punching machine	2	0.80
	Total for equipment		96.20 (USD185.11)
Raw Material	Paddy straw	1,000kg	24.00
	Plastic bags	8Kg	7.60
	Spawn	250 bottles	60.00
	Chemicals		8.00
	Plastic sheet	20 metres	8.00
	Fuel for steaming		12.80
	Notebooks	50	7.50
	Booklets	50	4.00
	Miscellaneous		5.00
	Total for raw materials		136.90 (USD263.42)
Grand total			1,591.10 (USD3,061.38)

<sup>1</sup> NPR (Nepalese Rupee, USD1 = NPR78.045 in March, 2005)

<sup>2</sup> GBP (Great Britain Pound, USD1 = GBP0.5197 in March, 2005)

### Long term benefits

At the end of the courses, it was decided that all the participants would become members of the Nawajagaran Cooperative, which would entitle them to the equipment and a loan necessary to start producing mushrooms in their homes and villages, as well as the technical support that they might need in the future. It would provide an incentive for commitment to the project and farms. The cost of the establishment of the farms would be kept low by adapting equipment that many households already have for new use in mushroom farming. For example metal drums are used to make local alcohol but can also be used for the pasteurization of the substrate.

The girls have found much support from each other and have recognised the emotional benefits from working as a group. For those who prefer to farm as a group the association will maintain a farm at the training center. For those participants who live in very small houses, that are rented and without room for farming, they will farm from those members' houses which have room, or from the training center. The farm at the training center will be maintained even if there are not courses running at that time.

The cooperative will grow and harvest mushrooms at the farms before bringing the produce to the training center where we plan to offer processing facilities (drying and oil extraction) and where the business manager deals with the sale of the mushrooms. The money from the sales is divided between those who have produced mushrooms as well as paying back the loan for setting up the farm in the first place. The mushroom training center will become part of a farming center and will train girls in the production of a range of market garden produce.

### The Pilot Course

#### The course

After discussions with the circus returnees it was established that 40 returnees were interested in mushroom cultivation and in order not to oversubscribe the course the group was split into two groups of 20. In this way two courses could run concurrently and this will happen in future so that a greater number of people can benefit from the training in a shorter time.

The pilot course ran part time over one month and covered the growth of oyster mushrooms. The course began in the classroom with the theory (Fig. 9) before moving onto the practical side where the participants were actively involved—learning through participation (Figs. 10). Mushrooms were grown and sold on the course and this will happen on future courses.

The staff at NCWF have been involved with the project from the beginning and having seen the success of the course and learnt the skills involved, and they have set up their own mushroom growing house at the Head Office in Bhairahawa and have produced a very healthy harvest.



Figure 8. Trainees of the pilot mushroom training course



Figure 9. Mixed participants consisting of parents, circus returnees and others in theory lesson

#### Comments from the course

The pilot mushroom training course started on 23<sup>rd</sup> September 2004 and the first stage of the course finished on 11<sup>th</sup> October when all participants were presented with a certificate. The course was a huge success and the reports throughout the course were very positive:

- From Dr. Manandhar after the first week - "The programme went very well. I am very happy with the girls. I am sure they will do well in mushroom cultivation."
- From Dr. Manandhar after the second week: "My assistant, Gokul Raut has come back from Hetauda. He has completed the practical work and the girls have prepared about 180 balls which are accommodated in the shed. We have to wait for three week to allow them to mature."
- From Captain Khem Thapa, Director of NCWF - "The first part of the training went well. According to the trainer, the crops looks really good and we should have pretty good harvest in two weeks time."
- From Philip Holmes, Director of EBT - "All is going well with the mushroom cultivation initiative having just seen its first harvest - and a bumper one it was too. The girls were given the first mushrooms for themselves but a second consignment was sold to a local hotel."



**Figure 10.** Hand-on class activities **A:** Chopping straw **B:** Soaking and cleaning of straw and draining off water **C:** Pasteurization of straw **D:** Bag filling **E:** Spawning **F:** Spawned substrate bag **G:** Hole making **H:** Spawn run **I:** Fruiting bodies

## Conclusions and Recommendations

### Conclusions

The pilot mushroom farming training course was monitored and evaluated throughout in order to understand the requirements for future courses. The conclusions from the successful completion of 40 circus returnees on the pilot course are discussed below.

The mushrooms have so far been sold to the local market but the potential of the nationwide market and exporting is understood. Lack of refrigeration and difficulty in transport due to the political situation in Nepal make supply to other areas of the country difficult. Therefore in the future some mushrooms will be dried using simple technology, and this will



**Figure 11.** The Esther Benjamins Trust and the Nepal Child Welfare Foundation working for the welfare of Nepalese children

open up the nationwide market and also the very valuable export market.

The costs for the pilot course were kept low, EBT and NCWF recognise the need to keep technology simple and ensure cost effectiveness to guarantee the sustainability of the project. It is felt, however, that some expansion is necessary in order to increase the economic success in the future and a processing center will be constructed.

Because the pilot course in mushroom farming was a success with good harvests, profitable sales and the circus returnees enthusiastic EBT and NCWF are looking at other produce that can be grown using the same approaches and techniques.

## Recommendations

Roger Cozens (Greenacres Consultancy), an agricultural specialist, visited the project in November 2004 and offered his professional advice on the project. His recommendations were:

- To consider mushroom processing such as drying and canning which increases profitability of mushroom production by enabling mushrooms to be sold nationwide and overseas.
- To grow oyster and shiitake mushrooms as they are simpler to grow and do not need such sophisticated building work. But to also develop new varieties using sawdust substrate from the local sawmills.
- In order to increase production there is a need for a pasteurisation area, a spawn preparation and spawning room and a cropping room.
- To use the straw that is used as a substrate as a fertilizer for vegetables or chicken feed after mushroom production is complete.
- To trade the product 'ethically' since the one of the fastest growing sectors within the food market is high value products from organic and sustainably managed land.

Roger Cozens was most impressed by the standard of cultivation that he saw, especially in terms of control against contamination.

In conclusion, with the completion and evaluation of the pilot course and with the inclusion of the recommendations from Roger Cozens the mushroom farming training course will be replicated with adjustments so that circus returnees can successfully grow mushrooms and other produce on a long term scale benefiting themselves, their families and the local community. It is felt that mushroom farming and processing is a way of impacting upon many lives through sustainable means and by reducing the poverty in the Makwanpur district of Nepal it will also reduce the need for families to send their children away under illegal contracts to work in the circuses; helping to achieve EBT's aim to see the end of the use of child performers in circuses.

**Table 5.** Investigation phase categories and strategies

<b>Participatory</b>	<ul style="list-style-type: none"> <li>• Use participatory methods in the analysis phase to seek the views of a range of stakeholders, including poor people, to ensure relevant information.</li> <li>• Negotiate on equal terms a process and principles for intervention with project partners.</li> <li>• Involve a range of stakeholders in implementation to strengthen ownership and thus improve sustainability.</li> </ul>
<b>People-centered</b>	<ul style="list-style-type: none"> <li>• Ensure that the needs and priorities of the poor are central and primary.</li> <li>• Take concerns of disadvantaged groups into account, e.g. women, minorities and children.</li> <li>• Involve stakeholders from different organisations, government, NGOs and communities, to ensure that poor people's livelihood perspectives are represented.</li> </ul>
<b>Partnerships</b>	<ul style="list-style-type: none"> <li>• Negotiate fundamental principles and values for working with partners in order to ensure a transparent and solid foundation for ongoing relationships.</li> <li>• Plan for capacity building and handing over responsibility for implementation to partners for long-term sustainability.</li> </ul>
<b>Holistic</b>	<ul style="list-style-type: none"> <li>• Look beyond single sector projects / programmes.</li> <li>• Involve agency staff and partners from different disciplines to broaden the range of perspectives.</li> <li>• Make linkages between different project / programme plans.</li> </ul>
<b>Dynamic</b>	<ul style="list-style-type: none"> <li>• Be aware that livelihoods change over time (seasonal and longer term).</li> <li>• Adopt a process approach, with effective feedback and monitoring procedures.</li> <li>• Accept that the project environment is likely to change over time. Establish a process for reviewing and re-negotiating project objectives and processes at stages during the life span of the intervention.</li> </ul>
<b>Building on strengths</b>	<ul style="list-style-type: none"> <li>• Do not analyze and plan around problems only, but also focus on strengths.</li> <li>• Use strengths, including good relationships, as a starting point for planning and build on them.</li> </ul>
<b>Macro-micro links</b>	<ul style="list-style-type: none"> <li>• Recognise the impact of policy and institutional context on livelihoods.</li> <li>• Make links between micro reality and macro level influences.</li> <li>• Involve stakeholder from a range of levels: from national to local, giving equal voice to all.</li> </ul>
<b>Sustainable</b>	<ul style="list-style-type: none"> <li>• Ensure activities are sustainable in long term (including economic, resource and social sustainability).</li> <li>• Keep exit strategies in mind, and ensure transfer of skills and responsibilities.</li> </ul>

## REFERENCES

- Cozens, Roger. 2004. *Report for the Esther Benjamins Trust and the Nepal Child Welfare Foundation*. 4pp.

## Part II Mushroom for Better Life

## Chapter 10

Regional Studies**MUSHROOM GROWING IN LAO PDR**

Tawat Tapingkae

Rural Science and Technology Development Center, Thailand (tawat123@yahoo.com)

**Introduction****Environment**

The Lao People's Democratic Republic was proclaimed and officially declared a Marxist-Leninist government in December 1975. A new economic reforms policy designed to create a market-oriented economy was launched by the Laotian Government in 1986. Since that time the Lao PDR has opened itself widely to the world.

Lao PDR is landlocked, with an area of 236,800km<sup>2</sup>, 6,000km<sup>2</sup> of which are bodies of water and 230,800km<sup>2</sup> land. The country sits at 18° N longitude, 105° E latitude, in southeastern Asia, and is surrounded by Vietnam, Thailand, Cambodia, China and Myanmar. Lao PDR stretches 1,700km from north to south and is between 100-400km wide from east to west. The climate is typical tropical monsoon weather, with a cool season having temperatures down to 16°C that lasts from October to February. The short warm has temperatures up to 40°C from March until April, and the rainy monsoon season runs from May through September.

In Lao PDR, rice cultivation occupies 627,000ha and produces 1.72 million tons per year. Maize cultivation occupies 28,000ha and produces 56,000 tons per year. Cassava and sweet potato cultivation occupies 15,000ha and produces 160,000 tons per year. Vegetable cultivation occupies 16,500ha and produces 156,000 tons per year. Laotian farmers also cultivate soybean, mung bean, groundnut, sugarcane, white sesame, kapok, cotton, sawdust, cattle, water buffalo, horse, chicken, and duck (DDFI, 2003).

**Brief history of mushroom cultivation**

Rice is the main crop of the people who live in this monsoon climate. From June to October the main fields are under water, and only rice crops can grow under these conditions. Other crops are grown after the rice harvest. Straw mushroom is a crop which can earn growers enough money to survive with throughout the year. The large quantities of rice straw left after the harvest can be used as substrates for the cultivation of straw mushrooms. The cultivation process is very simple and productive.

The knowledge of how to grow straw mushrooms is limited to those farmers who have earlier participated in the training that was provided by the government officials through supporting international agencies such as UNDC, FAO, and JICA. In 1996, the Lao PDR government sent a group of government officials and farmers to get training in mushroom growing at Kanlasin in Thailand. After that session, the trainees came back to Lao PDR and constructed a mushroom training center with support from The Soil and Crop Extension Center, the National Agriculture and Forestry Extension Service, and the



Figure 1. Map of Lao PDR

Ministry of Agriculture and Forestry. Mr. Kenkham Bouphaniveth, one of the trainees who had been trained in Kanlasin came to work as a mushroom production engineer. The facilities for mushroom growing were set up as a trial mushroom farm and demonstration area. More than 500 extension service officials and farmers have attended training in this center as of Dec. 2004. Ajarn Bouavone Duangdeuane is another alumnus of the training in Kanlasin. He now teaches mushroom cultivation at Luang Prabang Agriculture and Forestry College and many mushroom growers in Luang Prabang are his students. Ajarn ComeSingh, another graduate of the Kanlasin mushroom training program is a mushroom specialist who has trained many students at the Faculty of Agriculture, in the National University of Lao PDR. Many graduates of this program have become the mushroom extension service officials and growers. Mr. Kammune, another Kanlasin training attendee, works at the Seed Multiplication Center, Department of Agriculture, Ministry of Agriculture and Forestry in Na Phok as a mushroom specialist. He built the pilot project for mushroom cultivation that lasted for two years and acquired enough knowledge and experience to run the demonstration farm and he is going to organize future mushroom training courses for officials and farmers.

Straw mushroom cultivation in Lao PDR is limited to the few months after the rice harvest. Some other straw mushroom growers use banana leaves obtained from the banana plantations. Despite the fact that straw mushrooms can be more profitable than any other crop, growing of straw mushroom can be complicated and hard work for the average farmer; and this crop seems to suit only the certain few who would be good at any job.

## Mushroom Species

Through observations and interviews with mushroom sellers it has been determined that most of the mushrooms that are sold in the markets are species imported from Thailand. Most of the mushroom species grown in Lao PDR are brought directly from TMCC (the Thailand Mushroom Culture Collection. Tel: +662-5790147, +662-5614673, Fax: +662-9406371) or indirectly through mushroom accessories suppliers. In 1996, TMCC had in its collections 16 species and 750 strains of cultures. They now distribute 15 species and 40 different strains to growers. In the collection there are 18 strains of straw mushroom (*Volvariella volvacea*), 60 strains of white mushroom (*Agaricus bisporus*), 79 strains of brown mushroom (*Agaricus bitorquis*), 332 strains of shiitake (*Lentinus edodes*), 190 strains of oyster mushroom (*Pleurotus* spp.), 16 strains of wood ear mushroom (*Auricularia* spp.), 18 strains of linchu (*Ganoderma lucida*), 4 strains of Hed KhonKaaw, 5 strains of Hed KraDaang, 5 strains of Hed TheenRad (*Tricholoma crassum*), 8 strains of enokitake (*Flammulina velutipes*), 4 strains of yanangitake (*Agrocybe*



**Figure 2.** Mushroom species **A:** Hed Cone (*Termitomyces* sp.) **B:** Hed NangFah-Bhutan (*Pleurotus pulmonarius*) **C:** Hed NangLom (*Pleurotus ostreatus*) **D:** Hed Khamint (*Cantharellus cibarius*) **E:** Hed Fuang (*Volvariella volvacea*) **F:** Hed Boad (*Lentinus* sp.)

*cylindracea*), 1 strain of purple oyster mushroom (*Pleurotus salmonicolor*), 1 strain of monkey head mushroom (*Hericium erinaceus*), 2 strains of porcini mushroom (*Boletus* spp.), 2 strains of Hed Kraeng (*Schizophyllum commune*), 1 strain of shimejitake (*Hypsizygus marmoreus*), 1 strain of Hed Tuo (*Coprinus comatus*), 1 strain of white jelly mushroom (*Tremella fuciformis*), 1 strain of Hed HooKwang (*Lentinus strigosus*), and 1 strain of Hed TheenPlog. TMCC annually provides 6,500-8,500 bottles of mushroom cultures to 250 growers and 20 agencies. A quantity of this goes to the Lao PDR through mushroom spawn providers.

**Table 1.** Cultivated mushrooms in Lao PDR

Scientific name	Local name(common name)	Scientific name	Local name(common name)
<i>Volvariella volvacea</i> (Bull. Ex Fr.) Sing.	Hed Fuang, Hed Faang, Hed Boa (straw mushroom)	<i>Lentinus polychrous</i> Lev.	Hed Lome, Hed KraDaang, Hed Boad
<i>Auricularia auricular</i> (Hook.) Underw. <i>Auricularia polytricha</i> (Montagne) Saccardo	Hed HooNooh (wood ear mushroom)	<i>Lentinus squarrosulus</i> Mont.	Hed KohnKaaw
<i>Pleurotus ostreatus</i> (Jacquin ex Fries) Kummer	Hed NangRom (oyster mushroom)	<i>Lentinus sajor-caju</i> (Fr.) Fr.	Hed TheenPlog
<i>Pleurotus pulmonarius</i> (Fies) Quelet	Hed NangFaa, Hed NangFaa Bhuthan (angel mushroom, Indian oyster mushroom)	<i>Lentinus giganteus</i> Berk.	Hed Thongfone
<i>Pleurotus abalonus</i> Han. <i>Pleurotus cystidiosus</i> O. K. Miller	Hed PhoaHuu (abalone mushroom)	<i>Coprinus cinereus</i> (Schaeff. Ex. Fr.) S. F. Gray	Hed TuaNoa (ink cap mushroom)
<i>Lentinus edodes</i> (Ber.) Sing.	Hed Hom (shiitake)		

**Table 2.** Native (wild) species seasonally available in the local markets

Scientific name	Local name(common name)	Scientific name	Local name(common name)
<i>Astraeus hygrometricus</i> (pers.) Morg.	Hed Thop, Hed Phor, Hed Hiangk, Hed Payom (earth star)	<i>Russula cyanoxantha</i>	Hed NaahMoi
<i>Termitomyces fuliginosus</i> Heim	Hed Pluag, Hed Cone (termite mushroom)	<i>Russula rosacea</i> Pers. Ese Gray	Hed Deang, Hed Hed GulahbDeang, Hed ThaKleiDeang
<i>Amanita caesarea</i> (Fe.) Schw.	Hed KhaiHaanLuang, Hed RangokLuang	<i>Dictyophora duplicata</i> (Basc. ex. Fr.) Fisch.	Hed Phai, Hed RaangHae (dancing mushroom)
<i>Amanita princeps</i> Corner & Bas	Hed KhaiHannKaaw, Hed RangokKaaw	<i>Phaeogyroporus proleptosus</i> (Berk. et. Broome) Mc Nabb	Hed Haa
<i>Russula delica</i> Fr.	Hed Klei, Hed Thaclei, Hed Lohm (grass-white russula)	<i>Cantharellus cibarius</i> Fr.	Hed KhamintLuang, Hed ManPhoo
<i>Russula aeruginea</i> Lindbl.	Hed KleiLhaangKiew, Hed thacleiLhangKiew, Hed LohmLhangkiew (grass-green russula)	<i>Lactarius volemus</i> (Fr.) Fr.	Hed Faan

## Cultivation

### Open field cultivation of straw mushroom

Open field growing is simple and cost effective. During December, the farmers will harvest and thrash rice in the fields. Rice straw bundles are then moved and soaked overnight in small mud-ponds (Figs. 3). The next morning, the wet straw is carried from the pond to the growing site by a small cart hooked to a motorcycle (Figs. 4).

The farmers then put 15-20cm of wet straw in a frame that measures 35-40cm at base, 25-30cm at the top, 35-40cm in height, and 100-150cm in length (Figs. 5). The farmers make a spawn mixture with one part spawn and 10-20 parts supplement (Fig. 6A). Sawdust, mung bean or soybean-husks, rice bran, kapok pits, manure, compost, organic fertilizer, cotton waste, soybean meal, and malt residue can be used as supplements. They place 5-7cm of this spawn mixture parallel to the margin of the substrate pile, making 2-4 layers, depending on the weather, and making more layers in cool months (Figs. 6B and C). The growers make 40-44 or more piles, placing each 15-20cm apart from the others (Figs. 7). The piles are then covered with

thin plastic sheet and shaded with straw pads on bamboo frames for 5-7 days (Figs. 8A and B). The growers then take off the plastic sheet, water as needed, and then put together the bamboo frame cover with a plastic sheet and straw pad. In 3-5 days the first flush of mushrooms can be harvested. The crop will continue for 3-4 more flushes. The production from one pile of substrate will be 1-3kg, depending on the quality of the spawn, the supplements, weather and maintenance.



**Figure 3.** Straw soaking **A:** Straw carrying **B:** Loading down straw to the pond **C:** Soaking straw for one night



**Figure 4.** Moving the wet straw to growing site **A:** Loading wet straw on the cart hooked to a motor-cycle **B:** Unhooking motorcycle **C:** Unloading wet straw from cart



**Figure 5.** Making bed **A:** Steel bar & galvanized sheet frame **B:** Laying the frame **C:** Putting in straw



**Figure 6.** Inoculation **A:** Spawn & supplements (dried cattle manure and rice bran) mixing **B:** Putting the first layer of mushroom spawn into two rows **C:** Putting in the last straw layer



**Figure 7.** Completing the bed **A:** Pressing to compact **B:** Taking out the frame **C:** One plot (40-44 blocks) takes a half day to prepare.



**Figure 8.** Plot and pinning **A:** Plastic-sheet covering **B:** Shading by straw with bamboo-frame **C:** Fruitbody initiation

**Table 3.** Cost of each item

Item	LAK <sup>1</sup> / kg	LAK/bed	LAK/44 beds (USD)
Straw	750 / bag	$750 \times 4=3,000$	132,000 (16.8)
Spawn	5,500	$5,500 \times 0.75=4,125$	181,500 (23.1)
Rice-bran	1,500	$1,500 \times 7.5=11,250$	495,000 (63.1)
Ox-dung	250	$250 \times 7.5=1,875$	82,500 (10.5)
Kapok-pit	1,125	$1,125 \times 7.5=8,437.5$	371,250 (47.3)
Cotton-waste	2,250	$2,250 \times 7.5=16,875$	742,500 (94.7)
Cassava-root bark	250	$250 \times 7.5=1,875$	82,500 (10.5)
Sawdust	100	$100 \times 7.5=750$	33,000 (4.2)
Plastic sheet	40,000	$40,000 / 44=909.1$	40,000 (5.1)
Bamboo		1,000	44,000 (5.6)

### Bag cultivation of other mushrooms

Northern and north-eastern Thailand and the Lao PDR have native mushrooms that are mainly wood rotting mushrooms (Table 4), and can be found on many kinds of trees such as Mai-Teng (Rung, Hiang, Thakian, *Hopea odorata* Roxb.) and Krabahg.

**Table 4.** Native wood rotting mushrooms

Scientific name	Local name	Scientific name	Local name
<i>Pleurotus ostreatus</i>	Hed NangRome	<i>Pleurotus pulmonarius</i>	Hed NangFaa
<i>Auricularia auricula</i>	Hed HooNooh	<i>Ganoderma lucidum</i>	Hed LihnJuu
<i>Phellinus linteus</i>	Hed TheenChaank	<i>Macrocybe crassa</i>	Hed Jaan
<i>Lentinus polychrous</i> Lev.	Hed Lome or Hed Boad	<i>Lentinus squarrosulus</i> Mont.	Hed KhonKaaw
<i>Lentinus sajor-caju</i> (Fr.) Fr.	Hed TheenPlog	<i>Lentinus giganteus</i> Berk.	Hed ThonkFone

<sup>1</sup> LAK (Lao Kip, USD1 = LAK7,843 in February, 2005)

## 1) Substrate preparation

a) Sawdust in Luang Prabang is available in large quantities from many sawmills, and it is free for anyone who needs it.

In Vientiane, sawdust is available from a truck loader who offers sawdust at LAK200,000 per truck, which is an amount that can fill 2,000-3,000 of the 7 × 12 inch plastic bags. The cost for this sawdust will be LAK75-100 per bag.

b) There is straw left in the rice field after harvesting.

c) Rice bran and broken rice are available from small rice mills or animal feed shops at about LAK100 per kg and LAK200 per kg respectively.

d) Sugar is available from any grocery at LAK4,000-5,000 per kg.

e) Lime is available from hardware shops at LAK6,000 per 8kg bag.

f) Magnesium sulfate and gypsum are available from mushroom suppliers at LAK6,000 per kg.

g) Other accessories such as plastic necks (THB<sup>2</sup> 250 per bag; each bag has 700-900 pieces) are available from the supplier.

## 2) Fill substrate into a 7 × 13 inch plastic bag; Compact to 2/3; Put on neck; Put on cotton plug; Wrap paper on cotton plug

**Formula 1:** 100kg sawdust (para rubber, tamarind), 3-5kg rice bran, 0.5-1kg lime or calcium carbonate or gypsum, 2-3kg sugar, 50-55% water content

**Formula 2:** 100kg mixed sawdust, 1kg ammonium sulfate, 1kg lime; mix with water and leave to ferment for 2-3 months, then mix with the following; 3kg rice bran, 2kg sugar, make 50-55% water content (Arahmpong-pan and Pimkarn, 2001)

**Formula 3:** 100kg sawdust, 3-5kg rice bran, 3kg sugar, 0.2kg magnesium sulfate, 1kg calcium carbonate, and 60-65% water content

**Formula 4:** 100kg sawdust, 5kg rice bran, and 70% water content (Petcharat, V., 1995)

**Formula 5:** 100kg sawdust, 5kg rice bran, 5kg broken rice, 2kg sugar, 1kg lime, 0.5kg magnesium sulfate and 55-65% water content (Chanthacoat *et al.*, 2003)



Figure 9. Weighing a substrate bag

Table 5. Various formulae from survey

Survey No.	Sawdust (kg)	Rice straw (kg)	Rice bran (kg)	Broken rice (kg)	Sugar (kg)	Lime (kg)	Gyp. (kg)	Mag. (kg)	Vit. B <sub>1</sub> (g)	Water Cont. (%)
1	100	-	5	5	2	1	-	0.5	-	55-65
2	170	70	15	5-7	-	2	-	0.4-0.6	-	50-60
3	100	-	5	3	2	1	-	0.2	-	55-65
4	100	-	7	5	2	1	-	0.5	-	55-65
5	100	-	5	3	2	0.5	0.5	0.2	1	55-65
6	100	-	5	5	2	1	-	0.2	-	55-65
7	100	-	5	5	2	1	-	5	-	55-65
8	100	-	5	5	2	0.5	0.5	0.2	-	55-65
9	100	-	5	3	2	0.5	0.5	0.2	-	55-65
10	100	-	5	5	2	1	-	0.5	-	55-65
11	100	-	5	5	2	1	-	0.5	-	55-65
12	100	-	3-5	-	2-3	1	-	0.2	1	60-70
13	100	-	6	3	-	-	0.2	0.2	1	60-70
14	100	-	7	3	2	0.5	0.5	0.2	1	60-70
15	100	-	3-5	-	2-3	1	-	0.2	1	60-70

3) Load 100 substrate bags into a 200 l oil drum; Cover the 100 substrate bags above the oil-drum with a garbage plastic bag; Boil until the steam builds up; Use a needle to punch small holes in the garbage bag to let excess steam escape from the drum; wait for 3-4 hours. Stop boiling and allow the drum to cool down to room temperature (Figs. 10).

4) Inside the inoculating room; Inoculating with grain spawn (1 bottle for 20-30 bags) (Fig. 11).

<sup>2</sup> THB (Thai Baht, USD1 = THB38.30 in February, 2005)

5) Carry the bags into the incubation room; Incubate them at 28-32°C for 30-35 days (Fig. 12). The white mycelium will grow and cover all parts of the substrate surface and start to initiate fruitbodies. For Hed Boad the mycelium will turn to orange or iron-rust color and then to dark-brown till black when it is ready to initiate fruiting. This fruiting will take place 80-90 days after inoculation.



Figure 10. Drums for pasteurization A: Drums on fireplace B: Rack inside the drum



Figure 11. Spawning A: Spawn bottles B: Spawning



Figure 12. Incubation



Figure 13. Hed Boad fruitbody

- 6) Bring the incubated bags into the growing house; Take out the cotton plugs from substrate-bags to make room for the fruitbodies to come out. Wait a few more days before starting the mushroom harvesting. It takes 3-5 days after the first detected mushroom primordia. In case of Hed Jant and Hed Thongfone, cut off the plastic bags then put together 5-10 pieces in one big plastic bag and put 3-5cm casing soil on the upper surface. This final packaging will cause the mycelia to produce a better quality of mushrooms
- 7) The harvesting can be continued for 3-5 days and the farmer can start the new fruiting cycle again in 2-3 weeks. All together the harvesting can continue for 6-8 flushes over the course of 4-6 months. Each ten bags can produce 1.5-3.0kg.

**Table 6.** Material costs

Item	Price (LAK/kg)	Quantity (g/100kg)	Cost (LAK/1kg bag)
Sawdust	75-100	100,000	75-100
Rice bran	750-1,250	5,000	37.5-62.5
Broken rice	1,500-2,000	5,000	75-100
Sugar	3,750-5,000	2,000	75-100
Lime	750	1,000	75
Gypsum	2,500-6,000	500-1,000	
Magnesium sulfate	3,200-6,000	200	6.4-12
Pumice	3,125		
Calcium carbonate	6,000		
Organic fertilizer	2,500		
Plastic-neck	70-90/bag	100	70-90
Plastic-bag	60/bag	100	60
Bagging	60/bag	100	60
Spawn	1,200-2,000/bottle	4-5 bottles	48-100
Ready to open	1,200		
Wage	20,000/day		800-1,200*
Growing house	1,500,000/house**		8.3***

\* Wages for 1 worker, 4-6 months employment from inoculation to crop ending

\*\* 1 standard growing-house (4 × 8 × 3.5m) contains 3,000 bags/6 months/6 crops

\*\*\* 3 years usage

## Spawn

Spawn is considered the seeds or seedlings of mushroom plants. Spawn is made by culturing mushroom spores or tissues on agar media for a few days until the white-threaded mycelium emerges from the spores or tissue. This mycelium will be then multiplied on cooked cereal grains for 10-15 days. The mycelium growing on the cereal grains can then be used as mushroom spawn.

Good quality spawn can lead to success in mushroom cultivation. The criteria for quality mushroom spawn include:

- 1) The starting culture should be a good strain, obtained from a government agency or university that has screened for the best from among many different sources and/or developed the strain via hybridization and/or mutagenesis. Because there is not a government agency that works on this matter in the Lao PDR, most of the starting cultures are brought from Thailand. The cultures cost THB70/bottle in Thailand and are then sold in the Lao PDR for THB100/bottle. If this starting culture is subcultured more than two or three times, the spawn degenerates and this results in lower yield and abnormal fruitbodies.
- 2) The starting culture and resulting spawn should be free from pests and diseases. A good spawn provider will inspect their products before selling them to their clients. These inspections for mites and molds can be done with a magnifying glass.



Figure 14. Sorghum grain spawn from Thailand



Figure 15. Imported sorghum grain spawn

The procedure used in spawn production is as follows:

- 1) Imported starting culture: The starting culture from Thailand will be on PDA (Potato Dextrose Agar) slant in small whisky bottle, which can be transferred to 50-60 subcultures on PDA in small whisky bottles (Fig. 16). Each can be used to inoculate rice grains in medium size whisky bottles and will be sold as spawn to the growers at LAK1,200-1,500 (USD0.15-0.19) per bottle. One bottle of spawn can be used to inoculate 20-30 growing bags.
- 2) PDA preparation: Peel out the skin of 200-300g potato and cut it into small pieces; boil them in 1,000 $ml$  water for 15 minutes; filter out the pieces and take the filtrate liquid; put in 15-20g agar and stir till the agar dissolves in the liquid; put in 20-40g dextrose (D-glucose, sugar) and stir to dissolve. Use funnel to fill 20-30 $ml$  PDA solution in flat Maekhong whiskey bottle; put in cotton plug; wrap up the plug with paper sheet by rubber band; sterilize the PDA bottles in autoclave at 15 psi, 121  $^{\circ}C$  for 20-30 minutes; take out from autoclave to make slant and cool down.
- 3) Tissue culture: Mushroom tissue culture will be made by sterilizing cutter or isolating needle in sterilizing solution (10% clorox or 70% alcohol or 3% hydrogen peroxide) for some minutes, cut a small piece of the clean part of mushroom fruitbody (unexposed to the air part), place on slant agar media inside PDA bottle (heat the bottle mouth part by alcohol flame everytime before and after opening the bottle), the operation is made in airtight cabinet (Fig. 17) (this can be made from a corrugated paper box or polystyrene foam sheet or wood), leave these bottles until the mycelium from mushroom tissue grows covering the surface of agar media.



Figure 16. Starting agar culture



Figure 17. Transferring hood from polystyrene foam



Figure 18. Home made autoclave



Figure 19. One spawn provider shows starting agar culture and behinds are the oil-drums used for substrate pasteurization.



Figure 20. Kapok pit grass



Figure 21. 200g kapok pit is used as substrate



Figure 22. 3 days after inoculation



Figure 23. 10 days after inoculation

- 4) Rice-grain substrate: Boil the rice grain till the core of the grains are exposed, drain out the water, dry for 2-3 hours in the sun, pour the grains into MaeKhong whiskey bottles, put in cotton plugs, wrap the plugs with a paper sheet, sterilize the bottles at 15 psi, 121 °C for 20-30 minutes, take out and cool down to room temperature. Use isolating needle to cut small pieces of agar (the parts covered with mushroom mycelium) from the starting culture, transfer to the grain bottles (flame heat the mouth of the bottles before and after plugging cotton and operate inside airtight hood), leave until the mushroom mycelium covers the grain, at which point it is ready to use as mushroom spawn.

5) For straw mushrooms, kapok pits (Fig. 20) or cotton residue can be used as the substrate. Soak the kapok pits or cotton waste in water for 2-3 hours, drain out the water, pack the mix into plastic bags, sterilize and inoculate in the same way as in grain spawn culture.

Some spawn providers make spawn by soaking the kapok pits in water for 2-3 hours, draining off the excess water, mixing with sorghum grain spawn or cotton waste spawn from Thailand (1 spawn : 10-20 kapok pit), making a pile 30-45cm height, covering the pile with a plastic sheet, leaving the mix for 5-7 days, then putting it in a plastic bag, and selling it as straw mushroom spawn (Fig. 21).

### Mushroom Growing Houses



**Figure 24.** Imperata grass roof with two stacks of substrate bags as the walls



**Figure 25.** A house covered with a plastic sheet made from fertilizer bags in order to raise the temperature and humidity for Hed Boad



**Figure 26.** Corrugated paper from old boxes is used for the walls and ceiling. These carton box materials are already over 3 years



**Figure 27.** A standard (4 x 6m) government instructed growing house



**Figure 28.** A 4 x 6m standard growing house at the Mushroom Experiment and Extension Service Center



**Figure 29.** Airtight growing house. It can be fumigated to control pests and diseases.



**Figure 30.** This growing house has its whole sides covered with Imperata grass to prevent flies.



**Figure 31.** Roof structure



**Figure 32.** Rack frame structure

## Pests and Diseases

Sciarid fly (*Lycoriella* spp.), Phorid fly (*Megaselia* spp.), springtails (*Leidocyrtus* spp. and *Achorutes* spp.), mites (*Luciaphorus* sp.), green mold (*Gliocladium* sp., *Trichoderma* spp., *Penicillium* sp. and *Paecilomyces* sp.), black mold (*Aspergillus* spp. and *Botryodiplodia* sp.), orange mold (*Neurospora* sp.), slime mold, brown rot (*Pseudomonas tolaasii*), and brown spot and yellow rot (*Pseudomonas fluorescens*) are common and often found in plastic bag mushroom cultivation operations.



Figure 33. Minute flies on oyster mushroom



Figure 34. Mite damaged bag

The principal reasons for pest problems are:

- 1) The growing house is near to the sources of pests and diseases.
- 2) The old substrate bags and the new ones are in the same room.
- 3) Diseases and pests in any infected bags are not eliminated from the growing room.
- 4) The used substrate bags and the infected ones are not treated properly. They are merely thrown out and left at the front door or a few yards from the growing house (Fig. 35).
- 5) The growing rooms and incubation rooms share the same space. In this way mites from the old bags can find new food sources (Fig. 36).
- 6) The growing rooms and incubation rooms are not airtight. Fumigation could not be performed. The houses are too easily accessed by flies entering the growing rooms with mites carried on their bodies.



Figure 35. Damaged bags sit alongside the good ones



Figure 36. New bags sit next to the old ones

Keeping out flies is very helpful. In one case in Luang Prabang, a farmer using corrugated paper board from old boxes as a ceiling and wall material for his growing house. Screen nets at the doors and opening parts keep flies out of the house, and this precaution results in his mushroom houses being clean and free from mites and green mold.

An airtight room could be created easily by using plastic film, or old sheets of newspaper coated with flint coat, or the

paper from old portland cement bags. Fumigation could then be performed simply way by using sulfur powder in a hot pan. In many cases, mites were detected in mushroom spawn. In this case, a 100% infection rate with green mold will follow. A magnifying glass is very helpful to detect mites. Phosphine fumigation should be performed by mushroom spawn providers before providing spawn to their clients. Many cases of mites result from having visitors who have recently visited another mushroom farm. Any workers who have performed mushroom harvesting in the morning should not come to work in the inoculating and incubating area before washing themselves and changing into fresh clothing.

Some mushroom spawn providers have started introducing *Bacillus subtilis* from Thailand for green mold control, and their results are promising. The *Bacillus subtilis* producer advises that, the application for *Bacillus subtilis* should proceed as follows:

Use coconut fruit, open the top and put 1g of *Bacillus subtilis* powder into the coconut. Close the opened part and leave the coconut over night. The next day the mixture in the coconut is ready to be mixed with 20l of water, and this mixture can be used for spraying green mold infected areas. This mixture will reduce current infections and prevent future infections of green mold. A similar procedure is also used to prepare strains of *Bacillus thuringiensis* that could control minute fly larvae in the growing substrates. The results of this are still limited. In the future a preparation useful against *Steinema* nematode will be experimented with by the Thai spawn supplier.

Many kinds of herbs are used in controlling pests and diseases. Garlic, cinnamon bark, eucalyptus leaf, neem seed, citrus peel and lemon grass are extracted by alcohol (whiskey) or vinegar and applied along with chitosan. Yellow glue strips are also used to trap and monitor flies and mites.

## Marketing

**Table 7.** Cost of production (LAK/kg)

Mushroom	Substrate	Plastic bag, neck	Spawn	Labor	Depreciation
Oyster	300-500	100	10	100	100
Angel	300-500	100	10	100	100
Wood ear	300-500	100	10	100	100
<i>Lentinus</i>	300-500	100	10	100	100
Straw	100-200	50	20	50	30

**Table 8.** Buying and selling price (LAK/kg)

		Oyster M.	Angel M.	Wood ear M.	<i>Lentinus</i> M.	Straw M.
Luang	Wholesale price	2,000	7,000-9,000	6,000-9,000	12,000-15,000	-
Prabang*	Retail price	2,200-2,500	12,000-15,000	12,000-15,000	15,000-20,000	-
Vientiane**	Wholesale price	7,000	6,000-9,000	7,500	12,000	12,000
	Retail price	9,000	9,000-15,000	10,000	15,000	15,000

\* Luang Prabang: Posy Market, Mitthaparb Market

\*\* Vientiane: Luang Market, Khuawdin Market



**Figure 37.** Posy market, Luang Prabang **A:** Vegetable retailer displays wood ear mushrooms among others **B:** An oyster mushroom grower sells her mushrooms on the ground



**Figure 38.** At the Mitthapab market in Luang Prabang, wood ear mushrooms are sitting among chili, galangka, curmint, and peppermint.



**Figure 39.** Thongkankhum market, Vientiane **A:** 10kg at LAK9,000 per kg, but 1 kg is LAK12,000 **B:** High quality oyster mushroom (*Pleurotus ostreatus*) at LAK9,000 per kg **C:** At another corner sellers can get LAK15,000 per kg



**Figure 40.** Khuawdin market, Vientiane **A:** Local high quality straw mushroom at LAK15,000 per kg **B:** These two growers sell their angel mushrooms **C:** High quality oyster mushrooms



**Figure 41.** Kad Luang **A:** One bag is filled with 0.5kg oyster mushroom, wholesale is LAK8,000 and retail is LAK9,000 **B:** Hed TuaNoa are the second most popular mushrooms after straw mushrooms. **C:** Hed KohnKaaw the favorite mushrooms from the jungle are now imported from Thailand

## Potential for Mushroom Development

Straw mushrooms is considered an important ingredient in Tomsaep (spicy soup), which is an important item in the Laotian people's diet. The demand for these mushrooms is high at all times of year. Straw mushrooms can be found around rice straw piles and banana plantation piles in limited quantities during the rainy season. During this period most mushrooms in the market are cultivated mushrooms. Some few of these cultivated straw mushrooms are cultivated openly in the rice fields, but many tons of straw mushrooms are imported from Thailand every day.

One particular straw mushroom spawn provider supplies know-how and growing materials to the Lao PDR's straw mushroom growers. There is also a booklet on "The Method of Straw Mushroom and Oyster Mushroom Cultivation" in the Lao PDR that was published by the Lao PDR government. The publishing department of the Government also provides growers with educational materials. There are facilities and persons that have considerable knowledge and experience in mushroom cultivation at the Faculty of Agriculture of the National University of Lao PDR Luang Prabang Agricultural College. The seed multiplication Center, Nah Phok, the Department of Agriculture (DOA), the Ministry of Agriculture and Forestry (MOAF), the Soil and Crop Extension Center, the National Agriculture and Forestry Extension Service, the Ministry of Agriculture and Forestry could all develop very helpful programs to help the people learn and practice mushroom cultivation.

There are many waste-products from agriculture and industry which can be used as straw mushroom substrates. These include rice straw and stumps, banana stems and leaves, soybean and mungbean stems, leaves and seed husks, kapok husks and pits, cassava leaves, stems, roots, and bark, sweet potato stems and leaves, water hyacinth, corn stems and leaves, sugarcane bagasse, malt residue from beer factories, sawdust, coffee seed husks, and corrugated paper boxes. The Lao PDR raises 588,000 head of cattle, 73,000 goats, 1.5 million pigs, 42,000 horses, 1 million buffaloes, and 8 million chickens (Figures from Library of Congress Country Studies, 1994). The large quantity of manure produced by these animals would be good mushroom substrates or supplements.

The Lao PDR annually grows 521,788ha of rice, which produces 1,409,296 tons of grain (FAO/WFP-Special Report, 1995) and about 10 million tons of straw. If 10 kg straw can produce 1kg of mushrooms, then 1 million tons of mushrooms could theoretically be produced each year from the nation's excess rice straw. One hectare of rice cultivation can provide 6 tons of rice straw and stumps at one crop cycle, and these can be used to produce 600kg of straw mushrooms that are worth LAK4,800,000-6,000,000 (USD612-765). A similar amount of labor would earn only LAK1,000,000-1,500,000 (USD127.5-191.25) during 16-20 weeks of rice cultivation.

The spent sawdust substrate from other mushroom cultivation can be used as substrate for growing straw mushroom. This spent straw is even better than new straw, but this spent substrate is usually burned now. The spent straw substrate from straw mushroom cultivation is in turn very good for oyster mushroom cultivation, but no farmers in the Lao PDR currently use spent straw substrate from straw mushroom for this purpose.

Climate conditions in the Luang Prabang area are suited for cool climate mushrooms and there is a huge quantity of sawdust available in this area. This situation could be ideal for the cultivation of white-mushrooms (Hed Champignon, French mushrooms, *Agaricus bisporus*), shiitake (Hed Hom, *Lentinus edodes*), enokitake (silver and golden needle mushrooms, *Flammulina cylindrica*), eryngii (giant oyster mushrooms, *Pleurotus eryngii*), monkey's head mushrooms (Hed HuaLing, *Hericium* spp.), and yanagitake (Hed Conyeepuun, *Agrocybe cylindrica*). The southern part of the country grows coffee for exporting and the large quantity of coffee residue could be very good substrate for oyster mushroom cultivation. Wood and bamboo can be obtained at very low prices. *Imperata* and *dipteroctopus* leaves can be used to build semi-permanent mushroom growing houses very inexpensively. Good design of growing house could prevent pests and diseases. Excess electricity from the government's hydroelectric dam could provide clean and cheap electric power for ventilation and microclimate control for mushroom growing houses.

The Lao PDR consumes 15,000 tons mushrooms per year, a rate of 2.5kg per year per capita. This total is partly from wild mushrooms but mainly from mushrooms that are imported fresh from Thailand and dried from China. Only 2% of the available rice straw is used in mushroom production and 80% of the Lao PDR consumption of mushrooms is imported from Thailand, Vietnam and China.

The more than 650,000 tourists recorded since 2001 (Department of Domestic and Foreign Investment (DDFI)) will increase to more than 1 million. These visitors could be additional potential mushroom consuming customers for the big restaurants and hotels. Observations made in Luang Prabang showed that a pork roasting-pan restaurant called "JengishKhan roasting-pan" is very popular among the foreign visitors, and this single restaurant uses more than 50 kg of

mushrooms daily. There is potential for using mushrooms in the fast-food shops and European restaurant industries that are growing in the Lao PDR.

## REFERENCES

- Anong, J. 2001. *Mushrooms of Thailand and Cultivation Techniques*. 8<sup>th</sup> ed. Bangkok, Thailand: Thai Wattanaphanit Publishing House. pp. 177-188.
- Arahmpongpan, P. 2001. Hed Lome and Hed Khonkhaow cultivation. In: Hiranyapradit, Sooppanit and Surawood, Apinya, eds: *Technical Paper Economical Mushrooms Cultivation*. Bangkok, Thailand: The Plant Pathology and Microbiology Office. pp.19-21.
- Bandoni, R.J., A.A. Bandoni, and T.W. Flegel. 1998. *The Forgotten Kingdom*. Bangkok, Thailand: Genetic Engineering and Biotechnology Center (BioTech), National Science and Technology Development Agency (NSTDA). 136 pp.
- Chanthacoat, et al. 2003. *Straw Mushroom and Oyster Mushroom Cultivation Procedure*. 2<sup>nd</sup> ed. Vientiane, Lao PDR: Lao PDR Publishing House. 16 pp.
- Chiangkool, A. 1996. Hed Khonkhaow (*Lentinus aquarrosulus* Mont.). In: Phanutath, Chanyooth and TaengChub, Nongnoot, eds: *Mushroom Production Techniques*. Bangkok, Thailand: Vegetable Group, Horticultural Extension Services Office, Department of Agricultural Extension Services. pp.14-23.
- DDFI, Lao PDR. 2003. available at [http://www.invest.laopdr.org/business\\_guide.htm](http://www.invest.laopdr.org/business_guide.htm)
- Deephrom, C. 1999. *Mushroom Culture in Thailand*. Bangkok, Thailand: Deephrom Chaiwongkiat Publishing. pp. 188-192.
- Kasem, S. 1994. *Mushrooms and Macro Fungi in Thailand*. Ubolrajathani, Thailand: Sritharm Offset Printing House. pp. 222-30.
- Mushroom Researchers and Growers Society of Thailand (MRGST). 2000. *Poisonous Mushrooms*. Bangkok, Thailand: MRGST. pp. 63-68.
- Pannee, V. and S. Panarath. 2004. Thailand mushroom culture collection. *Kasigone* 77(3): 88-96.
- Pegler, D.N. 1983. *The Genus Lentinus: A World Monograph*. London, U.K.: Kew Bull. Add. Ser. X. HMSO. p.168-170
- Petcharat, V. 1995. Cultivation of wild mushroom: I. Hed Khon Khao (*Lentinus aquarrosulus* Mont.), Songklanakarin J. Sci. Technol. 1995, 17(1): 43-56.
- Porameess, R., and T.W. Flegel. 2001. *Thai Mushrooms and Other Fungi*. Bangkok, Thailand: Genetic Engineering and Biotechnology Center (BioTech), National Science and Technology Development Agency (NSTDA). pp. 268-272.
- Praphaisree, P. and C. Suwalaks. 1996. Thailand mushroom culture collection. In: *Seminar Paper on Mushroom Sight, National Para-rubber Research and Agricultural Research Exhibition*. June 5-7, 1996, Kasetsart University, Bangkok. pp. 41-52.
- RajaBunditSathan. 1996. *Edible Mushrooms and Poisonous Mushroom*. Bangkok, Thailand: RajaBunditSathan Publishing House. pp. 170-179.
- Thailand Mushroom Culture Collection (TMCC). 2001. *Available Mushroom Culture List* (leaflet). Bangkok, Thailand: Applied Microbiology Work Group, Plant Pathology and Microbiology Office, Department of Agriculture. 2 pp.

## Part II Mushroom for Better Life

## Chapter 10

Regional Studies**MUSHROOMS AND CULTIVATION OF  
MUSHROOMS IN VIETNAM**

Phan Huy Duc

University of Natural Sciences, VNU, Hanoi, Vietnam (p-huyduc@hn.vnn.vn)

**Natural Environment**

Vietnam lies in the center of the south east Asia, and experiences an annual rainfall of 1,200-2,000mm, a relative humidity of 80-100%, and an average temperature of 22-27 °C. Due to these favorable conditions, plants are green year round, there are always fresh flowers, ripe fruits available, and the rice fields produce two or three crops of rice every year.

Within the relative uniformity of the weather and climate, each locality in the country has its own characteristics. In the South, the dry season and the rainy season are prolonged. The northern areas experience a warm and a cold season. During the cold winter, sometimes it snows in some mountainous regions. In summer the temperatures sometimes rise to 39-40 °C. This climatic diversity is why farmers in Vietnam can cultivate many different species of mushrooms, ranging from the species of tropical regions like straw mushroom<sup>1</sup> to the mushrooms of the temperate zone such as button mushroom<sup>2</sup> and shiitake<sup>3</sup>. This mushroom abundance is one reason why Vietnam is recognized around the world as one of the nations with highest biodiversity. Indeed, flora and fauna are abundant in Vietnam, including a rich mycoflora containing many species of edible mushrooms, toxic mushrooms, and medicinal mushrooms, and other mushrooms as yet not recognized.



Figure 1. Map of Vietnam

**Mushroom Production****Outline**

The ethnic minorities of Vietnam have known for more than a thousand years how to cultivate some species of mushrooms such as shiitake, even if the culture was only occasional and mostly by chance. To start the process these people would crush shiitake and mix into a dilute rice soup, and then use a feather to brush this solution on the bark of felled tree species such as *Elaeocarpus* sp.<sup>4</sup>, *Quercus* sp.<sup>5</sup>, and *pasania*<sup>6</sup>. After a period of time the mushrooms would appear and the people gather them. This method is wasteful because for even a large tree, the amount of mushrooms collected would not be large.

In the 1960's the cultivation of mushrooms according to standard farm methods began in Vietnam, and straw mushrooms

<sup>1</sup> *Volvariella volvacea*, Vietnam name (Vnn): Nam rom, nam ra

<sup>2</sup> *Agaricus bisporus*, Vnn: Nam mo

<sup>3</sup> *Lentinula edodes*, Vnn: Nam huong, Nam dong co

<sup>4</sup> Vnn: Cay com

<sup>5</sup> Vnn: De do

<sup>6</sup> Vnn: De soi

were cultivated in beds and in the field, and shiitake was grown using the hole method. Due to many causes, the industry experienced many ups and downs, and in general the movement was still essentially undeveloped. In the 1990's the culture of mushrooms gradually become stabilized and the industry was created, along with standards of production.

If it was necessary to cultivate mushrooms with machines and modern equipment, Vietnam could not develop a mushroom cultivation industry. A considerable financial investment and large scale operation are not appropriate for the small family farms in Vietnam, so mushroom cultivation advocates have developed a "small tent" production model, based upon hand-crafted construction, and this model is a good fit with the realities of the Vietnamese farmers.

The combined annual crop of all cultivated mushrooms in Vietnam is valued at USD40 million. The production capacity of Vietnam is rising, mainly as the scale of the many home farm operations enlarges. Now average family farms have a capacity to handle 1-6 tons of raw substrate material per crop. Most farms use handcrafted equipment that often lowers the productivity levels. Those operations that have the capacity to process 10-15 tons of raw substrate per crop are in the minority, and make up only 3.5% of the growers.

Cooperatives operate in some villages, and tend to produce good crops, and the "farm mushroom" and "village mushroom" models are being promoted.

### The benefits

The principle financial advantage of mushroom growing is that the turnaround time is short, and the recovery of invested capital is rapid. Mushroom cultivation is not difficult, and is possible in every part of the country. The cultivation of mushrooms has brought benefits to many rice farmers, as a result of which these farmers have enjoyed years of sufficient farm production. There is a general feeling in Vietnam that mushroom cultivation has made peoples' lives better. Mushroom cultivation is thought to be 3 or 4 times more efficient as a farm activity than raising pigs or chickens, 2 or 3 times more efficient than planting mulberry and cultivating silkworms, and 4-5 times more efficient than working in a rice field.

The cost for one ton of straw and supplements for the cultivation of oyster mushroom are about USD55. This can produce 600kg of mushrooms, and the price per kg of oyster mushrooms is USD0.28.

Balance:  $\text{USD}0.28 \times 600\text{kg} = \text{USD}171$ ,  $\text{USD}171 - \text{USD}55 = \text{USD}116$

Thus 1 ton of straw in 30m<sup>2</sup> can produce USD116 in three months. A farmer would need to cultivate 3,500m<sup>2</sup> of rice for six months to earn a similar amount.

It can be calculated that for a day's labor, a farmer can realize USD1 for growing rice, USD1.5 for cultivating straw mushrooms, USD1.9 for cultivating button mushrooms, and USD2.2 for cultivating oyster mushrooms. Mushroom cultivation can also be done in a farmer's spare time, and family members and especially children can easily assist. Also, there is a lower initial investment than growing rice.

In the Mekong Delta some rice farmers have increased their income through selling the rice straw to mushroom growers. Other farmers are using the straw themselves to grow mushrooms, and these farmers can now produce rice and mushrooms, with the rice generating 70% of the income, and mushrooms producing the other 30% of the total farm revenue.

In the province of Vinh Phuc in northern Vietnam an average rice farmer will generate USD1,400-1,500 in income every year and have 4-5 months of unoccupied leisure time. Many farmers have learned recently that they can also cultivate mushrooms, and thereby generate incomes USD2,300-2,400 per year. This increase in income has allowed many farmers to improve their living conditions, repair their houses, and buy televisions and motorcycles.

In the district Long My province of Can Tho in the Delta of the Mekong in the past year, the cultivation of straw mushroom contributed to reduce the house of hunger and poverty from 22% to 13%. The houses surmounting the poverty reach to 40%. About the scale of cultivating mushroom, in Vietnam according to each area there are the models convenient to the cultivation of different mushrooms.

In the north of the country, most mushroom farming is done on small family farms. In the south, in addition to the small family farms, there are some much larger mushroom growing operations, ranging in size from those that generate USD1,000 per month to those that have an income of over USD10,000 per month.

In some places these larger operations take the form of a village cooperative having between ten and one hundred houses producing together. There are a very few well financed commercial mushroom businesses with capital ranging up to USD320,000. Success and failure of both the small and the larger mushroom business depend on technical expertise, management efficiency, and fluctuations of the mushroom buying markets.

One unique aspect of the mushroom cultivation systems in Vietnam is the common cyclical use of the substrates. In this system straw mushrooms are cultivated on fresh straw substrate, oyster mushrooms are next grown on the residual substrate, then worms (for poultry feed) are raised on the remaining organic material, and finally the last stage materials are

used as fertilizer for garden plants cultivation.

### Cultivated mushroom species in Vietnam

Today Vietnamese farmers are producing six kinds of mushrooms: straw mushroom, button mushroom, oyster mushroom, wood ear mushroom, *Ganoderma* mushroom, and monkey head mushroom. With variations according to regional climate, farmers can cultivate these kinds of mushrooms year round in many regions. In the southern provinces, farmers cultivate mainly straw mushroom, wood ear mushroom, and *Ganoderma* mushroom, whereas in the provinces of the north farmers cultivate button mushroom, oyster mushroom, shiitake, straw mushroom, wood ear mushroom and *Ganoderma* mushroom. There are many different strains, some better than others, because there are no dominant outstanding strains.

Following are descriptions of some the various mushrooms that are currently cultivated in Vietnam, both for use in the country and for exportation abroad.

#### Straw mushroom



Figure 2. Straw mushroom beds

This is the mushroom with the highest cultivation productivity in both North and South Vietnam, despite the fact that the seasons vary widely between the two regions. In the north mushroom production is possible only in summer, but in the south, such as the region around the Mekong delta, the weather is hot all year around. This climate also produces abundant straw, the raw material for growing this mushroom. This southern area produces most of the national crop of straw mushrooms.

In past years, the total annual crop was 50,000-60,000 tons but recently the production has diminished because of less exportation. This mushroom has probably the shortest cycle of all plant crops, as the whole period from sowing to harvest is very short. In optimal conditions the first harvest can begin within 11 days after inoculation.

The raw material for the culture of the straw mushroom is chiefly straw and stubble. Some growers use other materials such as discarded cotton, and sugarcane dregs, from which a farmer can produce 25kg of mushroom from 100kg of raw material: The provinces of the south produce 90% of the national crop of straw mushroom. Farmers take full advantage of any sawdust produced, and with this they cultivate mostly wood ear mushroom, but also some straw mushroom.

#### Button mushroom



Figure 3. Washing button mushrooms harvested in the cave

In the south there is only one location, the holiday city of Da Lat, located at 1,500m altitude in the province of Lam Dong, where the average annual temperature 21 °C is favorable for the culture of button mushrooms. Because the raw substrate materials must be transported from the plains up into the mountain, the culture of the button mushroom here has not developed. In the north the cold winter and plentiful availability of raw straw and stubble material make the area a very favorable location for the culture of button mushrooms. The national button mushroom crop is about 1,000 tons per year, all from this region. Local residents consume about 20% of the crop, and the rest is exported to France, Italy, and Taiwan, often as salted button mushrooms packed in plastic 20 liter jars.

On the average, from one ton of raw dry straw and stubble, with a cultivation period from October 15 to April 15, a farmer can harvest 200-300kg

of fresh mushrooms. In addition, the spent compost is abundant and a good garden fertilizer.

#### Oyster mushroom<sup>7</sup>

Oyster mushrooms are cultivated both in the north and the south of the country. In the 1990's the mushroom was cultivated in the region surrounding Ha Noi and in most of the provinces of the Red River Delta.

The annual crop weighs 7,000-8,000 tons and is increasing every year. In addition to the species *Pleurotus ostreatus*, some others are also cultivated such as *Pleurotus sajor-caju*, *P. florida*, *P. pulmonarius*, and *P. eryngii*. The possible substrates on which to cultivate oyster mushrooms in Vietnam are widely varied, including straw and stubble, cast-off cotton, sugarcane

<sup>7</sup> *Pleurotus ostreatus*, Vnn: Nam so, Nam bao ngu

dregs (*Saccharum officinarum*), *Cana edulis*<sup>8</sup> dregs, and coffee seed husks. Oyster mushrooms are often produced average 70kg of mushrooms per 100kg of raw material. In some provinces of the South, such as Ben Tre, coconut husk fiber from the plantations has been used to cultivate both straw mushrooms and oyster mushrooms.

#### Wood ear mushroom<sup>9</sup>

In Vietnam, wood ear mushrooms are sometimes cultivated by boring a hole into substrate trees such as *Artocarpus heterophyllus*<sup>10</sup>, *Ficus racemosa*<sup>11</sup>, or *Sesbania grandifolia*<sup>12</sup>. This method will not work with tree species that have notable essential oils. The old method of boring holes is little utilized today because of the large area required, the high probability of infection by other fungi, and the long time period required.

Today the majority of farmers cultivate wood ear mushrooms in sawdust contained in nylon bags. Farmers can cultivate on miscellaneous sawdust or on sawdust of a specific tree like *Ficus religiosa*<sup>13</sup>. The sawdust of the tree *Hevea brasiliensis*<sup>14</sup> gives the highest productivity. While the average productivity of the culture on miscellaneous sawdust reaches 60-70g/block, the sawdust of the rubber tree yields 100g/block, with each block containing 1.2-1.4kg of substrate.



Figure 4. Oyster mushroom drying

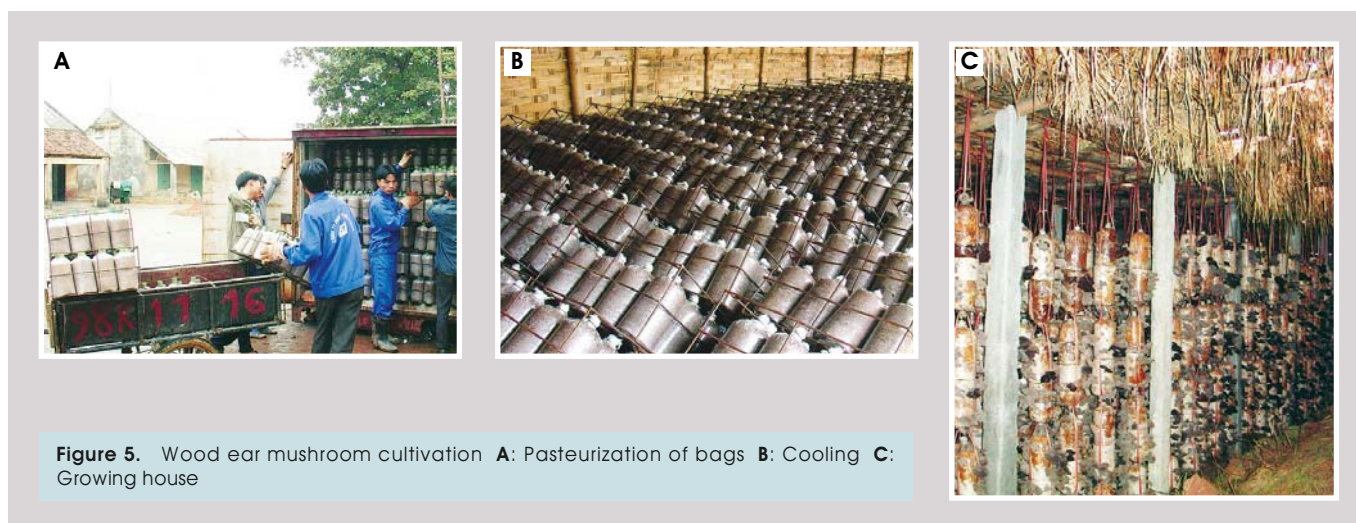


Figure 5. Wood ear mushroom cultivation A: Pasteurization of bags B: Cooling C: Growing house

Wood ear mushrooms develop all around the year but do best in the summer season in the North and in the rainy season in the South. The annual national wood ear mushroom crop weighs 1,500-2,000 dry tons/year, and represents about 10% of the world totals. Formerly exported only to some countries in Asia, this mushroom is now exported to both in Europe and America. Besides the sawdust substrate in Vietnam wood ear mushroom is also cultivated on sugarcane dregs, cast off cotton, and manihot<sup>15</sup> stems.

#### Ganoderma mushroom<sup>16</sup>

This mushroom is cultivated both in the north and in the south of Vietnam, most often on a substrate of sawdust. Sawdust from rubber tree gives the highest productivity.

Other substrates such as cast off cotton and sugarcane dregs are also used, but the sugarcane dregs must be treated to avoid infection from other fungi. Vietnam produces enough sugar to create 3 million tons of sugarcane dregs every year. This waste leads to the pollution of the environment around the sugar factories and cane fields. The sugarcane dregs are used for mushroom culture by adding some nutritive substance like rice bran, maize flour, urea nitrogen, super phosphate, or lime powder ( $\text{CaCO}_3$ ). From one ton of sugarcane dregs, a farmer can produce 35-40kg of dry *Ganoderma* mushrooms. The results of biochemical analysis of the mushrooms cultivated on the sawdust and the mushrooms cultivated on sugarcane dregs are similar, especially the amino-acid contents. The production of *Ganoderma* mushroom in the year 2003 was about 100 tons.

*Ganoderma* mushrooms are converted into teas, capsules, refreshment beverages, and tonic wines that are consumed

<sup>8</sup> Vnn: Dong rieng

<sup>9</sup> *Auricularia polytricha*, Vnn: Nam tai meo, Moc nhi

<sup>10</sup> Vnn: Cay mit

<sup>11</sup> Vnn: Cay sung

<sup>12</sup> Vnn: Cay so dua

<sup>13</sup> Vnn: Cay bo de

<sup>14</sup> Vnn: Cay cao su

<sup>15</sup> *Manihot esculenta* (Vnn: Cay san)

<sup>16</sup> *Ganoderma lucidum*, Vnn: Nam linh chi

locally and exported to various other countries in Asia, Europe, and North America. Many *Ganoderma* mushrooms are sold in Korea and China, where the consumers prefer the Korean *Ganoderma* mushrooms even though their price is higher.



**Figure 6.** *Ganoderma* mushroom cultivation **A:** Mixing sawdust **B:** Spawn run **C:** Fruiting

### Monkey head mushroom<sup>17</sup>

This species of mushroom grows normally at temperatures of 16-20 °C. In Vietnam there was much research done in an effort to cultivate this mushroom in the tropical conditions of 25-33 °C. This research resulted in the large scale cultivation of this mushroom in Vietnam. Monkey head mushroom is both eaten and used as a medicine to treat illnesses. One particular fortifying tea manufactured from monkey head mushrooms by a private company has been awarded a gold medal at the national fair. One kg of monkey head mushroom in Ho Chi Minh City is priced at VND<sup>18</sup>300,000 (USD19). The price of a similar kg in Japan and Hong Kong is USD100.

### Others

In addition to the species of cultivated mushrooms mentioned above, some private and governmental agencies have cultivated several other species of mushrooms, but these mushrooms are not productive in Vietnam: *Trametes versicolor*<sup>19</sup>, winter mushroom<sup>20</sup>, shiitake, *Pholiota nameko*<sup>21</sup>, and *Tremella fuciformis*<sup>22</sup>.

Many production firms from America, Japan, Italia, Germany, and Taiwan make visits to Vietnam to investigate the possibility of producing mushrooms there. In the future there may be the required cooperation and investment to initiate this activity. Today, Vietnam still imports some edible and medicinal mushrooms from China, such as the Tuckahoe mushroom<sup>23</sup> 100 tons, silver ear fungus 200 tons, and shiitake 500 tons.

## Mushroom Consumption

Mushrooms have been eaten by Vietnamese peoples for many centuries. The most commonly eaten mushroom has been the wood ear mushroom, and all regions of Vietnam are familiar with this type. However, wood ear mushrooms are not used in great quantity because they are mainly used in meat pies and other dishes as a flavoring agent. The stuffing for ethnic dishes such as steamed rolls, meat pies, and fried meat rolls all contain wood ear mushroom as a flavoring. Foreign visitors are also fond of the flavor of wood ear mushrooms.

Shiitake was traditionally considered a luxury food, appropriate for consumption on the national Tet holiday or during wedding ceremonies, but today shiitake are much more widely consumed, and are commonly imported from China. Straw mushrooms are more commonly consumed in the south, and prices fluctuate, rising on the first and fifteenth of each month, as well as on holidays.

In the past eating mushrooms has been more common among the more sophisticated citizens, and it is for this reason that most mushrooms were traditionally consumed in the towns. The consumption of mushrooms among the rural citizens is rising rapidly. Although canned mushrooms from China are common in both rural and city areas, the market for wood ear mushroom and shiitake seems to be ready for expansion. The consumption of fresh mushrooms is increasing everywhere, aided by a general awareness that mushrooms are a clean vegetable with high nutritional value.

<sup>17</sup> *Hericium erinaceus*, Vnn: Nam hau thu

<sup>18</sup> VND (Vietnam Dong, USD1 = VND15.789 in March, 2005)

<sup>19</sup> *Coriolus versicolor*, Vnn: Nam van chi

<sup>20</sup> *Flammulina velutipes*, Vnn: Nam kim cham

<sup>21</sup> Vnn: Nam chan chau

<sup>22</sup> Silver ear mushroom, Vnn: Ngan nhi

<sup>23</sup> *Poria cocos*, Vnn: Nam phuc linh

In addition to fresh mushrooms, many mushrooms are consumed dried, salted or canned. About 20% of the annual consumption is dried mushrooms, mainly shiitake and wood ear mushrooms. Salted mushrooms are prepared by first boiling and rinsing, then packing in a 20 liter plastic jar, adding fresh layers of salt over every layer of mushrooms. Salted mushrooms are aged for 12 months before using. Salted mushrooms, mostly straw mushrooms and button mushrooms make up another 20% of the annual crop. Canned mushrooms make up about 10% of the crop. Salted and dried mushrooms are usually done by family farms, while the canning is done in factories in the south. Other mushroom containing products include deep fried mushrooms, noodles with mushrooms, mushroom powder (flour) and mushroom salads. In 2003, an initiative to register a processing system approved by the American FDA (Food and Drug Administration) started with the intention to assist Vietnamese mushrooms growers in preparing products for export to the USA.

The export markets for straw mushrooms include Italy, Germany, France, Japan, Australia, but 70% of the salted canning mushrooms exported from Vietnam go to Malaysia, Taiwan, and Thailand. Since 2002, Vietnamese canning factories have been exporting canned mushrooms to America. This new business increased the trade profits of the canning factories in the South by 50%. The southern provinces export salted straw mushrooms and canned mushrooms by the thousands of tons per year to markets in Taiwan, Hong Kong, and Thailand. The northern provinces export salted button mushrooms and canned button mushrooms to Japan, Taiwan, Germany, and Russia. The production cost of salted mushrooms is USD800 per ton, and the selling price is USD1,200 per ton.

## ■ Mushroom Development Projects

Mushroom cultivation projects in Vietnam have been carried on by both government agencies and international organizations. In 1985 the FAO assisted the Hanoi mushroom research into productive local strain development, and in 1986 the FAO assisted similar work in Ho Chi Minh City. In 2000, the FAO assisted the province of Thai Binh in managing a program to teach farmers about producing edible mushrooms.

In 1991 through 1993 the Vietnamese Ministry of Science - Industry and Environment managed a project to teach local farmers the mushroom growing systems used in Taiwan. In 1992 and 1993, a mushroom company imported the canning factory equipment needed to process mushrooms according to the Italian industrial system. The provinces and cities such as Hanoi, Quang Ninh, Ha Nam, Ninh Binh, Nam Dinh, Thai Binh, and Ha Tay have all invested significant amounts in research and farmer education concerning edible mushroom production. Although the future capacity for this industry is great, current activity is still low.

In recent years, the state has launched a variety of projects such as "Research on the industry of culture of some edible and medicinal mushrooms and the means of prevention illness with cultivated mushrooms," "Project to select and produce the strains required for the culture of edible and medicinal mushrooms, for both local consumption and export abroad," and "Research to select the kinds of edible mushrooms and precious medicinal mushrooms in Vietnam." These projects have contributed well to the general knowledge about the Vietnamese mushroom cultivation industry, but the industry growth has not been as robust as it might have been, due to the lack of any widely available quality mushroom strains. Most strains used are still imported from other countries, as there is not a local factory capable of producing the required spawn on a large scale. General confidence in the export market is also low, and in general, Vietnamese mushroom farmers are not as aggressive and productive as mushroom farmers in other countries around the world.

## ■ Mushroom Cultivator Requirements

The cultivation of mushrooms has recently become a viable profession that is capable of generating significant income. In order to succeed in this endeavor, beginning mushroom cultivators need to follow these guidelines:

- 1) Growers must cultivate the correct types of mushrooms according to their situation. For example, *Ganoderma* and wood ear mushrooms should be cultivated in areas where there is sawdust available. Oyster mushrooms and button mushrooms should be cultivated where there is plenty of rice straw.
- 2) Potential pest problems must be avoided in order to produce high volumes of mushrooms. Cultivation areas must be kept clean and full of fresh air. The mold and insects that occur in areas of poor hygiene will harm productivity. After every final harvest, the mushroom cultivation area should be cleaned thoroughly and disinfected with powdered lime or formalin.
- 3) Only one kind of mushroom should be cultivated in one room. The cultivation rooms should not be crowded and grow-

ers should not cultivate combinations such as straw mushrooms on the floor and blocks of wood ear mushroom hanging above.

4) Market conditions should be noted before cultivation begins to avoid over production.

These ideas are the important points which the new cultivator must consider, and much research should be done before any cultivation begins.

## Conclusion

Vietnam has a great potential for the development of the mushroom cultivation industry. The raw materials are plentiful, and the climate is favorable, including temperature ranges that allow the cultivation of a wide variety of species. The required labor is readily available in Vietnam, and the world market for mushrooms is expanding every year. Certainly in the future, the mushroom cultivation industry of Vietnam will develop in an impressive fashion.

To take advantage of the potential of this crop, farmers and assisting agencies should press forward and encourage a further development of this industry. Vietnam is blessed with abundant raw substrate materials and labor, and should increase the cultivation of mushrooms for consumption locally and export abroad.

## REFERENCES

- Bizhishu, Z.G., and L. Taihui. 1993. *The Macrofungus Flora of China's Quang Dong Province*. The Chinese University Press.
- Phan, H.D. 1991. Preliminary investigation of the Agaricales order in some region of the delta of the North Vietnam. *Journal of Biology* 13(1) 23-29.
- Phan, H.D. 1993. *Research and Culture of Mushrooms in Vietnam*. Report of the inter-country ad-hoc meeting on collaborative mushroom research and development. Organized by Food and Agriculture Organization (FAO) of the United Nations and Department of Biology, the Chinese University of Hongkong. August - 1993. p.43-46.
- Phan, H.D. 1994. *Boletus cf felleus*. *Forestry Review* 7. pp.18.
- Phan, H.D. 1994. Research and culture of mushroom *Lentinus edodes* in Vietnam. In: *Program and Abstracts International Symposium on Production and Products of Lentinus mushroom*. China. pp. 33-34.
- Phan, H.D. 1994. Research and culture of mushroom *Ganoderma lucidum* (Leyss: Fr) Karst. in Vietnam. In: *Program and Abstracts International Symposium on Ganoderma Research*. October. Beijing, China. pp.7-8.
- Phan, H.D. 1994. Some species of wild mushroom used as foodstuff in Vietnam. *Journal of Biology* 16(2): 1-5.
- Phan, H.D. 1995. Cultivation mushroom in Vietnam and its prospect (report). In: *Training of Resource Centre Managers in Asia and Asia LDC's in Commercial Mushroom Production and Business Managements*, October 1995, BIOTECH - UP Los Banos, Philippines.
- Phan, H.D. 1996. The mushroom species *Termitomyces eurhizus*. *Journal of Biology* 18(2): 11-12.
- Phan, H.D., and H.S. Jung. 1997. Fungal flora of Catba Island, Vietnam: ecosystem and biodiversity of Catba Park and Halong Bay, Vietnam. *Annal of Nature Conservation, KNCCN 12: Survey of the Natural Environment in Vietnam*. Seoul - Korea. pp.125-146.
- Phan, H.D. 1999. The species of *Agaricus* L.Fr emend. Karst in Vietnam and the utilization of their utility. *Conference and Abstract 3<sup>rd</sup> International conference on mushroom Biology and mushroom products*, Sydney. Australia. pp. 32.
- Phan, H.D. et al. 1996. *Red Data Book of Vietnam*. Hanoi, Vietnam: Science and Technics Publishing House. pp. 484.
- Singer R. 1986. *The Agaricales in Modern Taxonomy*. Federal Republic of Germany: Koeltz Scientific Book.

## Appendix 1. Edible Wild Mushrooms of Vietnam



Figure 1. Wild wood ear mushrooms in Vietnam

For hundreds of generations the Vietnamese people, especially those in the country and mountainous regions, have collected the many wild species of mushrooms growing around the houses, in the fields and in the forests, both as food and as medicine. First on the list is the wood ear mushroom (Fig. 1).

This is the most common wild species, and many people know how to gather it. Wood ear mushroom is found everywhere, from the plains to the mountain region, from the North to the South and from the countryside to the cities. Wood ear mushroom grows abundantly on many different substrates, even on the trunk of toxic plants belonging to the family of Apocynaceae such as *Nerium oleander* L.<sup>1</sup>, *Thevetia nerifolia* Juss.<sup>2</sup>. In addition to their value as foodstuffs, the Vietnamese people use wood ear mushroom to treat illness by employing traditional popular remedies.

The next mushroom on the list is the shiitake. The minority peoples in the province of the North, such as the Tay, Nung, Muong go into the forest to gather wild mushrooms that grow spontaneously during the cold winter days from November to April. The shiitake usually grows in the trunks of trees such as *Elaeocarpus* sp., *Quercus* sp., *Pasania* sp., and *Pithecolobium* sp.<sup>3</sup>. Every year during springtime in SA Pa, a tourism point in north Vietnam, many people go in the forest to gather the edible shiitake. Wild shiitake are smaller in size than the cultivated ones, but they have a stronger aroma. The mushroom *Lentinus tigrinus*<sup>4</sup>, usually grows on the trunks of different trees. In the rainy season, the people of the mountain region gather young edible *Lentinus* mushrooms. When these mushroom age, they become leathery, and this has given these mushrooms their popular name. The small *Termitomyces* mushroom<sup>5</sup> is named Tua rua, signifying the pleiad of seven stars, because the mushroom appears at the end of the spring and the beginning of the summer, at the same time as the pleiad of 7 stars appears in the sky. The mushrooms are small, but usually grow densely on lawns, and on termite nests, where people gather it to eat.

The mushroom *Termitomyces eurhizus*<sup>6</sup>, is so named because the mushroom grows usually on termite nests. The mushrooms appear in summer and sometimes continue until till November. The mushroom has a large fruitbody, and the diameter of the fruitbody sometimes reaches more than 20cm. This species of mushroom has been mentioned in poetry, such as the poem March in Tay Nguyen. It was also mentioned in the war against the aggressor in south Vietnam recently. One unit of the Army in the mountain region of Tay Nguyen lacked food and was hungry, but survived by finding and eating mushrooms. Some farmers have special tortoises that can assist in searching for this mushroom because this tortoise also usually looks for and consumes the *Termitomyces*. This mushroom grows in most provinces of Vietnam, on lawns, at the edge of the forests, on hills, in fields and particularly on termite nests in summer.

The straw mushroom grows in the country on heaps of straw or other stubble in a state of putrefaction. The mushrooms appear after summer rainfall and people gather the straw mushrooms to make soup. In the Red River Delta, they still plant the *Zizania latifolia*<sup>7</sup> as a food crop. In the stems of the plant there is a kind of parasite mushroom named *Yenia esculenta*. This species was formerly named *Ustilago esculenta*. When the plant is parasitized by the mushroom, the stems of the plant swell out, giving the phenomenon the name "the tuber of nieng." The tuber of nieng can be cut in small pieces to eat raw or stir-fry with egg or *Tylorynchus heterochaetus*<sup>8</sup>. The French in Vietnam years ago were very fond of eating the tuber of nieng boiled and dipped in butter.

Besides the mushroom mentioned above, in the Red River Delta the countryfolk still gather some species of wild mushrooms on the lawns, such as *Calvatia lilacina*<sup>9</sup>, *Agaricus campestris*<sup>10</sup>, and *Entoloma clypeatum*<sup>11</sup>. From the ancient capital Hue to the provinces in the South there exists the mushroom *Boletus cf. felleus*<sup>12</sup>. These mushrooms usually grow under the shade of the *Melaleuca leucadendron*<sup>13</sup> tree. From April to July, people gather many *Boletus*, and often carry them on their shoulders to the Dong Ba or An Cuu markets in Hue City for sale. When it is the season for mushrooms, most of the restaurants in Dong Ba market sell dishes with these Nam tram mushrooms. The Nam tram has a bitter taste like the fruit of *Momordica charantia*<sup>14</sup>. According to local tradition, the Nam tram mushroom has a fresh taste, is easy to digest, serves as a cleanser for the

<sup>1</sup> Vnn: Truc dao

<sup>2</sup> Vnn: Thong thien

<sup>3</sup> Vnn: Do ngon

<sup>4</sup> Vnn: Nam dai

<sup>5</sup> *Pordabrella microcarpa*, Vnn: Nam moi mu nho, Nam vuot

<sup>6</sup> Vnn: Nam moi

<sup>7</sup> Vnn: Cay nieng

<sup>8</sup> Vnn: con ruoi

<sup>9</sup> Vnn: Nam trung

<sup>10</sup> Vnn: Nam co day

<sup>11</sup> Vnn: Nam co tranh

<sup>12</sup> Vnn: Nam tram

<sup>13</sup> Vnn: Cay tram

<sup>14</sup> Vnn: Muop dang, Kho qua

liver, acts as a sleep aid and has the ability to expel worms. The Nam tram mushroom is boiled in soup with the leaves of the sweet potato *Ipomoea batatas*<sup>15</sup> or the leaves of the *Piper lalot*<sup>16</sup>. When making soup one can add shrimp<sup>17</sup>, and the flavor of the soup will be better and sweeter.

As the region of Hue, in the provinces in southeast Vietnam mushrooms appear after rainfall at the beginning of the season, and here many people rush to the forests to gather the mushrooms. Many poor children go to the forest to gather the tram mushrooms in order to sell them. Because they can thereby get money, the children call the mushroom “The present from the Gods.” The season of tram mushroom always provides hope for poor people, because they can eat the mushrooms fresh, or they can dry them, or they can sell them to the traders of Ho Chi Minh City who travel around buying mushrooms. In the province of Lang Son one of the species *Russula* sp.<sup>18</sup> grows under the leaf canopy of the tree *Engelhardtia chrysolepis*<sup>19</sup>. Due to the fruitbody of the mushroom having a red color like fire, the common name used by the local ethnic minority in the area is fire mushroom, Biooc pheo. In July, during the rainy season, the local people go into the forest and hunt Cheo trees in order to gather the mushroom. Many of these mushrooms are sold in the markets of Lang Son. In the vacation town Da Lat, at an altitude above 1,500m, the climate is fresh all year long. In the pine forest, *Boletus edulis*<sup>20</sup> mushroom grow. This species is gathered by the people and eaten fresh or cut in small pieces and then dried and sold to the popular restaurants in Ho Chi Minh City. During summer some of the minority people in the province of Lao Cai gather the mushrooms known as the split-gill or bird’s foot mushroom<sup>21</sup>. The collectors will cut down trees and leave the bark on, laying the logs near their homes or at the edge of the forest. When the mushrooms on the logs develop in thick clusters they gather them in their clothes-baskets and bring them to sell at the market (Figs. 2 and 3). Among vegetables in the market, the split-gill mushroom always is the product most quickly sold. According to Professor S. T. Chang, in 1993 the combined production of the mushrooms *Coriolus versicolor*, *Lentinula edodes*, and *Schizophyllum commune* produced sales of USD1.2 billion. Even in 1987, these 3 kinds of mushrooms brought to the branch of pharmaceutical produce of Japan USD769 million.

In the provinces of Quang Ninh and Hai Duong during the months of July and August, the people go into the pine forests to gather the *Cantharellus luteocomus* for both eating and selling at the market. The mushrooms usually grow in large groups on the carpets of rotten pine leaves (Fig. 4).

In the 1990’s people began exploring the forests looking for *Ganoderma lucidum*. These mushrooms were then sold in China. In Vietnam today, many newspapers speak of the current fever for collecting the ancient lingzhi<sup>22</sup>. Many people go in the deepest forests, and even into the forests of neighboring countries like Laos and Cambodia to look for this mushroom. In the province of Lam Dong it was reported that a thousand people were going into the forest everyday to look for the mushrooms.

It is claimed that the largest *Ganoderma* mushroom found in the world was harvested in Vietnam, and had a diameter of 110cm, a thickness of 33cm, and weighed 42kg. All ancient lingzhi mushroom collectors in the



Figure 2. Wild *Schizophyllum commune*



Figure 3. Northern Vietnam ethnic people selling and buying *Schizophyllum commune* in market in Lao Cai Province



Figure 4. Wild edible *Cantharellus luteocomus*, sold in market in Quang Ninh Province

<sup>15</sup> Vnn: Khoai lang

<sup>16</sup> Vnn: La lot

<sup>17</sup> *Macrobrachium nipponense*, Vnn: Con tom

<sup>18</sup> Vnn: Nam cheo

<sup>19</sup> Vnn: Cay cheo

<sup>20</sup> Vnn: Nam thong grows

<sup>21</sup> *Schizophyllum commune* Vnn: Nam chan chim

<sup>22</sup> *Ganoderma applanatum*, Vnn: Nam co linh chi

mountain forests of Vietnam should be careful not to destroy the source of the precious medical materials of Vietnam, many of which are still unknown.

Due to the active business of treating incurable illnesses with the ancient lingzhi mushroom, In July of 2003 the Vietnam government created within the Ministry of Health a special research facility devoted to the ancient lingzhi mushroom. Special attention is being paid to research on the treatment of illness and to the methods that can be employed to maintain the genetic security of this mushroom. Among the wild mushroom species of Vietnam mentioned above, several species have been cultured, such as the straw mushroom, wood ear mushroom, shiitake, and *Ganoderma* mushroom. But the majority of the cultivated species in Vietnam are actually introduced varieties that were not isolated from a source in Vietnam. There is hope that in the future biologists of Vietnam will be able to isolate and cultivate wild mushrooms from Vietnam in order that these species might provide appropriate cultivation species.